

1	2	3	4
POS	CODE/MODEL NO.	PART NAME	CATEGORY
A 1		INLET WITH COVER	PLASTIC
A 2		FRONT COVER (TOP)	PLASTIC
A 3		ROCKER SWITCH	ELECTRICAL
A 4		INDICATING LIGHT	ELECTRICAL
A 5		LID FOR WATER TANK	PLASTIC
A 6		WATER TANK	PLASTIC
A 7		SPRINKLER	MIXED
A 8		FUNNEL	PLASTIC
B 9		MAIN HOUSING	SUS 304
B 10		LID FOR THERMAL FLASK	PLASTIC
B 11		THERMAL FLASK	MIXED
B 12		FRONT COVER (BOTTOM)	PLASTIC
B 13			
B 14			
B 15			
C 16		WIRE TERMINALS	PLASTIC
C 17		ANTI-SLIP FEET	PLASTIC
C 18		INSULATION BOARD	GLASS FIBRE
C 19		TUBE - DRAIN	SILICONE
C 20		BOTTOM HOUSING	SUS 304
C 21		DRAINER	PLASTIC
C 22		CAP FOR DRAINER	PLASTIC
C 23		CABLE	ELECTRICAL
D 24		BACK COVER	SUS 304
D 25		TUBE - OVERFLOW	SILICONE
D 26		TUBE - OUTPUT	SILICONE
D 27		MICA HEATER B	ELECTRICAL
D 28		TOP HOUSING	SUS 304
D 29		MANUAL-RESET T/S	ELECTRICAL
D 30		RESET BOTTON	MIXED
D 31		FLOAT SENSOR	ELECTRICAL
D 32		SEAL FOR FLOAT SENSOR	SILICONE
D 33		SCREW NUT FOR FLOAT SENSOR	HARDWARE
D 34		BOILER	ELECTRICAL
E 35		TUBE - INPUT	SILICONE
E 36		PRESSURE SWITCH	ELECTRICAL

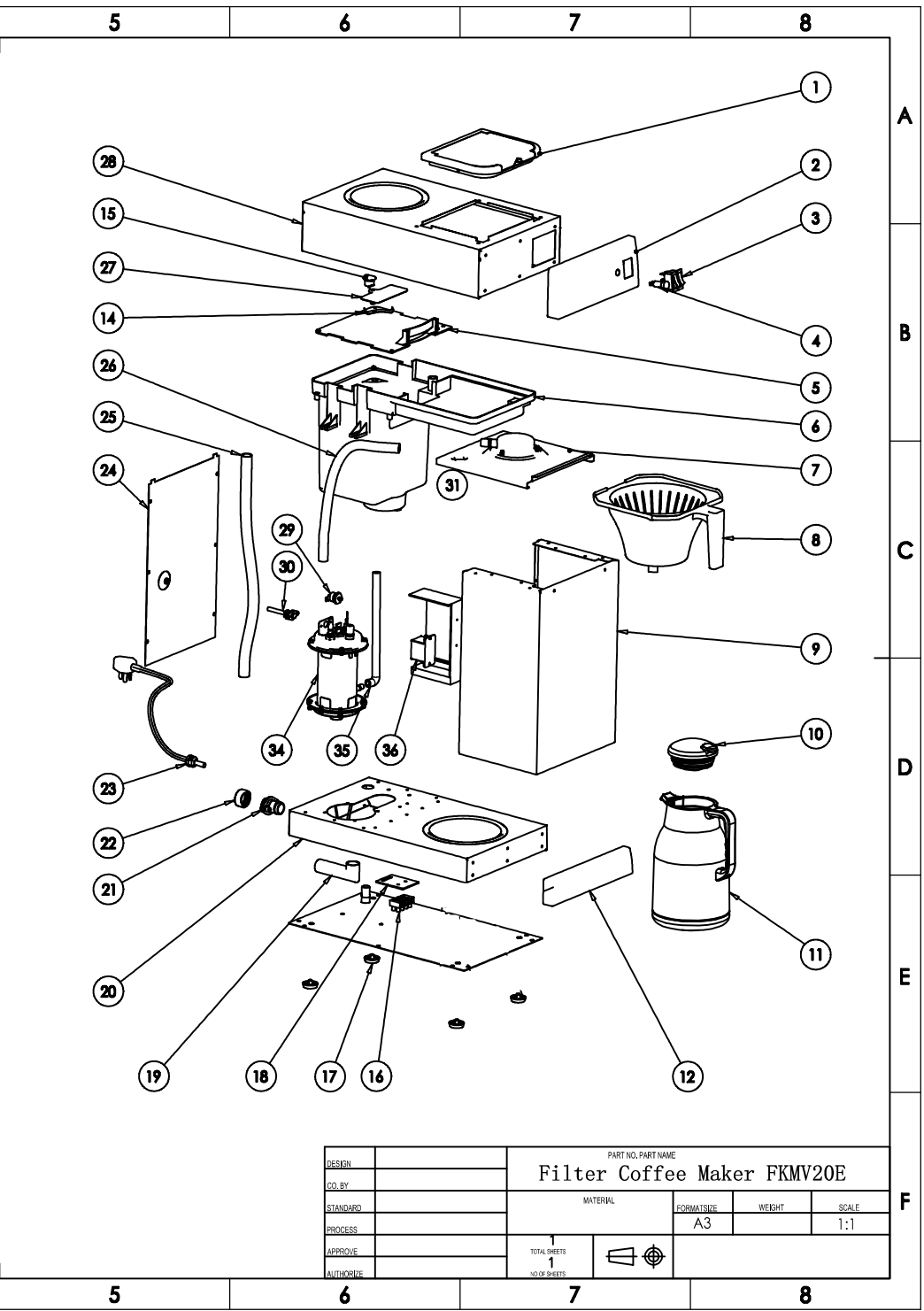

DESIGN	PART NO. PART NAME			
CO. BY	Filter Coffee Maker FKMV20E			
STANDARD	MATERIAL	FORMAT SIZE	WEIGHT	SCALE
PROCESS		A3		1:1
APPROVE	TOTAL SHEETS			
AUTHORIZE	1			