

# SHAKING MACHINE

MSMEB2/MSMEE2

## USER'S MANUAL



---

(Please read the introduction before using it)

## 1)NOTES:

A)Fix the machine on a smooth and stable place before using  
B)Please do not try to adjust the pressure plate when machine running. Put down the cup before machine working and take it out after working. Ensure all operation proceed when machine shut down.

C)The machine must be connected with the grounding wire tightly to ensure security; and should be equipped with leakage protection switch.

## 2)Basic parameter

Model	MSMEB2/MSMEE2
Dimension	400×300×392mm
Volts	220V
Power	40W
Speed	250 R/Minutes
Weight	28KGS

### 3)Machine Chart

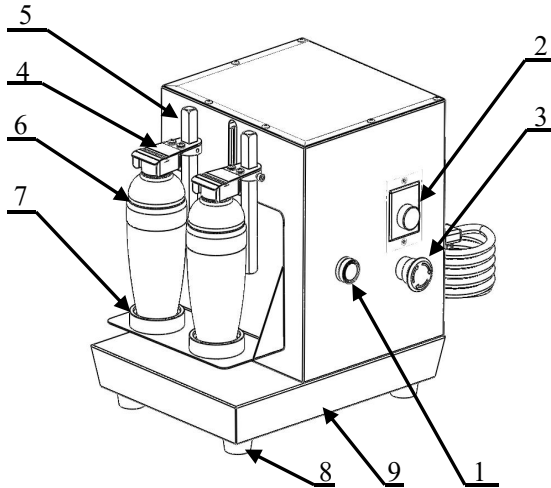

1. Start switch
2. Timer
3. Emergency stop switch
4. Bottle Top Press sheet
5. guide rod
6. Shaking bottle
7. Bottle bottom Press sheet
8. Machine rubber feet
9. Machine base

Attention: 40mm caliber shaking bottle is recommend.

## 4) Operation

A) Machine connect the power, turn on the timer, adjustable timer with 0~30 seconds (Remark: Milk tea shaking needs about 10 ~ 20 seconds); please set the speed button in maximum to prevent the machine cannot start.

B) Put the shaker bottle into the machine base, the shaker bottle top cover stuck in position, fix the bottle, tighten the screws on the side of the lower compression lever, the shaker bottle can be firmly fixed.

C) When everything has been adjusted finished, the operator leaves the machine within safety position. Presses the start switch, adjusts the speed as required and the shaker starts to work until it stops after the set time. Turn off the machine and take out the shaker bottle.

D) If you need to stop the machine urgently after starting due to unexpected factors, you can press the emergency stop switch.