

GHGK210 / GHGK315 / GHGK420 / GHGK525 / GHGK630

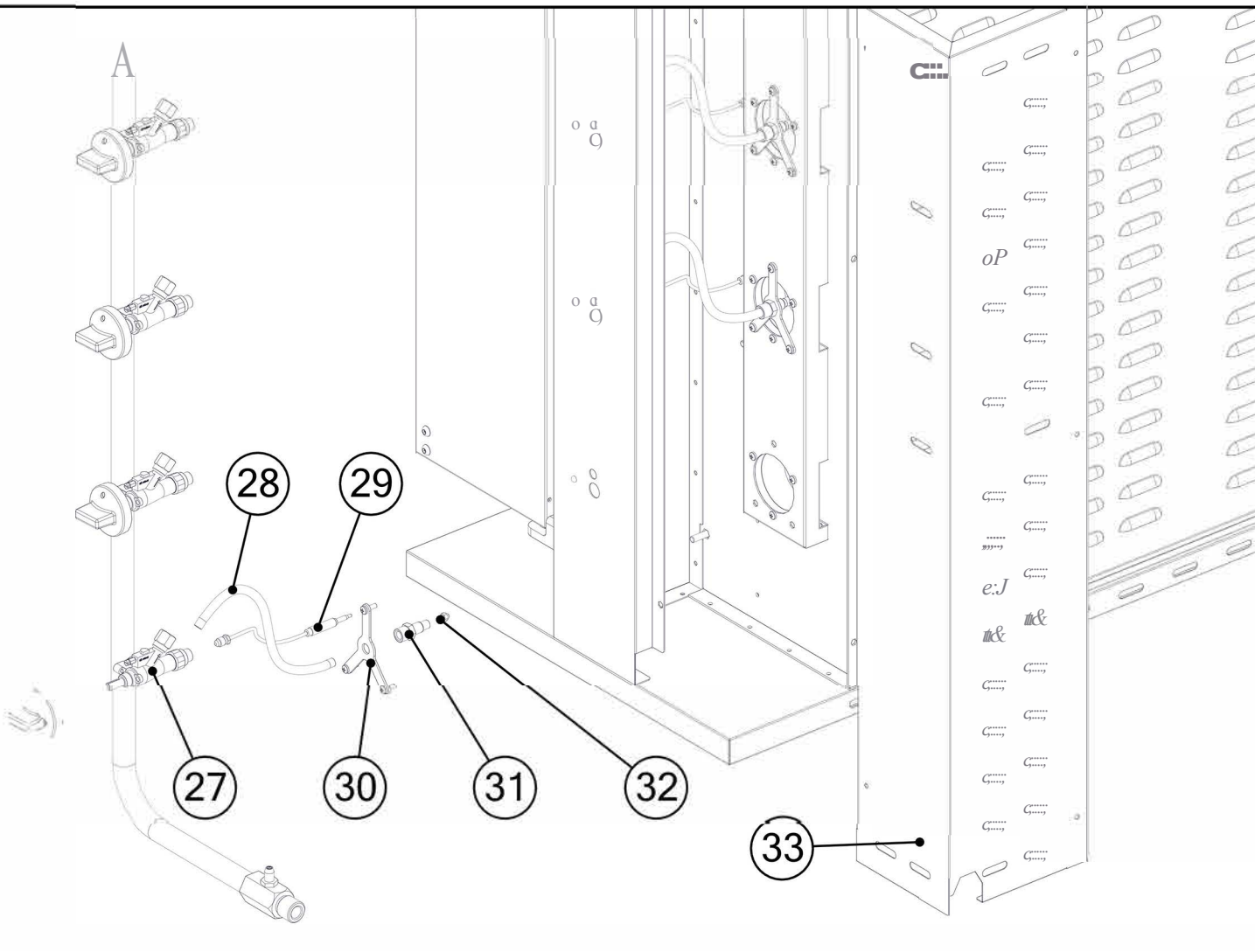
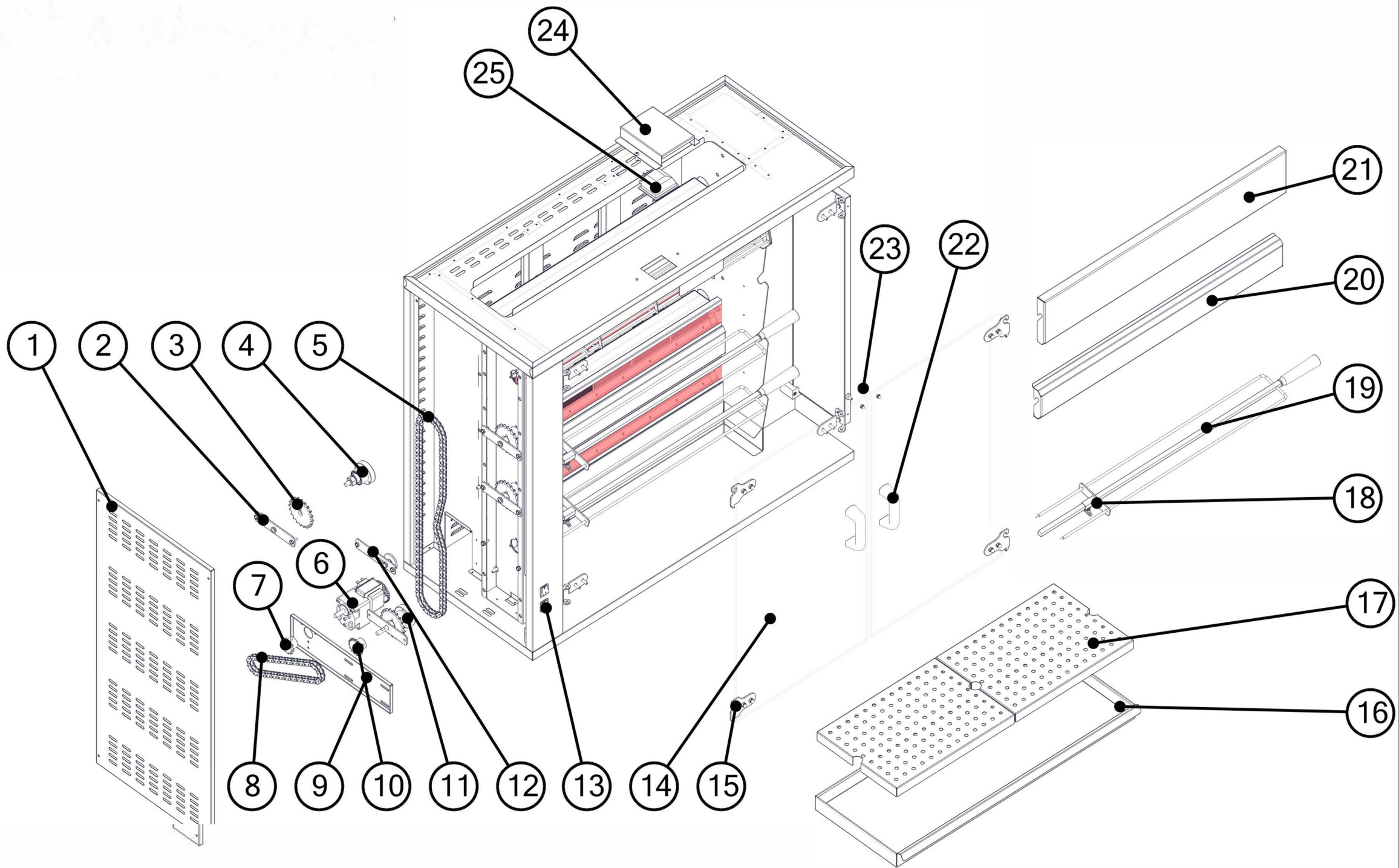

GHGK210 / GHGK315 / GHGK420 / GHGK525 / GHGK630

ITEM NO	PARTNAME	NUMBER
1	SiDE COVER LEFT	1
2	GEARHOLDER	5
3	GEAR	4
4	BEARING	3
5	CHAIN BiG	1
6	MOTOR	1
7	MOTOR GEAR 1/2' Z=1 0	1
8	CHAIN SMALL	1
9	MOTOR HOLDER PLATE	1
10	MOTOR GEAR 1/2' Z=15	1
11	BEARING MOTOR	1
12	CHAIN CLAMPING RiNG	1
13	ON/ OFF BUTTOn (MOTOR/BULB)	2
14	GLASSDOOR	2
15	GLASS DOOR HINGE	4
16	TRAY	1
17	STRAINER	2
18	SKEWER CLIPPER	4
19	SKEWER	4
20	BURNER PANNEL SMALL	3
21	BURNER PANNEL BiG	1
22	DOORHOLDER	2
23	MAGNET	2
24	BULBCOVER	1
25	BULB	1
26	ON/ OFF BUTTOn (BURNER)	4
27	GASVALVE	4
28	GAS PiPE	4
29	THERMOCOUPLE	4
30	NOZZLE HOLDER PROFILE	4
31	NOZZLE HOLDER	4
32	INJECTOR	4
33	SiDE COVER RiGHT	1