

FWS90

tritacarne/impastatrice meat grinders/meat mixers

- Costruzione in acciaio inox AISI 304 lavabile con spruzzo d'acqua.
- 2 motori indipendenti IP x5 per tritacarne e convogliatore:
 - Hp 1.5 per pala mescolatore/convogliatore
 - Hp 5 o Hp 7 per tritacarne 42
 - Hp 4 per tritacarne 32
- Riduttori angolari ermetici a bagno d'olio
- Micro di sicurezza su coperchio vasca
- Auto-apertura coperchio gestita da pistoni ad aria
- Comandi in acciaio inox IP 67 con inversione di marcia su TC

Gruppo macinazione:

- Completamente in acciaio inox AISI 304
- Studiato per grandi prestazioni
- Perno trascinatore in acciaio inox
- Perno elica in acciaio temperato
- Smontaggio rapido bocca e pala senza l'uso di attrezzi
- **Esclusivo sistema brevettato di controllo presenza piastra e coltello.**

- *AISI 304 stainless steel construction, can be sprayed.*
- *2 independent IP x5 motors for grinder and mixer:*
 - *5 Hp or 7Hp meat grinder motors (42 model)*
 - *5 Hp or 7Hp meat grinder motors (42 model)*
 - *4 Hp meat grinder motor (32 model)*
- *Oil-bath, waterproof angular gear box*
- *Safety microswitch on meat mixer cover*
- *Air pistons open the cover*
- *IP 67 stainless steel controls (reverse available for grinder)*

Grinding set:

- *Completely made of AISI 304 stainless steel*
- *Designed for high performance*
- *Stainless steel drive pin.*
- *Tempered steel worm pin.*
- *Grinding set and mixing arm can be easily disassembled without tools*
- ***Exclusive, patented plate and knife detection system.***

Dotazione

standard:

- Coltello e piastra diam. 4,5 autoaffilanti inox
- Struttura autoportante con ruote inox con freno
- Attrezzo estrazione elica e piastre.
- Leva fissaggio ghiera

Standard accessories:

- *Stainless steel self-sharpening knife and 4,5 mm plate*
- *Floor support with stainless steel wheels and brake*
- *Worm and plate removing tool*
- *Ring fixing/removing tool*

Coperchio con sollevamento automatico

Lid with self lifting





Opzionale: sistema di protezione interbloccato per uso piastre con foro > 8 mm

Optional: interlock protection for more than 8 mm holes plates.

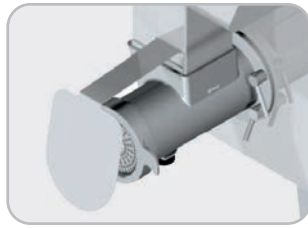

Opzionale: paraspruzzi
Optional: splash guard



Pedaliera opzionale
Optional pedal controls



Sistema comandi Full Control (per Format S/SX)
Full Control system (for Format S/SX)



Leva avvita/svita ghiera TC 32 standard
Standard TC 32 ring fixing/removing tool



Leva avvita/svita ghiera TC 42 standard
Standard TC42 ring fixing/removing tool



Estrattore piastre
Plates removal tool

Comandi FULL CONTROL con:

Funzionamento temporizzato
Inversione di marcia temporizzata su pala mescolatore
Possibilità di collegamento accessori quali:

- pedaliera
- hamburgratrice semiautomatica Format S e SX

Optional disponibili:

- Paraspruzzi inox
- Protezione bocca interbloccata per piastre con foro > 8 mm
- Bocca unger parziale o totale inox
- SRCS Scheda di controllo remoto

FULL CONTROL:

Timer function
Reverse with timer for meat mixer
Optional connections for:

- pedal controls
- Format S and SX semi-automatic hamburger press attachment

Optional available:

- Stainless steel splash guard
- mouth guard interlocked for plates with 8 > mm
- Stainless steel 1/2 or total unger grinding set
- SRCS wifi control board



FWS90
gambe alte opzionali
optional high legs X:
333 mm
Y: 717 mm
Z: 1575 mm

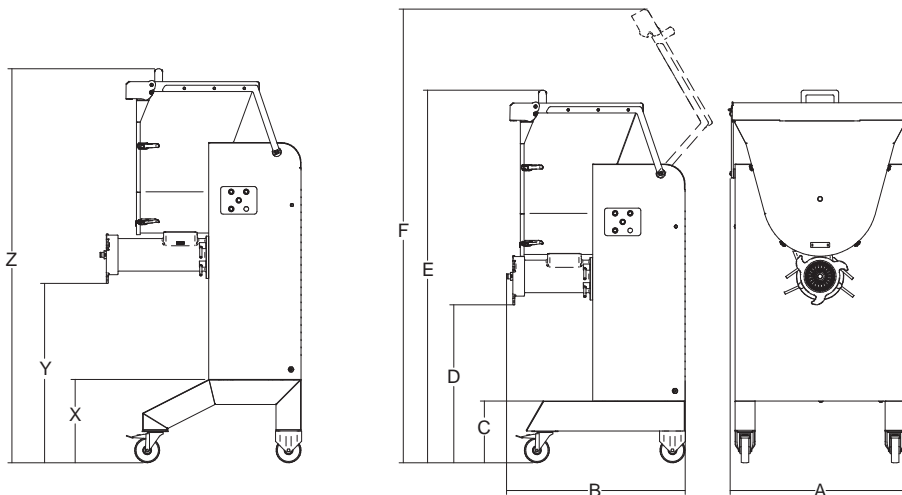

	watt/Hp	watt/Hp	kg/lt	ø mm	r.p.m.	kg/h.	mm	mm	mm	mm	mm	mm	kg	mm	kg	
FWS90	5145/7	1102/1.5	1ph/3ph	90-120	4.5	TC186/ IP30	1000-1200	746	805	247	631	1489	1813	191	870x840x1700	216