

# Exploded view CUH6 & CUH9

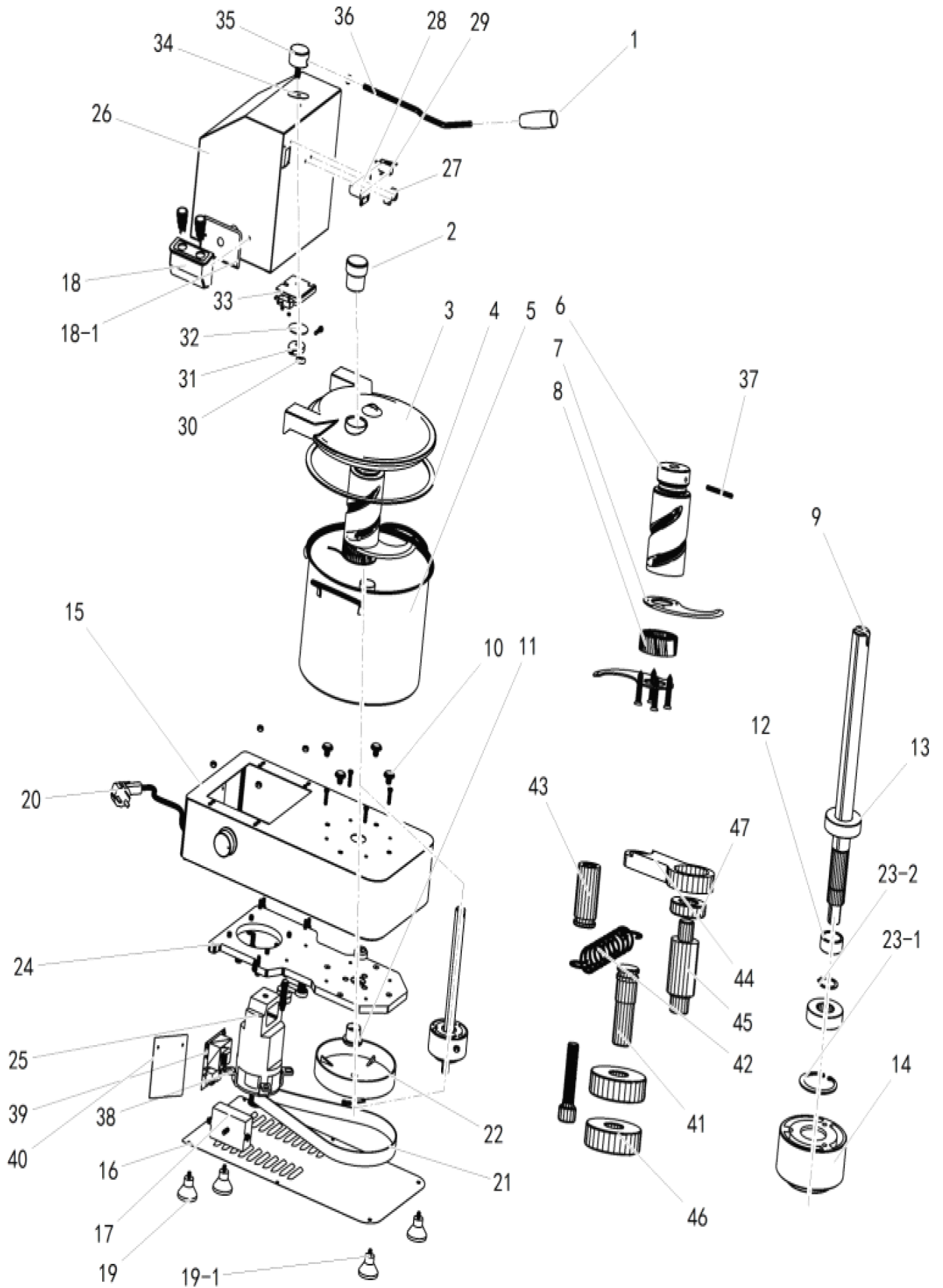

No	Description
1	Handle
2	Chuck plug
3	PC cover
4	Water-proof gasket
5	container
6	Up tool apron
7	Rotate knives
8	Down tool apron
10	Rubber gasket
11	Locating sleeve
9	Blade shaft
12	Spacer bush
13	Bearing
14	Blade shaft
23-1	Internal circlips Ø42
23-2	Bearing circlips
15	Base seat component
16	Base board
17	Knob
18	Switch box Seal bar
18-1	gasket for electric box
19	Feet Rubber feet
20	Power cable
21	Belt
22	Big belt pulley
24	Main board
25	Motor
26	Welding
27	Limited block
28	Front switch holder
29	Sure model switch
30	Big nut
31	Cam
32	Big gasket
33	Up switch holder
34	Nylon gasket
35	Handle seat
36	Compression bar
37	Dowel
38	Motor holder
39	Circuit board
40	Installation board
41	Tension wheel shaft
42	Tension spring
43	Small shaft
44	Tension wheel arm
45	Wheel shaft 2
46	Bearing 6200
47	Bearing 6800