

BGSF
AUFRECHTE KÜHLUNG
MATERIAL UND TECHNISCHE DATEN
MATERIAL AND TECHNICAL CHARACTERISTICS MANUEL

INHALT / INDEX :

- 1. EIGENSCHAFTEN / CHARACTERISTICS**
- 2. INNEN- UND AUSSENMASSE/ INSIDE , OUTSIDE DIMENSIONS**
- 3. EXPLOSIONSBILDER / EXPLODED WIEV**
- 4. ERSATZTEILLISTE / SPARE PART LIST**
- 5. GAS- UND STROMREGELUNG / GAS AND ELECTRICAL SCHEME**

BGSF AUFRECHTE KÜHLUNG

MATERIAL UND TECHNISCHE DATEN



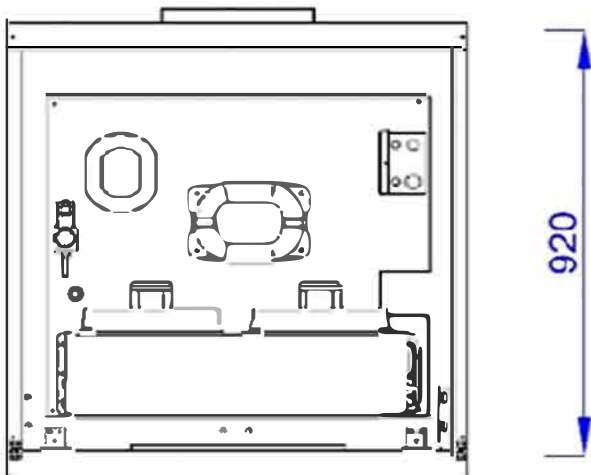
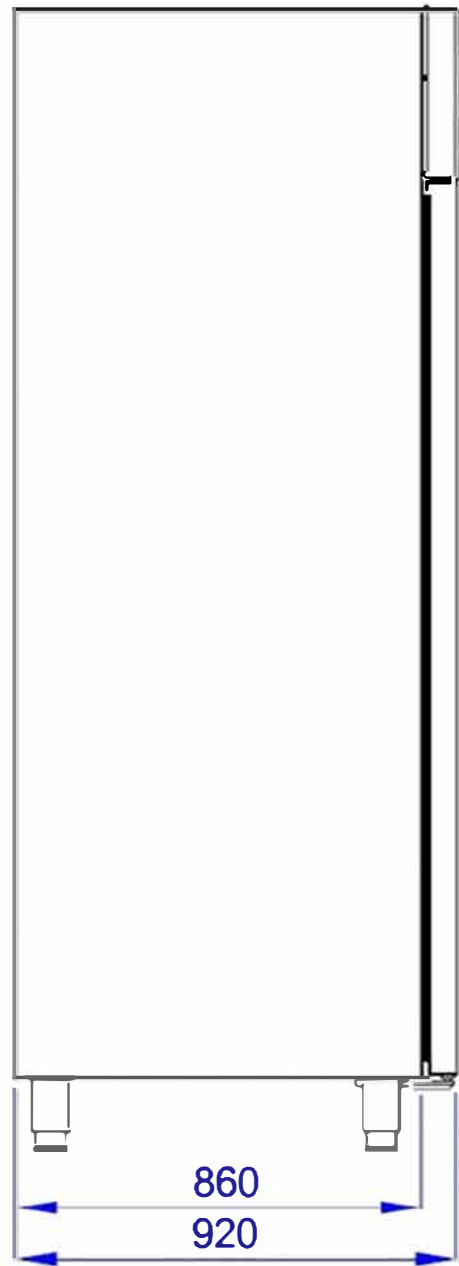
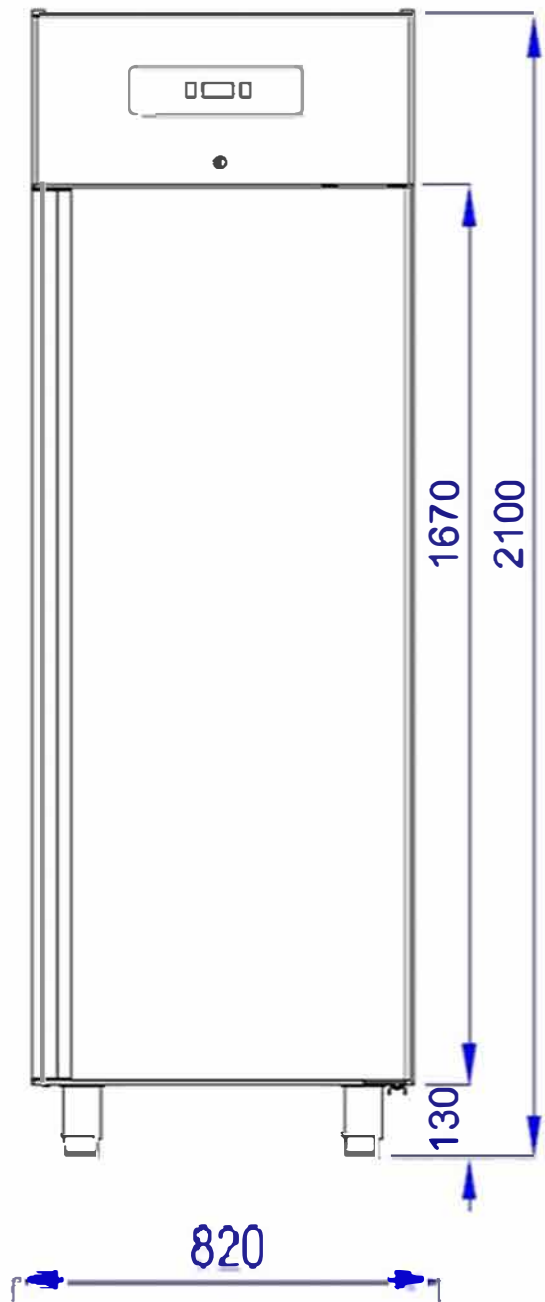

AUSSENMASSE / OUTSIDE DIMENSIONS = 820x920x2100
INNENMASSE / INSIDE DIMENSIONS = 700x800x1565

**BGSF CHARAKTERISTISCHE MERKMALE /
BGSF CHARACTERISTIC SPECIALITIES**

Sicherheitsklasse / Safety Class	:1
Betriebstemperatur / Working Temperature C	:-10 / -30C
Thermostat Einstelltemperatur / Thermostate Set Temperature	:-20 C
Umgebungstemperatur/ Environment Temperature	:+43C
Luftfeuchtigkeit/ Environment Moisture Propertion	:%65
Energieverbrauch / Energy Consuption	:0,30 KW/h
Strom / Power	:0,60 KW
Spannung - Frequenz / Voltage- Frekans	:230V / 50 Hz

ZUBEHÖR UND KONTROLLLEUCHTEN / ACCESORIES AND CONTROL SWITCHES

Digitaler Thermostat / Digital Thermometer	: Digitaler Thermometer
Energie Lampe / Energy Lamp	: Ad / PCC1
Ein/Aus Schalter / Power Switch	: Ad / PCS1
Scharnier Gruppe / Hinges Group	: Ad / PCS1
Stand / Stand	: Ad/PCS 4 Rostfreier Fuß / + stainlies Steel

TECHNISCHE DATEN/ TECHNICAL CHARACTERISTICS

Äußere Abmessungen / Outside Dimensions	: 820x920x2100mm
Innere Abmessungen / Inside Dimensions	: 700x800x1565mm
Abmessungen der Verpackung / Package Dimensions	: 900x1000x2230mm
Innen Volumen / Inside Volume	: 850 lt
Brutto Gewicht / Gross Weight	: 176 kg
Netto Gewicht / Net Weigt	: 150 kg
Äußerer Körper / Outside Body	: 0,60 mm INOX 430 SB+PVC
Innenkörper/ Inside Body	: 0,50 mm INOX 430 MAT+PVC
Isolierung Metarial Dicke /Insulation Metarial Thicnes	: 60 mm
Isolierung Metarialvolumen / Insulation Metarial Volume	: 42 Kg / m3 +/-1
Kompressor / Compresor	:Embraco NJ2212 R404A
Kondanser / Condanser	: 2HP Kondenser
Kondensator-Lüfter/ Condanser Fan	: 16/65W--0,45A--1300/1550 Rpm--230V
Verdampfer / Evaporatör	: SHP19 Evaporator
Trockner / Dryer	: 30 gr 15002SGDR02 Doppelter Eingang
Kühlschrank Gas / refrigerator Gas	: R404A
Art. Gas Menge/ Ref. Gas Quantity	920 gr
Zertifizierungen / Certifications	: Entspricht der TS 2225 EN 30335-2-4.
Seriennummer / Serial No	: Vollgepackt und leicht zu lesen / Packed And Easy Read
Verpackung/ Packing	: Hölzerne Palette Ist unten und bedeckt / Wooden Palet Is Down And Covered

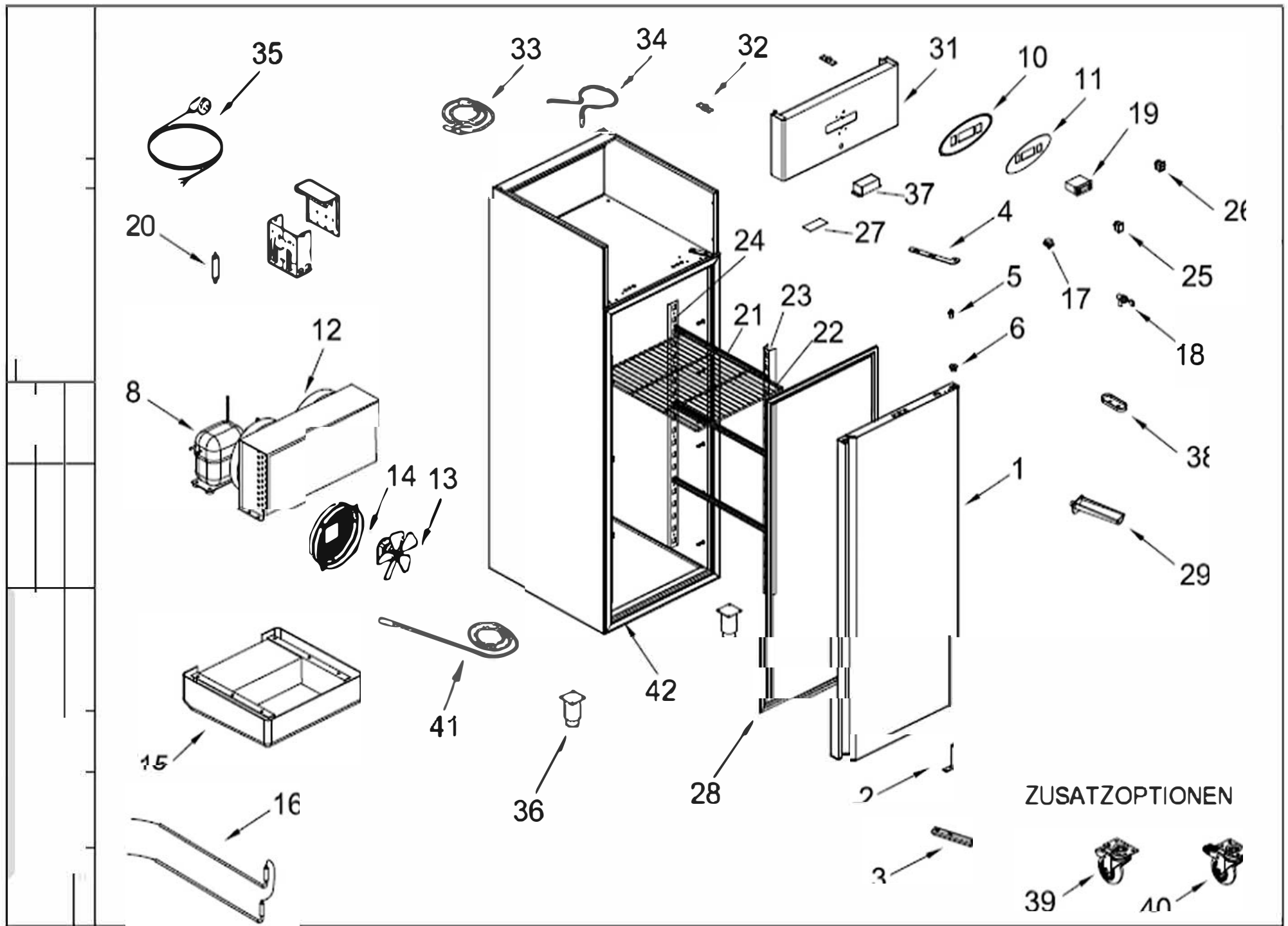

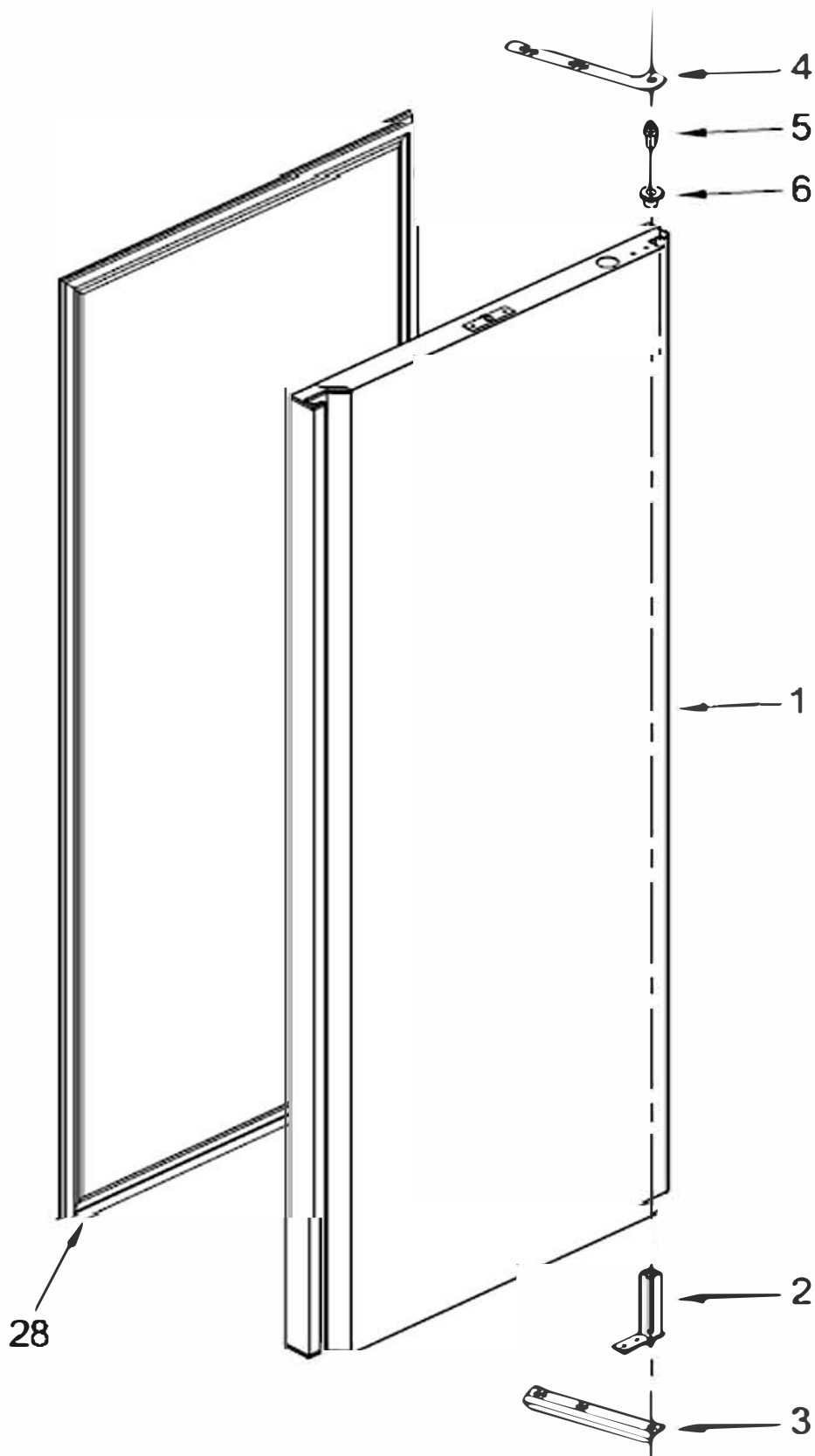

VERTIKALE KÜHLSCHRÄNKE - TÜRAUSWAHL

BGSF ERSATZTEIL LISTE /BGSF SPARE PART LIST

NR		TEIL NAME	MATERIAL NAME	STK
1	01A01KA176	TÜR	DOOR	1
2	B02ME100	AUFRECHTES SCHARNIER UND TEILE	UPRIGHT HINGE AND PARTS	1
3	P30090008	ANHÄNGER SCHARNIERBÜGEL	LOVER HINGE BRACET	1
4	P30090007	OBERE SCHARNIERSTREBE	UPPER HINGE BRACET	1
5	B02ME101	OBERES SCHARNIER PIM	UPPER HINGE PIM	1
6	B02ME102	OBERES SCHARNIER KUNSTSTOFFTEIL	UPPER HINGE PLASTIC PART	1
8	A00KO103	KOMPRESSOR	COMPRESSOR	1
10	A00DJ107	KUNSTSTOFFABDECKUNG	PLASTIK COVER	1
11	A00DJ105	DIGITALES ETIKETT	DIGITAL LABEL	1
12	A00KN103	KONDANSER - 2 HP	CONDANSER - 2 HP	1
13	A00FA104	16W-LÜFTERMOTOR	16W-FAN MOTOR	1
14	A00EP101	KONDANSER VENTILATOR KUNSTSTOFF	CONDANSER FAN PLASTIC	1
15	A00SHP019	VERDAMPFER (MIT VENTILATOR)	EVAPARATOR (FAN INCLUDED)	1
	B00PK100-19	VERDAMPFERSCHRANK KUNSTSTOFF	EVAP KABINET PLASTIC	1
16	B00REZ139	VERDAMPFERHEIZUNG FÜR SHP19	EVAPORATOR HEATER FOR SHP19	2
17	B00DU103	VERDAMPFERSCHALTER	EVAPORATOR SWITCH	1
18	B00KI100	SCHLOSS	LOCK	1
19	A00DJ156	EVCO DIGITAL	EVCO DIGITAL	1
20	A00DR100	DRAYER	DRAYER	1
21	P10406080-D	REGALFÜHRER - EISCREME	SHELF GUIDE - ICECREAM	6
22	B01RF130	REGAL - EISKREM	SHELF - ICECREAM	3
23	P11070027-D	VORDERER REGALSCHALTER	FRONT SHELF RACKET	2
24	P11070026-D	REGALSCHIENE	BACK SHELF RACKET	2
25	B00DU101	NETZSCHALTER	POWER SWITCH	1
26	B00DU102	EIN - AUS SCHALTER	ON - OFF SWITCH	1
27	B00LA107	LEUCHTGLASAUFSTAND	LIGHT GLASS UPRIGHT	1
28	A00CO135	TÜRDICHTUNG FÜR SPEISEEIS	DOOR GASKET FOR ICECREAM REF	1
29	B00BH103	WASSERVERTEILANLAGE	WATER DISPENSING UNIT	1
31	C16070033	Vordach	CANOPY	1
32	B01ME111	KANUFFENHÄNGE	CANOPY HINGE	2
33	A00DJ109	PROGRAMM - 3mt	PROP	1
34	A00DJ102	PROGRAMM - 1,5mt	PROP	1
35	B00FK100	STECKERKABEL	PLUG CABLE	1
36	B00AY100	BEIN AUS ROSTFREIEM STAHL	STAINLESS STEEL LEG	4
37	G4480055	LICHTABDECKUNG	LIGHT COVER	1
38	B00TK100	PROP DECKEL	PROP COVER	1
39	B00AY101	RÄDER	WHEELS	2
40	B00AY102	RÄDER BREMSE	WHEELS BRAKE	2
41	B00REZ103	DRENAJ WIDERSTAND 2+1	DRENAJ RESISTANCE 2+1	1
42	B00REZ102	TÜRWIDERSTAND 4,7mt	DOOR RESISTANCE 4,7mt	1

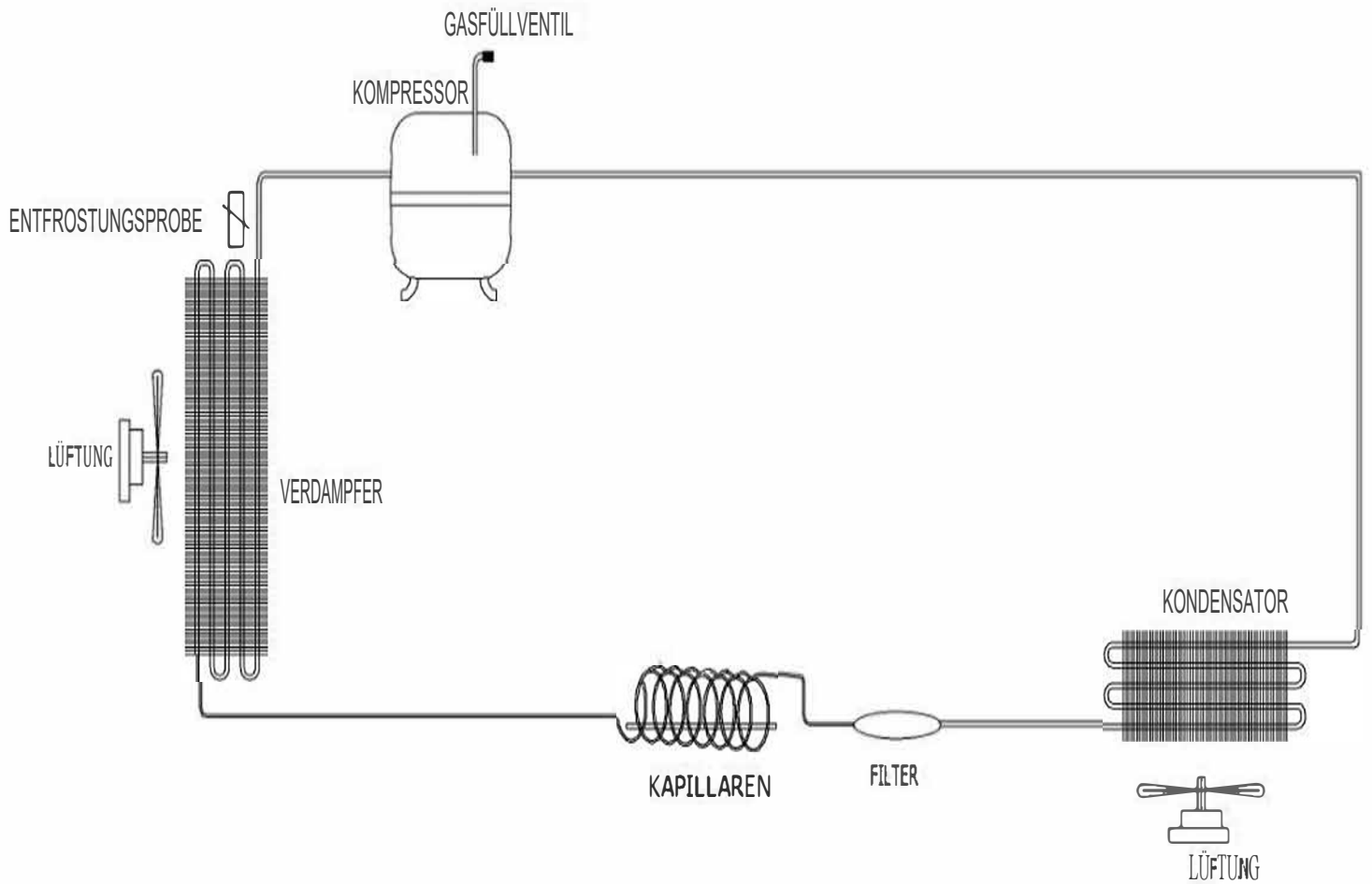

VL 15-BL 15 TIEFKÜHLTRUHE MONOBLOCK ELEKTRISCHES SCHEMA
 VL15-BL15 DEEP FREEZE MONO-BLOCKELECTRICAL SCHEMA

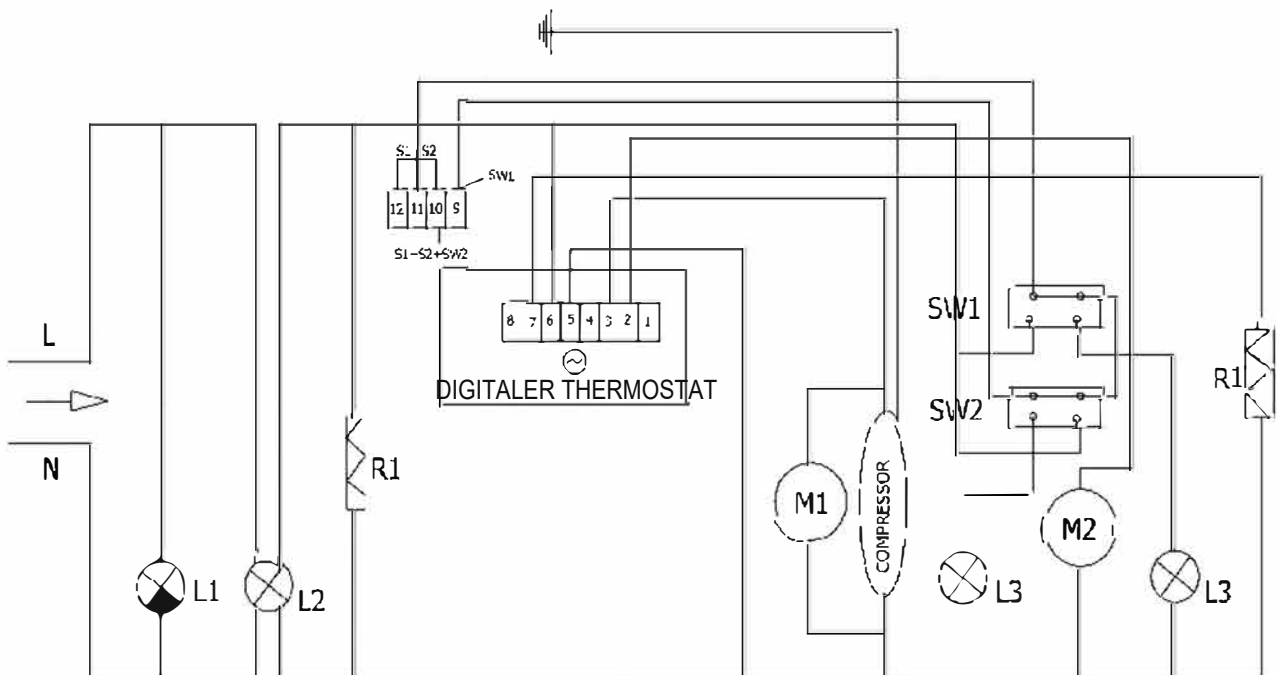

SW1-SW2: EIN/AUS-SCHALTER
 S 1-S2: SENSOR
 XR 60 °C : DIGITALES THERMOMETER
 M1 : GEBLÄSEMOTOR
 M2 : MOTOR DES VERDAMPFERLÜFTERS

L1 : ANZEIGE-LICHT
 L2 : EIN/AUS LIGHT
 L3 : KANOPI-LICHT
 T: O-90 THERMOSTAT
 RI: TÜR WIDERSTAND / DOOR RESISTANCE
 R: RESISTENZ