

BKSF1700
TECHNISCHES HANDBUCH
TECHNICAL MANUAL

INHALTSVERZEICHNIS / INDEX :

- 1. MERKMALE / CHARACTERISTICS**
- 2. INNEN- UND AUSSENMAßE/ INSIDE , OUTSIDE DIMENSIONS**
- 3. EXPLOSIONSZEICHUNG / EXPLODED VIEW**
- 4. ERSATZTEILLISTE/ SPARE PART LIST**
- 5. SCHALTPLAN / WIRING DIAGRAM**

BKSF1700



BESONDERE MERKMALE / CHARACTERISTIC SPECIALITIES

Klimaklasse / Climate class	:F
Sicherheitsklasse / Safety class	:1
Betriebstemperatur / Working temperature °C	:-2 / +10 °C
Thermostat-Solltemperatur / Thermostat set temperature	:+2 °C
Umgebungstemperatur / Ambient temperature	:+43 °C
Luftfeuchtigkeit / Humidity	:%65
Energieverbrauch / Energy consumption	:0,25 KW/h
Leistung / Power	:0,65 KW
Spannung - Frequenz / Voltage - Frequency	:220-240V / 50 Hz

ZUBEHÖR UND STEUERSCHALTER/ ACCESORIES AND CONTROL SWITCHES

Digitales Thermometer / Digital thermometer	:Digitales Thermometer /Digital thermometer
Power-Lampe / Power lamp	:Stk. / Pcs. 1
Netzschalter / Power switch	:Stk. / Pcs. 1
Scharniergruppe / Hinge group	:Stk. / Pcs. 4
Fuß / Feet	:Stk. / Pcs. 5

TECHNISCHE DATEN/ TECHNICAL CHARACTERISTICS

Außenmaße / Outside dimensions	:1720x1010x2130mm
Innenmaße / Inside dimensions	:1560x830x1350mm
Verpackungsmaße / Packing dimensions	:1800x1060x2280mm
Bruttogewicht / Gross weight	:300 kg
Nettogewicht / Net Weight	:280 kg
Außengehäuse / External housing	:0,60 mm INOX 430 SB+PVC
Innengehäuse / Internal housing	:0,50 mm INOX 430 MAT+PVC
Isolierungsmaterial / Insulation material	:Polyurethan / Polyurethane
Isolierung / Insulation	:80 mm
Isolierungsdichte / Insulation density	:42 Kg / m3 +/-1
Kompressor / Compressor	:NEU 6210 U R290 - 50Hz
Kondensator / Condenser	:1/2 Hp R290
Kondensator-Lüfter / Condenser fan	:10W
Verdampfer / Evaporator	:RHP22
Verdampfer-Lüfter / Evaporator Fan	:RHP22
Trockner / Dryer	:30 gr 15002SGDR02
Kältemittel /Refrigerant	:R290
Kältemittelmenge/ Refrigerant amount	:120 gram
Zertifizierungen / Certifications	:TS 2225 EN 30335-2-4
Seriennummer / Serial No	: Auf der Verpackung / On the packaging
Verpackung / Package	: Holzpalette , Verpackt in Karton und Nylon / Wooden pallet , Packed in carton and nylon

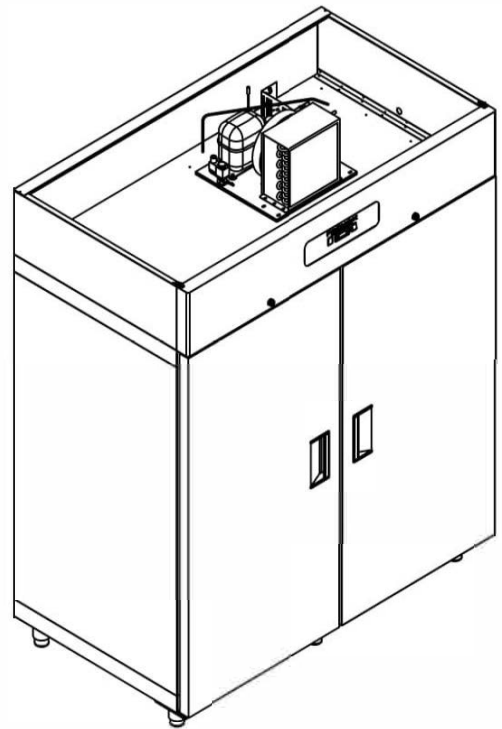
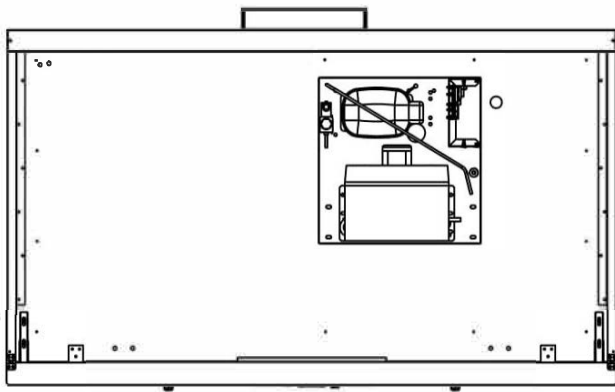
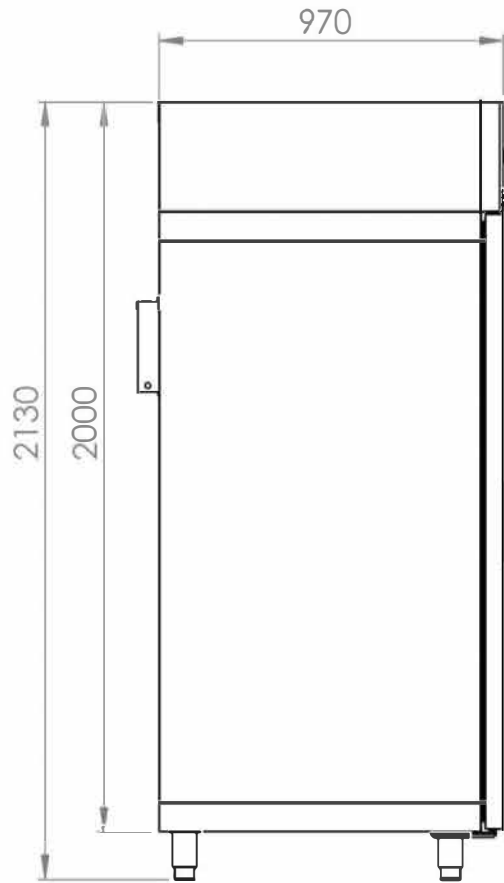
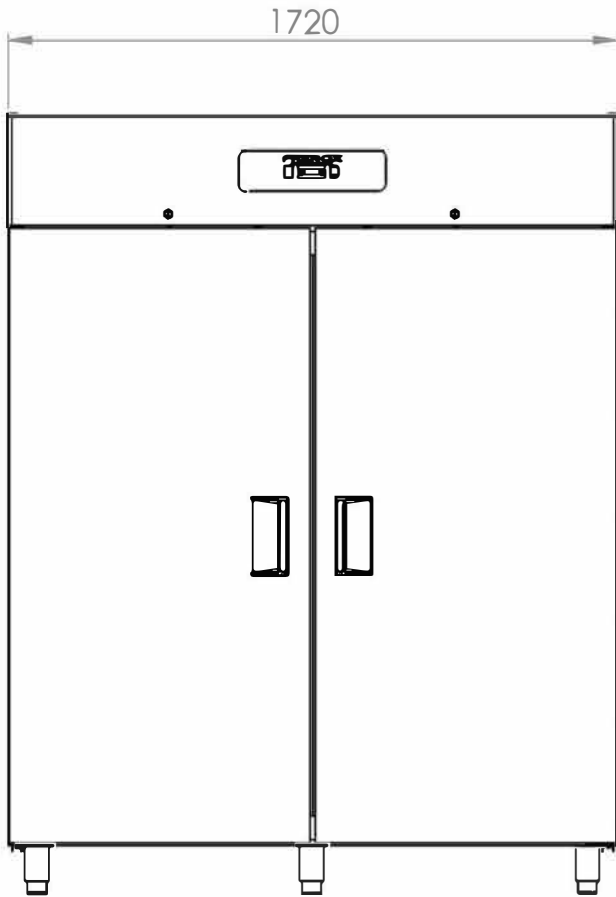

AUSSENMAßE/ OUTSIDE DIMENSIONS : 1720X970X2130

INNENMAßE/ INSIDE DIMENSIONS: 1560X830X1350

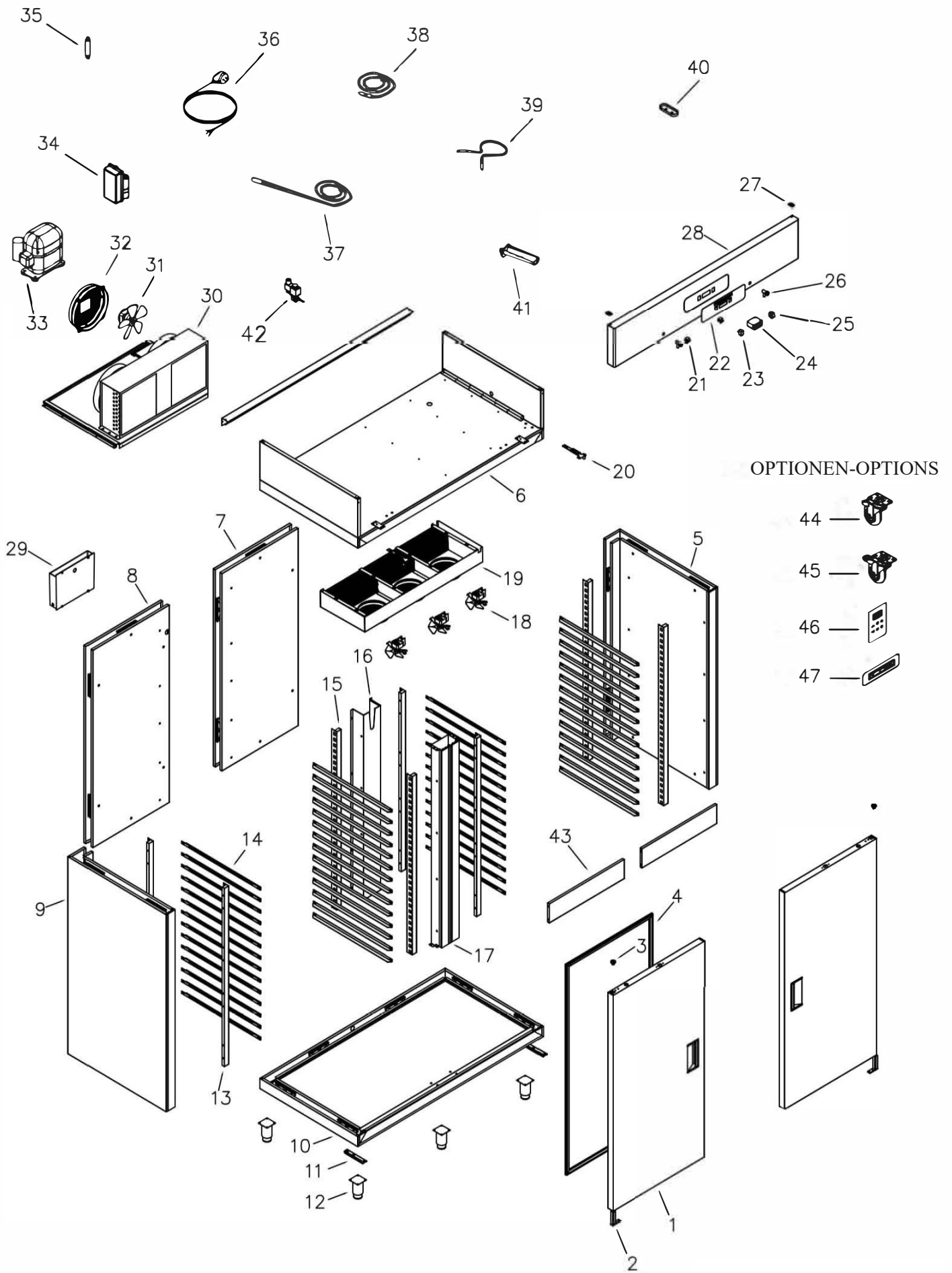

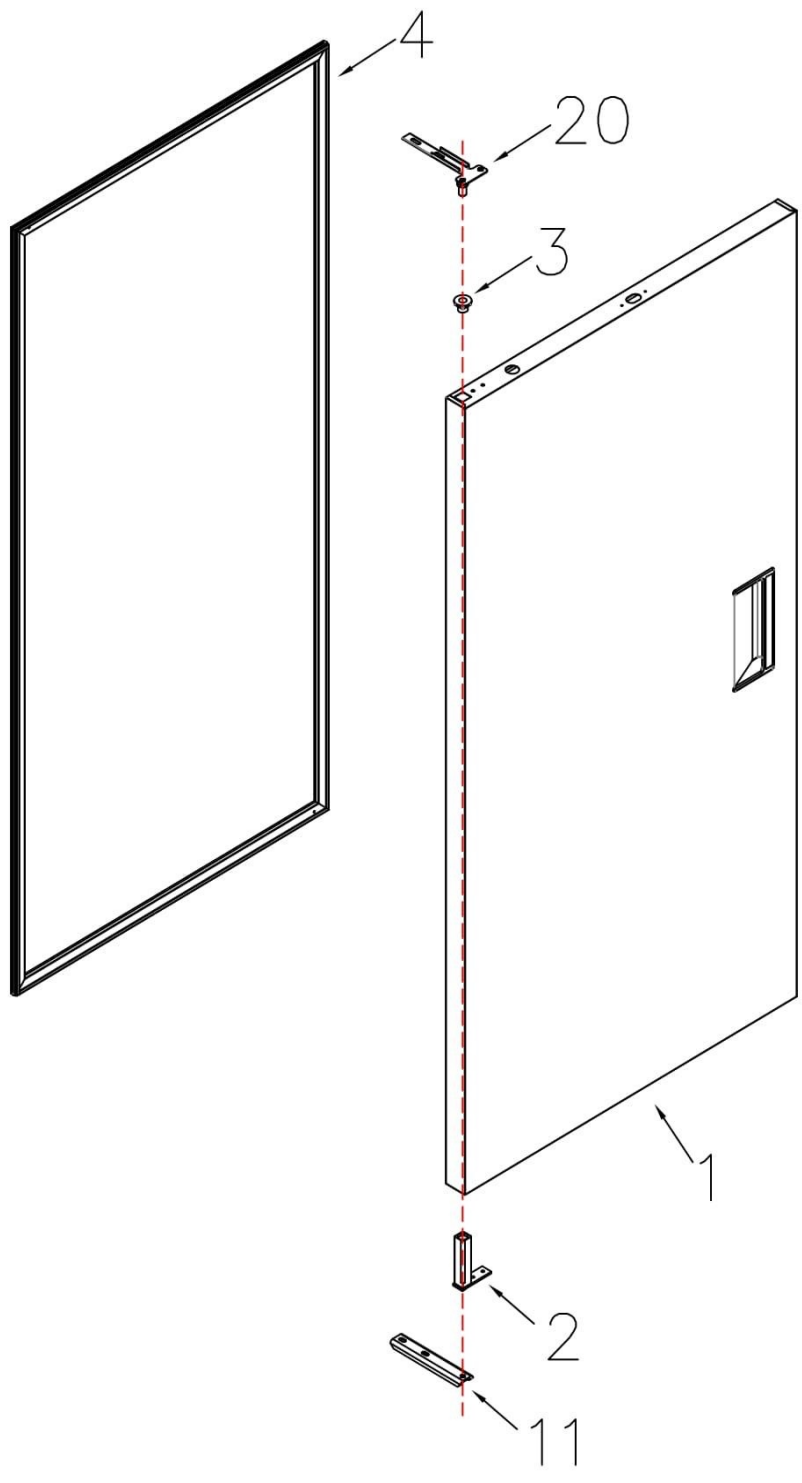

BKSF1700 ERSATZTEILLISTE / BKSF1700 SPARE PART LIST

NR.	CODE	BEZEICHNUNG	DESCRIPTION	ANZAHL QUANTITY
1	01A01KA259	TÜR	DOOR	2
2	B02ME100	SCHARNIER	HINGE	2
3	B02ME102	SCHARNIERBUCHSE	HINGE BUSHING	2
4	A00CO162	TÜRDICHTUNG	DOOR GASKET	2
5	01A01PA151-R	SEITENPLATTE	SIDE PANEL	1
6	01A01TV161	OBERE PLATTE	TOP PANEL	1
7	01A01PA706-R	HINTERE PLATTE	REAR PANEL	1
8	01A01PA706-L	HINTERE PLATTE	REAR PANEL	1
9	01A01PA151-L	SEITENPLATTE	SIDE PANEL	1
10	01A01TB161	UNTERE PLATTE	BOTTOM PANEL	1
11	P30090008	SCHARNIER	HINGE	2
12	B00AY101	EDELSTAHL FUSS	STAINLESS STEEL LEG	5
13	P10406083-L	STANGE	ROD	4
14	P10406080	REGALSCHIENE	RACK RAIL	56
15	P10406083-R	STANGE	ROD	4
16	P10016001	STANGE	ROD	1
17	P05016006	STANGE	ROD	1
18	A00RHP022-F	VERDAMPFER-LÜFTER	EVAPORATOR FAN	3
19	A00RHP022	VERDAMPFER	EVAPORATOR	1
20	P30090007	SCHARNIER	HINGE	2
21	B00DU103	TÜRSCHALTER	DOOR SWITCH	2
22	A00DJ112	BL16-P-ETIKETT	BL16-P LABEL	1
23	B00DU101	NETZSCHALTER	POWER SWITCH	1
24	B00DU102	EIN / AUS SCHALTER	ON - OFF SWITCH	1
25	A00DJ156	DIGITALER THERMOSTAT	DIGITAL THERMOSTAT	1
26	B00K1100	VERRIEGELUNG	LOCK	2
27	B01ME111	SCHARNIER	HINGE	2
28	C08016000	PLATTE	PANEL	1
29	B01BH108	WASSERVERDAMPFUNGSANLAGE	WATER VAPORAZATION UNIT	1
30	A00KN111	KONDENSATOR 1/2HP R290	CONDENSER 1/2HP R290	1
31	A00FA109	10W LÜFTER	10W FAN	1
32	A00EP101	LÜFTERABDECKUNG	FAN COVER	2
33	A00KO203	NEU 6210 U R290 - 50Hz	NEU 6210 U R290 - 50Hz	1
34	A00KO203-A	RELAIS-BOX	RELAY BOX	1
35	A00DR100	TROCKNER	DRAYER	1
36	B00FK100	NETZKABEL	PLUG CABLE	1
37	B00REZ103	ABFLUSSWIDERSTAND 2+1	DRAINAGE RESISTANCE 2+1	1
38	A00DJ109	SONDE	PROBE	1
39	A00DJ102	SONDE	PROBE	1
40	B00TK100	SONDENABDECKUNG	PROPE COVER	1
41	B00BH104	WASSERSPENDER	WATER DISPENSER	1
42	A00SL100	SELENOIDVENTIL 1/4	SELENOID VALVE 1/4	1
43	P06016007	VORDERES SPIEGELBLECH	FRONT MIRROR SHEET	2
44	B00REZ102	TÜR-WIDERSTAND 4,7mt	DOOR RESISTANCE 4,7mt	2
45	B00AY101	RAD - OHNE BREMSE	WHEEL WITHOUT BRAKE	3
46	B00AY102	RAD - MIT BREMSE	WHEEL WITH BRAKE	2
47	A00DJ139	WASSERDICHTES BEDIENFELD	WATERPROOF CONTROL PANEL	1
48	A00DJ120	TOUCH-BEDIENFELD	TOUCH CONTROL PANEL	1

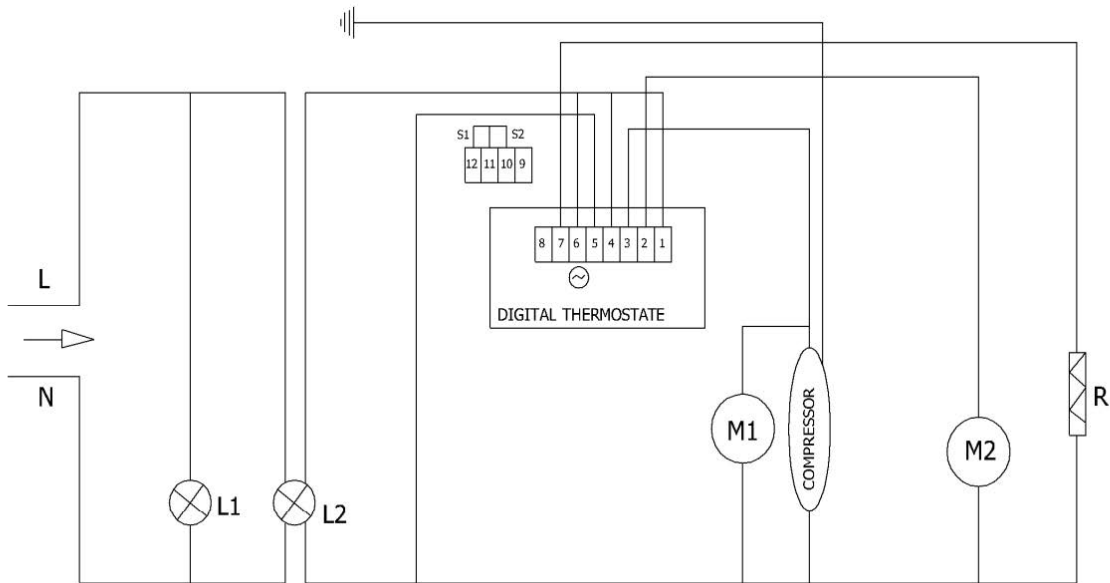

DIGITALER THERMOSTAT/ DIGITAL THERMOSTAT
M1 : LÜFTERMOTOR (KONDENSATOR) / FAN MOTOR (CONDENSER)
M2 : LÜFTERMOTOR (VERDAMPFER) / FAN MOTOR (VERDAMPFER)
S1 : SONDE / PROBE
S2 : SONDE / PROBE
L1 : POWER-LAMPE/ POWER LAMP
L2 : EIN / AUS LAMPE / ON OFF LIGHT
R: VERDAMPFUNGSWIDERSTAND / EVAPORATE RESISTANCE

