

COUNTER TYPE COOLER UNITS USE AND MAINTENANCE MANUAL





Dear Customer,

This product is manufactured in environmentally friendly modern facilities and has environmentally friendly technologies.

Asbestos, formaldehyde, cadmium and CFC free materials and PCB, PCT free compressor oil were used throughout the production period of the product. The gas used in your device is R134a, R404a, R290 and R600a. These gases comply with the KYOTO protocol.

The device is manufactured for industrial use and should not be used outside of its purpose. Our company is not responsible for any malfunctions arising from improper use and the product is not covered by the warranty.

It is entirely the responsibility of the consumer to take measures related to the food in the product in case of any malfunction in the product or due to usage error.

TABLE OF CONTENTS

1. GENERAL INFORMATION	1
1.1. Explanations of Symbols	1
1.2. General Information Regarding the User Manual	2
1.3. Manufacturer	2
1.4. Liabilities and Guarantees	2
1.5. Copyright Protection	3
2. PRODUCT INFORMATION	3
2.1. Product Label	3
2.2. Product Description	3
3. SAFETY	4
4. TRANSPORTATION, PACKAGING AND STORAGE	5
4.1. Delivery Control	5
4.2. Packaging	5
4.3. Storage	5
5. INSTALLATION	6
5.1. What to do Before Installation	6
5.2. Selecting the Installation Location	7
5.3. Electrical Connection	7
6. OPERATING	8
6.1. Using Digital Thermostat	9
6.2. Digital Thermostat Alarms	11
6.3. Digital Thermostat Errors	12
7. TURNING OFF THE APPLIANCE	13
8. PROBLEMS	13
9. CLEANING	14

9.1. Disposal.....	15
10. TECHNICAL INFORMATION	16
11. ELECTRIC SCHEME	30
12. DECLARATIONS	

12. GENERAL INFORMATION

12.1. Explanations of Symbols

In this manual, the following symbols are used to emphasize important safety instructions and recommendations for the product. The instructions should be carefully followed to avoid the risk of accidents, injuries and property damage.



PLEASE READ THE USER'S GUIDE!

Read these instructions before using the product and always keep it.



WARNING!

This symbol emphasizes the hazards that can cause injuries. Please carefully follow the instructions and pay particular attention to such situations.



WARNING ELECTRICAL HAZARD!

This symbol draws attention to possible electrical hazards. Failure to follow the safety instructions may result in injury or death.



NOTE!

This symbol emphasizes the tips and information to consider for efficient and trouble-free operation of the appliance.



CAUTION!

This symbol highlights instructions that must be followed to avoid risk of damage, errors and/or failure of the appliance.



GROUNDING

This symbol indicates that grounding is necessary and that it is compulsory under the law.



WASTE DISPOSAL

This symbol indicates that the product will not be considered as normal domestic waste. It emphasizes that waste disposal should be carried out.

12.2. General Information Regarding the User Manual

This user's guide contains information on installation, operation and maintenance of the appliance. It serves as an important information and reference guide.

In addition to the information provided here, you will need to act in accordance with current safety regulations for local health and safety controls. Knowing the safety and operating instructions in this manual will ensure that the appliance is used safely and correctly.

The installation manual is considered a part of the product and should be stored near the device so that it is accessible to anyone who will perform installation, service, maintenance or cleaning.

12.3. Manufacturer

ggmgastro
INTERNATIONAL

Tel: +49 (0) 2553 722 01 00 www.ggmgastro.com
info@ggmgastro.com

12.4. Liabilities and Guarantees

A new product is covered by a **12 month warranty** . All information and instructions in this manual take into consideration the standard safety regulations and up-to-date standard technical engineering levels, as well as the expertise and experience we have developed over the years.

If the supplied product is a special model, the actual scope of delivery may differ from the description and drawings in this manual. This also applies in the case of special orders or when the appliance is modified to be compatible with new technologies. You can access the production and technical information of the appliance you are using by informing our company of the serial number on the product label.

The manufacturer accepts no liability for any damage or malfunction that has occurred in the following circumstances and the product warranty will be void.

- Intentional damage, damage due to carelessness
- Not carrying out the applications specified in this guide
- Intervention by unauthorized persons
- Usage for unintended purposes

- Changes made by the user
- Use of non-original spare parts

12.5. Copyright Protection

The user's guide, including any text, drawings, images and other illustrations contained therein, is under copyright protection. No part of this publication may be reproduced, transmitted, or used in any form or by any means without the written permission of the manufacturer. Anyone involved in an unauthorized process involving this publication will be subjected to a claim for compensation. All Rights Reserved.

13. PRODUCT INFORMATION

13.1. Product Label

- Find the label on the product to read technical specifications.
- Check the appliance model and the power supply voltage before taking any action.
- The product is designed to operate in Climate Class 4 (30 C, 55%) and 5 (40 C, 40%).

Please contact the manufacturer or the supplier of the appliance if you encounter an inconvenient situation.

1 Manufacturer	
2 Manufacturer Contact Information	
3 Model Name	11 Rated Voltage
4 Serial Number	12 Frequency
5 Type of Appliance	13 Rated Power Input
6 Working Temperature	14 Defrost Power Input
7 Stroge Volume	15 Rated Current
8 Refrigerant / Mass	16 IP Number
9 Climate Class	17 Signs
10 Barcode	

13.2. Product Description

The appliance consists of the following basic sections and systems:

- Ventilated cooling system,
- Electrical system and parts,

- Electronic digital thermostat,
- Body insulated with environment friendly polyurethane material,
- Heating coil or hot gas defrosting system.

14. SAFETY

The products mentioned in this guide were designed and controlled according to national and international safety standards. The following rules should be followed for the safe use of the appliance.

- Never let the power cord to come into contact with heat sources or sharp surfaces.
- The power cable should not hang over the side of the working surface.
- Ensure that no one can step on or trip over the cable.
- The power cable must not be folded, bent or tangled, and must always remain fully unrolled.
- Never place the appliance or other objects on the power cable.
- Do not use the appliance if it does not function properly, is damaged or falls.
- Do not use any spare parts and accessories that are not recommended by the manufacturer. Otherwise, it may endanger the user or cause appliance damage or injuries. In this case, the warranty of your appliance will be void.
- Do not move or lift the appliance while it is operating.
- Do not place any objects on the appliance.
- Never touch the plug with wet or damp hands.
- Do not operate the appliance with wet hands or standing on a wet surface.
- Put the packaging material in a place that is absolutely inaccessible to children. Packaging materials (nylon, styrofoam, etc.) may pose danger to children.
- Do not damage the parts of the refrigeration cycle.
- Explosive materials such as aerosol cans with flammable propellant should not be stored in this product.
- In the event of a sudden power cut, unplug your appliance. To operate the appliance again, plug it back 20 minutes after the electricity is back. The high voltage that occurs when the electricity is first back may damage the product and cause fire.

**WARNING!**

Flammable gases such as R290A and R600A are used in this product. In the event of a fire resulting from any gas leakage or malfunction, disconnect the plug from the outlet or disconnect the appliance from the mains before attempting fire fighting.

**CAUTION!**

The installation, maintenance, and modifications of the machine should be performed by the authorized service.

15. TRANSPORTATION, PACKAGING AND STORAGE

15.1. Delivery Control

Please check right after the delivery if the product is complete and there is any damage due to transportation. Do not accept the delivery, or accept it conditionally if there are missing pieces or visible damage. Note down the scope of the damage on the delivery receipt of the courier. File the complaint. Damage records can only be registered within a certain period of time, thus a request should be made as soon as unseen damages are noticed.

15.2. Packaging

The inner and outer packaging of the appliance must be removed completely before installation.

**NOTE!**

Please observe the regulations in your country if you wish to dispose of the packaging. Recycle the usable packaging.

15.3. Storage

Do not unpack your product until the installation. Observe the positioning and storage marks located on the outside of the package. Packages must be stored under the following conditions.

- Do not keep it outdoors.
- Ensure that it stays dry and dust free.
- Avoid exposure to harsh conditions.
- Avoid exposure to direct sunlight.

- Keep away from mechanical shocks and vibrations.
- If it is necessary to store the product for at least 3 months, check the condition of the packaging and parts regularly.

16. INSTALLATION

16.1. What to do Before Installation

The following must be observed before using and installing the product.

- Your product is set to 220 - 240 Volt 50 Hz city electricity. Using different voltages may make your cooler unusable and cause a fire.
- The product you have purchased is designed to contain only chilled or frozen products. Please do not use for other purposes.
- Your product has no sterilization effect on microorganisms. For this reason, the food you put on your product must be in accordance with the hygiene requirements. Otherwise, microorganisms that breed in food can threaten your health.
- Do not place materials that should not be cooled into your product. Do not use your product to warm frozen foods.



WARNING ELECTRICAL HAZARD!

The power line to which the appliance is to be connected must have proper grounding. The manufacturer accepts no liability for any damage to the appliance caused by operation without or insufficient grounding.



CAUTION!

Do not overfill the shelves. The height of the materials you place on the shelves must not exceed half the distance between the two shelves to ensure air flow.

16.2. Selecting the Installation Location

The environment in which the appliance will operate in is very important for the product to operate properly. Before you install the product, pay attention to the following items.

- Do not position your product in a way that exposes your product to open air.
- In order to ensure proper chilling do not close or block the air inlets.
- Place your product away from sources that dissipate or may dissipate heat.
- Place your product away from intense air currents.
- Do not place your product under direct sunlight or near heat sources such as: heater, radiator, oven, stove, radiant and infrared. Otherwise, this may cause your product to perform poorly, be damaged and become unusable.
- Do not place your product on an inclined surface in order to avoid any falling and tipping problems.

16.3. Electrical Connection

To carry out the electrical connection of the product, unpack the all packaged parts, and then place the product where you want, taking into account the recommendations for the installation place in the user manual. Your product will work when you plug it into a suitable outlet.



CAUTION!

- Compare the local power transmission network specification and product label before connecting the product electrically.
- The manufacturer and the vendor shall not bear any responsibility if a high-voltage fuse (IN - 16 A ID - 30 ma) is connected to the power line.

- The outlet of your socket must be at least 16 A and grounded.
- The device must only be plugged into a properly installed single outlet with protective contact. Do not use any extension cords or multiple plugs. Do not unplug the power cord by pulling on the cable. Always hold the plug itself.
- The plug-in cable laying in places where people tend to walk around may cause injuries or damage to your product. Place the product accordingly.

**WARNING ELECTRICAL HAZARD!**

In case of improper installation and electrical connection, the appliance may cause injuries.

17. OPERATING

Before operating the product, clean the product in accordance with the cleaning instructions. The internal temperature of your product is adjusted in our factory so that it does not spoil your food and protect your food. You can control the internal temperature of the product from the digital thermostat display on the control panel. You can set the desired temperature again with this thermostat. If you operate your product at the factory set temperature, you will get the best results in terms of both performance and energy consumption.

**NOTE!**

Run the appliance for at least 2 hours before use. Thus, homogeneous temperature distribution is ensured throughout the device.

17.1. Using Digital Thermostat

The digital thermostat on the product is factory set and does not require adjustment. If you think there is a problem with the cooling of your device, please contact technical service.

The digital thermostat will lock itself for protection if no button is pressed for 30 seconds and "Loc" text is displayed for 1 second. If you press any key for 1 second, the display shows "Unl" for 1 second and the lock is unlocked. After unlocking, you can use the keys as follows.



It is used to change the set temperature and access the digital thermostat parameters.



Used to switch the device on or off. You can turn the device on and off by pressing and holding this key for 4 seconds.



Used to navigate between the parameters.



It is used to navigate between the parameters and run manual defrost operation.

The description of the symbols on the screen is as follows:



Compressor Light

If the light is on, the compressor is running.

If the light is flashing, the compressor will be activated or the set temperature value is changed.



Defrost Light

If the light is on, the defrost cycle has started.

If the light is flashing, the drip cycle will start.



Evaporator Fan Light

If the light is on, the evaporator fan is running.

If the light is flashing, the evaporator fan is in stand-by mode.

AUX

External Input

If the light is on, the interior light will operate in manual mode.

Anti-condensation heat coil will operate.

Alarm output will be active.

The door opening resistor will operate.

The condenser fan will operate.

If the light is flashing, the cabinet light will operate depending on the door switch input.



Energy Saving Light

Indicates the energy saving warning of the digital thermostat.



Repair-Maintenance Light

If the light is on, the device must be serviced or repaired.



Celsius Degree Light

If the light is on, Celsius is used as the temperature measurement unit.



Fahrenheit Degree Light

If the light is on, Fahrenheit is used as the temperature measurement unit.



On / Stand By Light

If the light is on, the device is turned off. (It is on stand by.)

17.2. Digital Thermostat Alarms

Alarm Code	Alarm Description	Solution	Result
AL	Minimum temperature alarm	-Check the room temperature. (A1 Parameter)	-The device will continue to operate normally.
AH	Maximum temperature alarm	-Check the room temperature. (A4 Parameter)	-The device will continue to operate normally.
id	Door switch alarm	-Check the reasons for input activation. (Parameter i0 and i1)	-Check i0 parameter.
iA	Multi-function input alarm or pressure switch alarm	-Check the reasons for input activation. (Parameter i5 and i6)	-Check i0 parameter.
COH	Condenser overheat alarm	-Check the condenser temperature. (C6 Parameter)	-The device will continue to operate normally.
CSd	Compressor shutdown alarm	-Check the condenser temperature. (C7 Parameter) -Turn the device off and then on again. If the condenser temperature is still higher than the value specified in parameter C7 when you turn on the device, disconnect the device from the mains and clean the condenser.	-Compressor will shut down.
dFd	The defrost alarm is switched off because the maximum time has been reached.	-Check the evaporator sensor. (parameter d2, d3 and d11) -Press any button to remove the text.	-The device will continue to operate normally.

The alarm icon disappears from the display when the causes of the alarms disappear. To eliminate only the "CSd" alarm code, it is necessary to turn the device on and off or disconnect the network. For the "dFd" alarm code, simply touch any key on the screen.

17.3. Digital Thermostat Errors

Error Code	Error Description	Solution	Result
Pr1	Room temperature probe error	<ul style="list-style-type: none"> -Check whether the probe is a PTC or NTC type. (P0 parameter) -Check probe connection. -Check the room temperature. 	<ul style="list-style-type: none"> -Compressor efficiency will depend on the C4 and C5 parameters. -Defrost will not be activated.
Pr2	Evaporator or condenser probe error	<ul style="list-style-type: none"> -Check to see whether the evaporator or condenser probe is PTC or NTC type. (P0 Parameter) -Check probe connection. -Check the evaporator or condenser temperature. 	<ul style="list-style-type: none"> -If parameter P4 is set to 1, the defrost interval will be set by the time parameter d3. -If parameter P4 is set to 1 and parameter d8 is set to 2 or 3, the device operates with parameter d8 set to 0. -If parameter P4 is set to 1 or 2 and F0 is set in parameter 3 to 4, the device will operate as parameter 2 set. -If parameter P4 is set to 3, the condenser overheat alarm ("COH" code) is never activated. -If parameter P4 is set to 3, the compressor shutdown alarm ("CSd" code) is never activated.

When the cause of the error is lost, the device continues to operate normally.

18. TURNING OFF THE APPLIANCE

To turn the cooler off, the following operations must be performed:

- 3- Switch off the device from the digital thermostat.
- 4- Unplug the power plug.

19. PROBLEMS

Problem	Probable Cause	Solution
<u>No power.</u>	<ul style="list-style-type: none"> -Main power supply is closed. -No voltage. -Other 	<ul style="list-style-type: none"> -Switch on the main switch. -Check outlet, cable and electrical connections. -Call the authorized service.
<u>The chiller works continuously but cannot reach the desired temperature.</u>	<ul style="list-style-type: none"> -External environment is too warm -Condenser is dirty. -Fan is broken. -Evaporator is frozen. -Digital thermostat is not working. -Heat detection probe is defective. 	<ul style="list-style-type: none"> -Provide air circulation. -Clean the condenser. -Check the fans. - Run manual defrost. -Check the door seal. -Call authorized service.
<u>The product makes too much sound while working.</u>	<ul style="list-style-type: none"> -Product not placed properly. -Loose screw or bolt -Other 	<ul style="list-style-type: none"> -Place the chiller on a flat surface. -Visually check the chilling component. -Call authorized service.
<u>Ice / moisture inside the appliance</u>	<ul style="list-style-type: none"> -Environment is too humid -The door was opened very often and / or had stayed open too long. -Damaged door seal 	<ul style="list-style-type: none"> -Check the door seal. -Call authorized service.
<u>Very high energy consumption</u>	<ul style="list-style-type: none"> -Environment is too hot -The door was opened very often and / or had stayed open too long. -Damaged door seal -Temperature setpoint is too low. -Too many product inside cupboard -The product is placed close to direct sunlight or heat dissipating surfaces. -Factory settings are changed. 	<ul style="list-style-type: none"> -Check the door seal. -Call authorized service.

20. CLEANING

The cleaning of the appliance should be divided into two parts as internal and external. Be sure to follow the instructions below before cleaning.

The appliance:

- For stainless steel parts: Use only warm water and non-aggressive detergents. Dry with a soft cloth.
- For polycarbonate and acrylic parts: Wash with warm water using a soft cloth or chamois cloth. Do not use abrasive cloths or sponges.
- For glass parts: Use specially manufactured products for glass cleaning. It is not recommended to use tap water which will cause calcium accumulation on the surface of the glass.
- Remove the product stored in the cooler compartment of the appliance and place it in the housing of a special refrigerator to ensure proper storage.
- Disconnect the appliance from the electrical outlet.
- Remove all equipment that can be removed manually.
- Wait 4 to 6 hours until the ice on the evaporator melts before starting cleaning. To accelerate the defrosting process, do not follow any process other than the one recommended by the manufacturer.
- Clean the side panels and the bottom of the pool with a mild detergent, warm water and a cloth or sponge. Do not use sharp tools. Rinse thoroughly and dry with an absorbent cloth.
- Connect the removed accessories.
- Switch on the appliance and wait until the temperature of the device has reached the desired temperature before returning the products to be stored.



NOTE!

-To clean the condenser, first unplug the appliance. Clean the dust on the condenser with proper cleaning fluids for condenser cleaning.

-It will directly affect the performance of the device.

-It is recommended to do condenser cleaning every 6 months.

**CAUTION!**

-When cleaning, do not scrape the ice on the device with sharp tools.
You can damage the surface.

-Do not use a water jet or steam hose as this may cause a short circuit in the electrical system.

20.1. Disposal

At the end of the period of use, the appliance to be disposed of must be done so in accordance with the national regulations. It is recommended to consult with a company specialized in waste disposal or to communicate with local disposal services.

**WARNING!**

To prevent misuse and danger, bring the waste equipment out of service before disposal. For this purpose, disconnect the device from the mains supply and disconnect the mains connection cable.

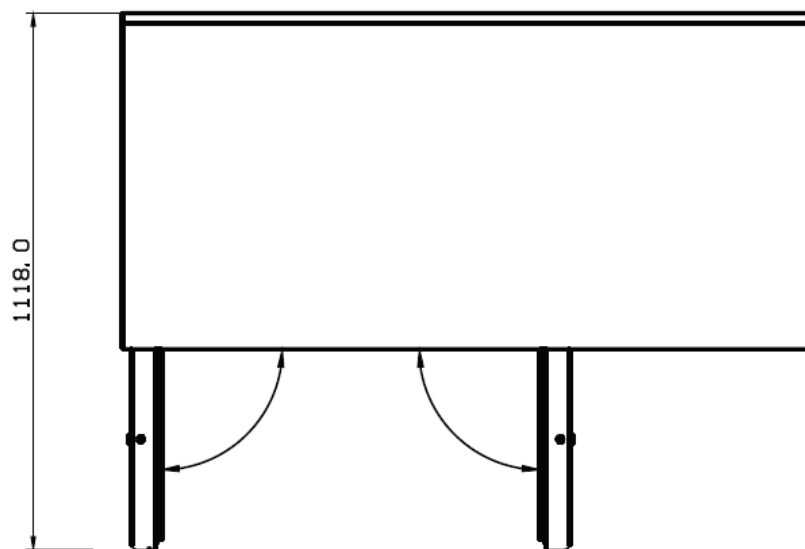
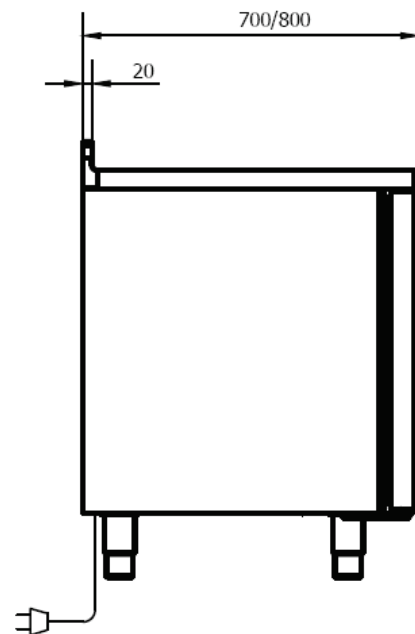
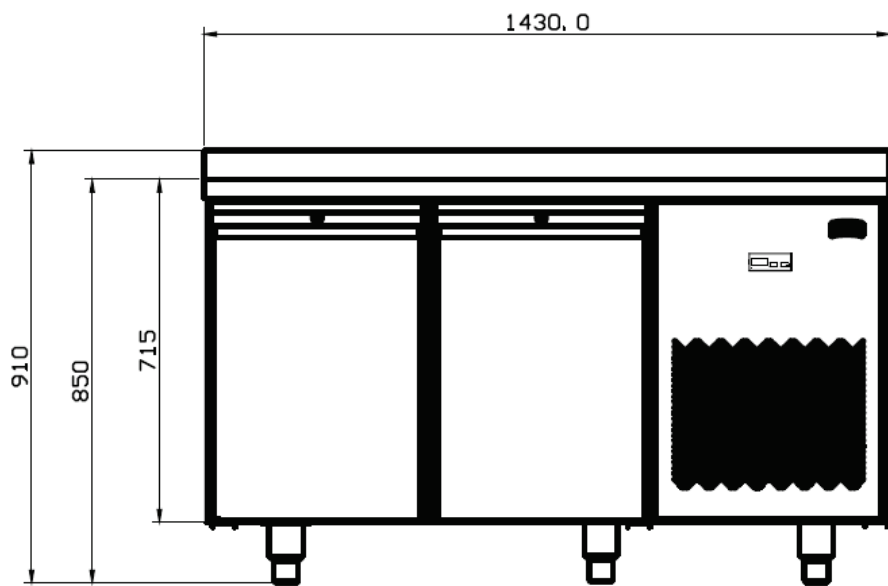

Model	Inner Temperature (°C)	Capacity (Lt)	Climate Class	Voltage (V/Hz)	Power (W)	Net Weight (kg)	Packaging Dimensions (mm)
KTC270BAR/ KTC270BAL	-2/+8	270	5	220- 230/50	350	120	1490x760x1000
KTC270BAR/ KTC270BAL	-2/+8	270+GN1/1x4	5	220- 230/50	350	130	1490x760x1000
KTC270BAR/ KTC270BAL	-2/+8	270	5	220- 230/50	450	370	1490x760x1000

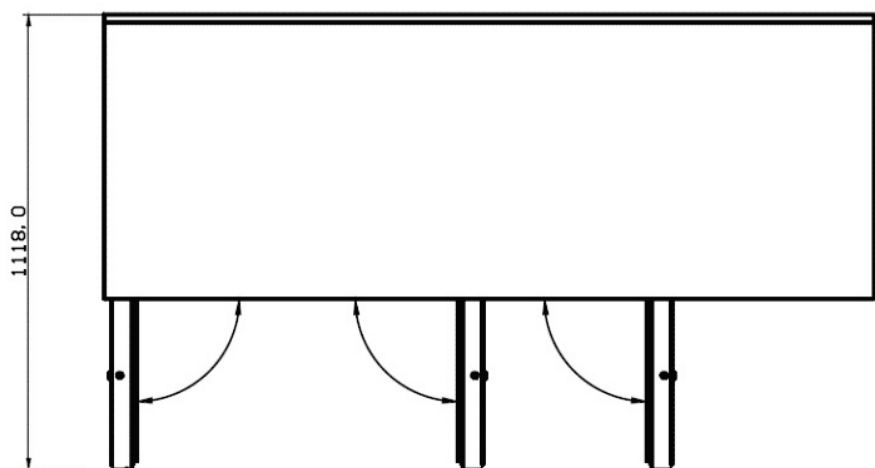
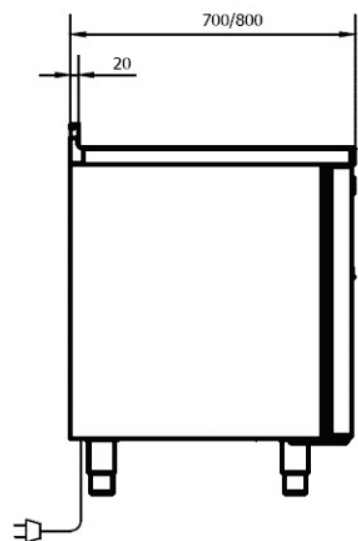
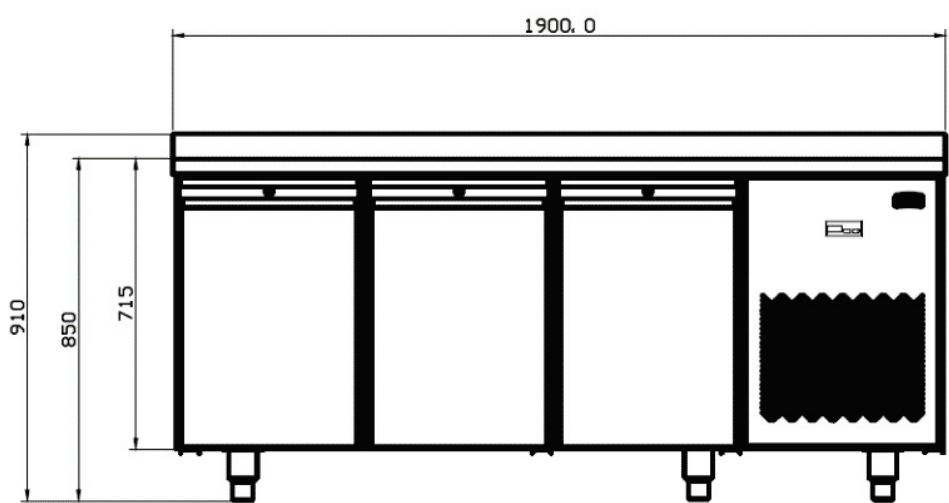

Model	Inner Temperature (°C)	Capacity (Lt)	Climate Class	Voltage (V/Hz)	Power (W)	Net Weight (kg)	Packaging Dimensions (mm)
KTC420BAR/ KTC420BAL	-2/+8	420	5	220- 230/50	350	150	1960x760x1000
KTC420BAR/ KTC420BAL	-2/+8	270+GN1/1x5	5	220- 230/50	350	165	1960x760x1000
KTC420BAR/ KTC420BAL	-2/+8	420	5	220- 230/50	450	410	1960x760x1000

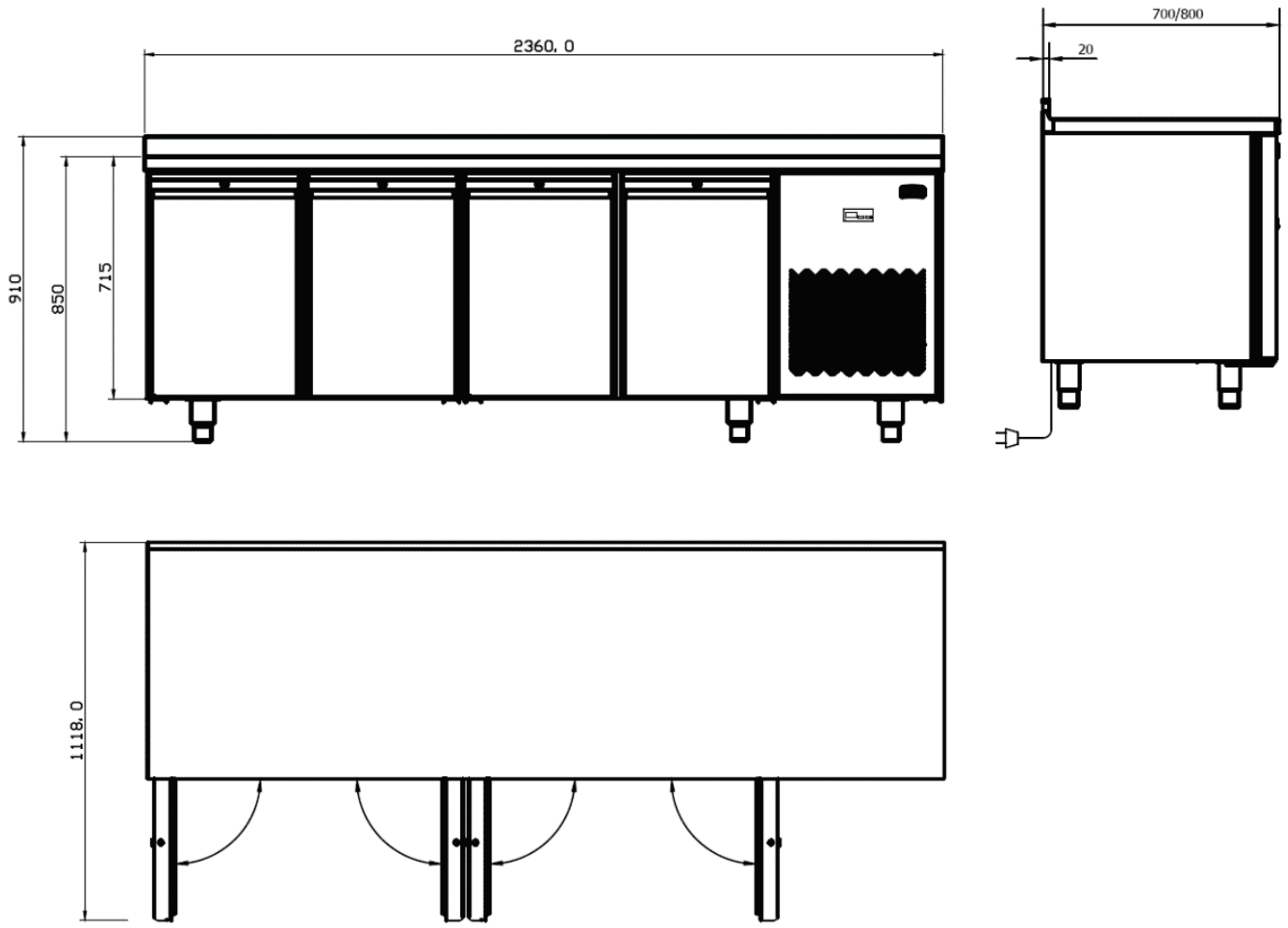

Model	Inner Temperature (°C)	Capacity (Lt)	Climate Class	Voltage (V/Hz)	Power (W)	Net Weight (kg)	Packaging Dimensions (mm)
KTC540BAR/ KTC540BAL	-2/+8	540	5	220- 230/50	350	500	2410x760x1000
KTC540BAR/ KTC540BAL	-2/+8	540	5	220- 230/50	450	500	2410x760x1000