

**STKAF75 SPLIT-KÜHLLAGGREGAT // STKAF75 SPLIT COOLING
MATERIAL AND TECHNICAL CHARACTERISTICS MANUEL
HANDBUCH FÜR MATERIAL UND TECHNISCHE MERKMALE**



STKAF75 SPLIT-KÜHLLAGGREGAT // STKAF75 SPLIT COOLING MATERIAL AND TECHNICAL CHARACTERISTICS MANUEL HANDBUCH FÜR MATERIAL UND TECHNISCHE MERKMALE

ANHANG : / INDEX :

- 1. EIGENSCHAFTEN/ CHARACTERISTICS**
- 2. INNERE UND ÄUSSERE ABMESSUNGEN / INSIDE , OUTSIDE DIMENSIONS**
- 3. EXPLOSIONSBILDER/ EXPLODED VIEW**
- 4. ERSATZTEILLISTE / SPARE PART LIST**
- 5. GAS- UND ELEKTRIZITÄTSSCHEMA / GAS AND ELECTRICAL SCHEMA**

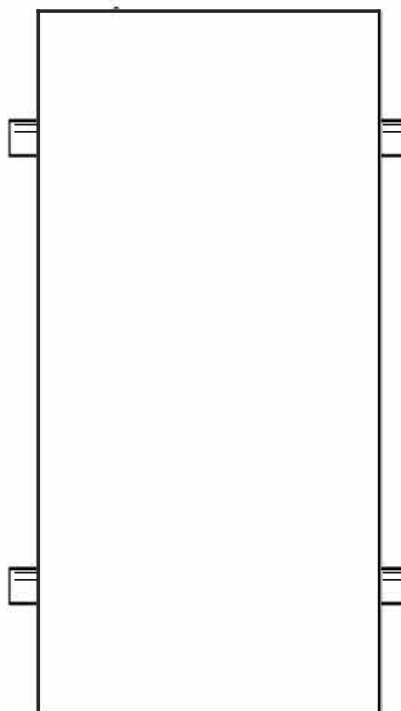
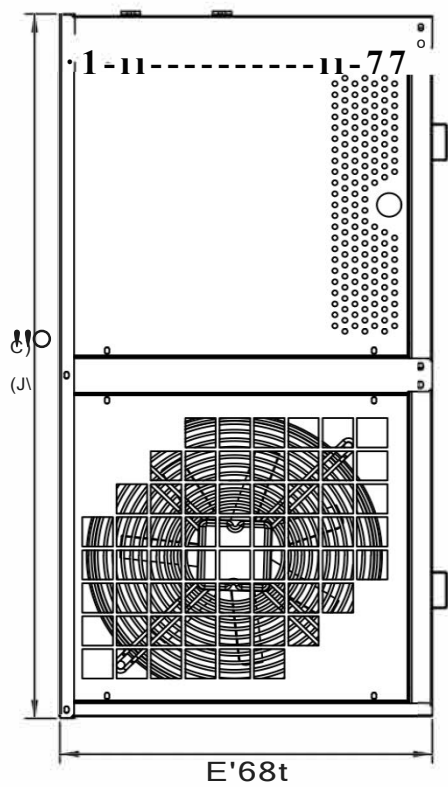
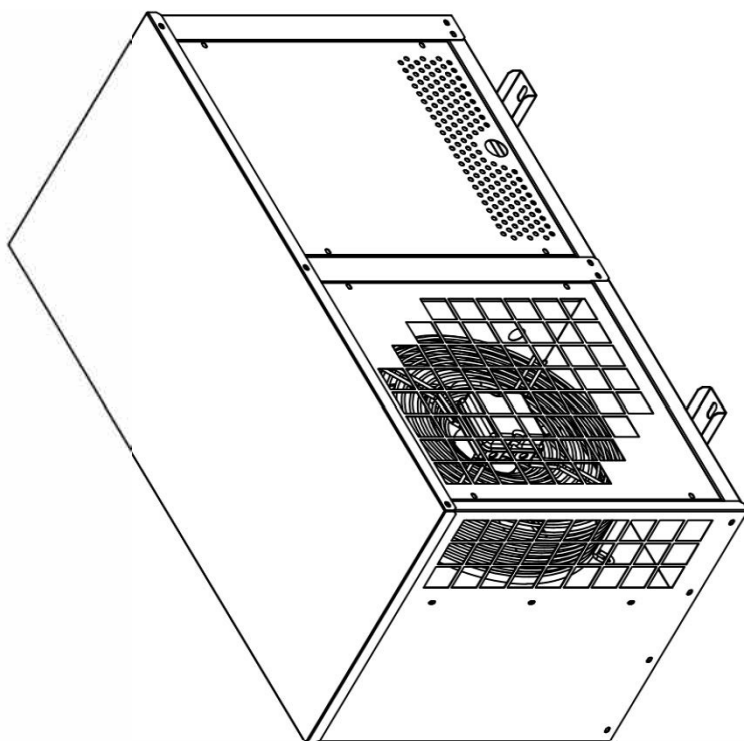
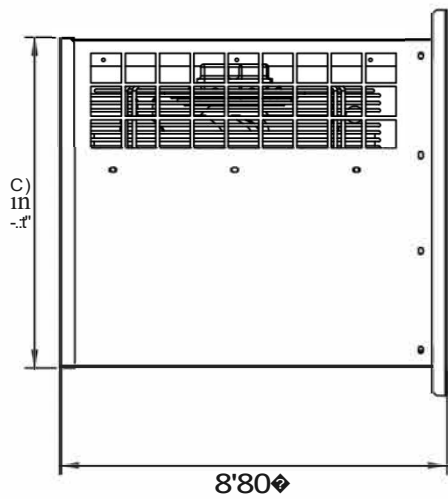

STKAF75 --EIGENSCHAFTEN // STKAF75 -- SPECIALITIES

Klima-Klasse / Climate Class	:T
Sicherheitsklasse/ Safety Class	:1
Betriebstemperatur/ Working Tempature C	:0C / -20C
Thermoster Einstelltemperatur / Thermostate Set Tempature	:-20C
Umgebungstemperatur/ Environment Tempature	:+43C
Umgebungsluftfeuchtigkeit/ Environment Moisture Propertion	:%65
Energieverbrauch / Energy Consuption	:0,65 KW/h
Strom/ Power	:1+1/2 HP
Spannung - Frequenz/ Voltage- Frekans	:220-230V / 50-60 Hz
Digitaler Thermostat / Digital Thermometer	:Digitales Thermometer
Energie Lampe/ Energy Lamp	: Ad / PCC1

TECHNISCHE DATEN / TECHNICAL CHARACTERISTICS

Äußere Abmessungen / Outside Dimensions	:660x1120x1000mm
Verpackung Abmessungen / Package Dimensions	:760x1220x1100mm
Internes Volumen/ Inside Volume	: 3.0 -- 7.5 m3
Bruttogewicht / Gross Weight	: 111 kg
Nettogewicht/ Net Weigt	: 91 kg
Kompressor/ Compresor	:1+1/2 HP-- NT 2212(3,0-7,5 m3)
Kondensator / Condanser	: 3900W--Kondanser (3,0-20,0 m3)
Verflüssigerlüfter/ Condanser Fan	: 165W--230V-50HZ Ø350 (S4E350-AN02-50)
Verdampfer/ Evaporatör	: 1394W--Evap (EG130AC7-C21)
Verdampferlüfter / Evaporatör Fan	: KÜHLRAUM TIEFKÜHLUNG 250 LÜFTER
Trockner-Filter / Dryer	: GMC--3/8" (SC083S) 45bar
Kältemittel Gas/ refrigerator Gas	: R404 A
Kältemittelmenge / Ref. Gas Quantity	:
Zertifizierungen/ Certifications	: TS 2225 EN 60335-2-4' ist konform.
Serien-Nr. / Serial No	: Sie wird an die entsprechende Stelle geschrieben, um im verpackten Zustand gelesen werden zu können/ Packed And Easy Read
Verpackung / Packing	: Alta Holzpalette, Karton und Luftnylon innen/ Wooden Palet is Down And Covered

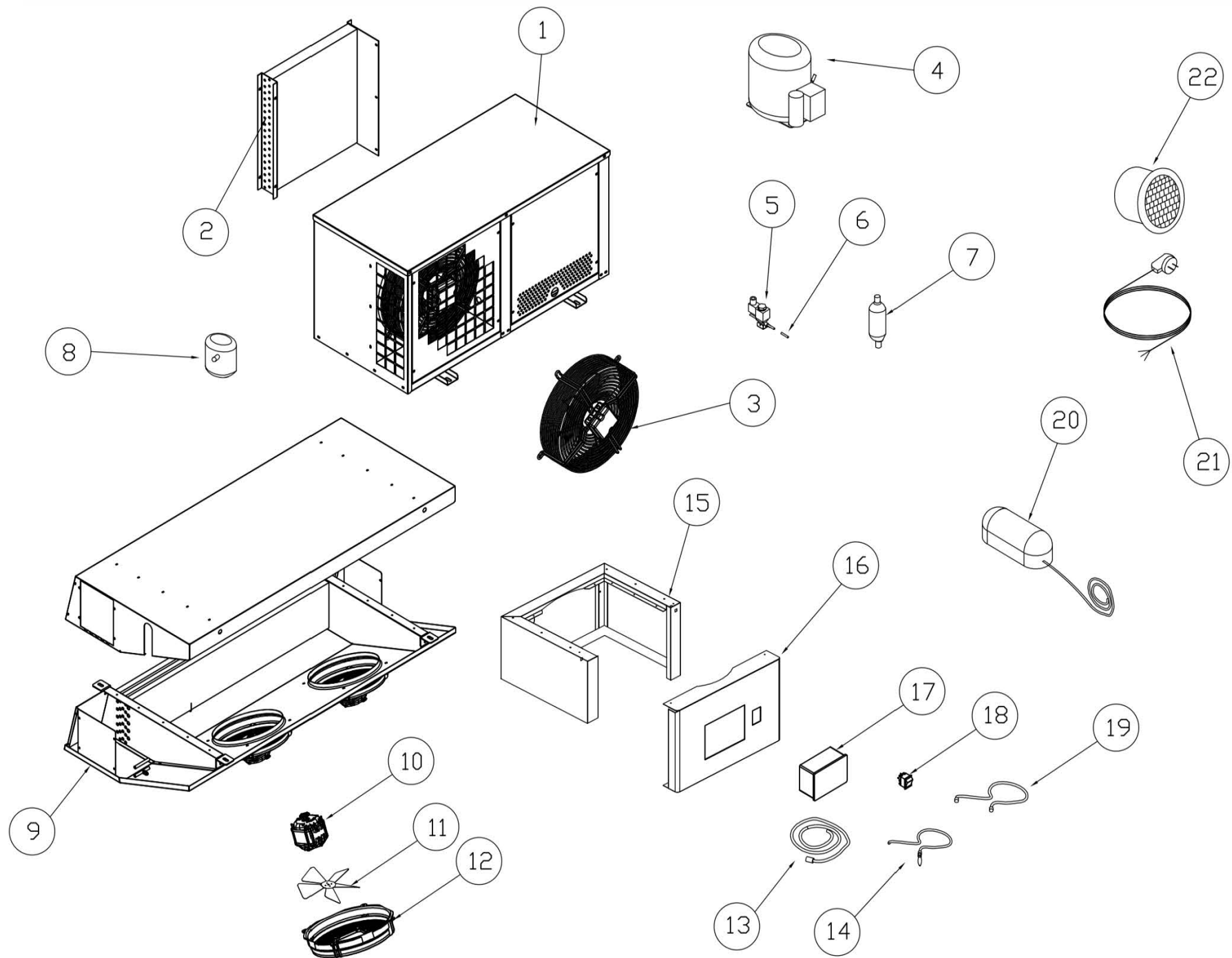

STKAF75 ERSATZTEILLISTE // STKAF75 SPARE PART LIST

NR	STOCK NR	TEIL NAME	MATERIAL NAME	Menge QTY
1	A00KN800	KARBOX-KÜHLGRUPPE	KARBOX COOLING GROUP	1
2	A00KN800-A	KARBOX-KONDENSATOR (3900 W)	KARBOX CONDANSER (3900 W)	1
3	A00KN800-B	KARBOX-GEBLÄSEMOTORU(165W-Ø350)	KARBOX FAN MOTOR (165W-Ø350)	1
4	A00KO114	NT 2212 GK R404A	NT 2212 GK R404A	1
5	B00EX100	AUSGABENWERT	EXPENSION VALVE	1
6	B00EX101	EXPANSIONSVENTILNADEL	EXPENSION VALVE NEEDLE	1
7	A00DR102	DRAYER 3/8" (GMC)	DRAYER 3/8" (GMC)	1
8	B00LT100	FLÜSSIGKEITSTANK	LIQUID TANK	1
9	A00EV253	EVAP GRUpeU-1394W--Evap (EG130AC7-C21)	EVAP GROUP-1394W--Evap (EG130AC7-C21)	1
10	A00EV253-A	LÜFTERMOTOR	FAN MOTOR	2
11	A00EV253-B	25cm PERVANE	25cm FAN	2
12	A00EV253-C	LÜFTERSCHUTZ KUNSTSTOFF	FAN PLASTIC	2
13	A00DJ109	PROP (3MT)	PROP (3MT)	1
14	A00DJ109	PROP (1,5MT)	PROP (1,5MT)	1
15	SG20176150	VERSCHÜTTETES ELEKTROKASTENBLECH	SPLIT ELECTRIC BOX SHEET	1
16	SG20176152	VERSCHÜTTETES ELEKTROKASTENBLECH	SPLIT ELECTRIC CANOPY BOX SHEET	1
17	A00DJ156	EVCO DIGITAL	EVCO DIGITAL	1
18	B00DU102	EIN- UND AUS-TASTE	ON OFF SWITCH	1
19	A00DJ108	ZWISCHENKABEL	DISPLAY CONNECTION CABLE	1
20	B00LA142	LED LAMPE	LED LAMP	1
21	B00FK100	NETZKABEL	PLUG CABLE	1
22	B00SL103	DRUCKVENTIL	PRESSURE VALVE	1
23	B00DU106	TÜRSCHALTER	DOOR SWITCH	1

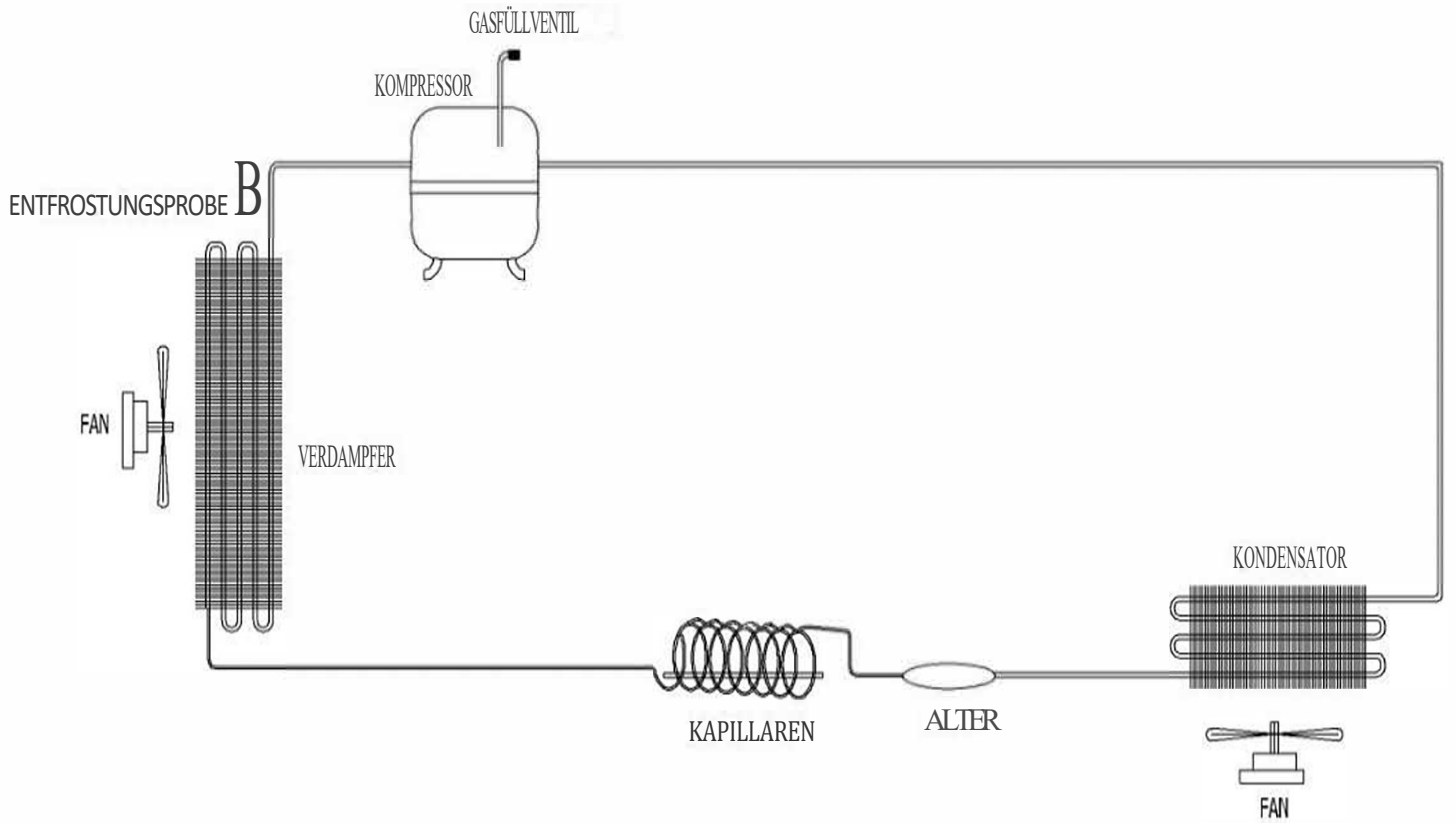

KALTRAUM ELEKTRISCH Schaltplan/ COLD ROOM ELECTRICAL SCHEMA

TÜRWIDERSTAND 230V L L

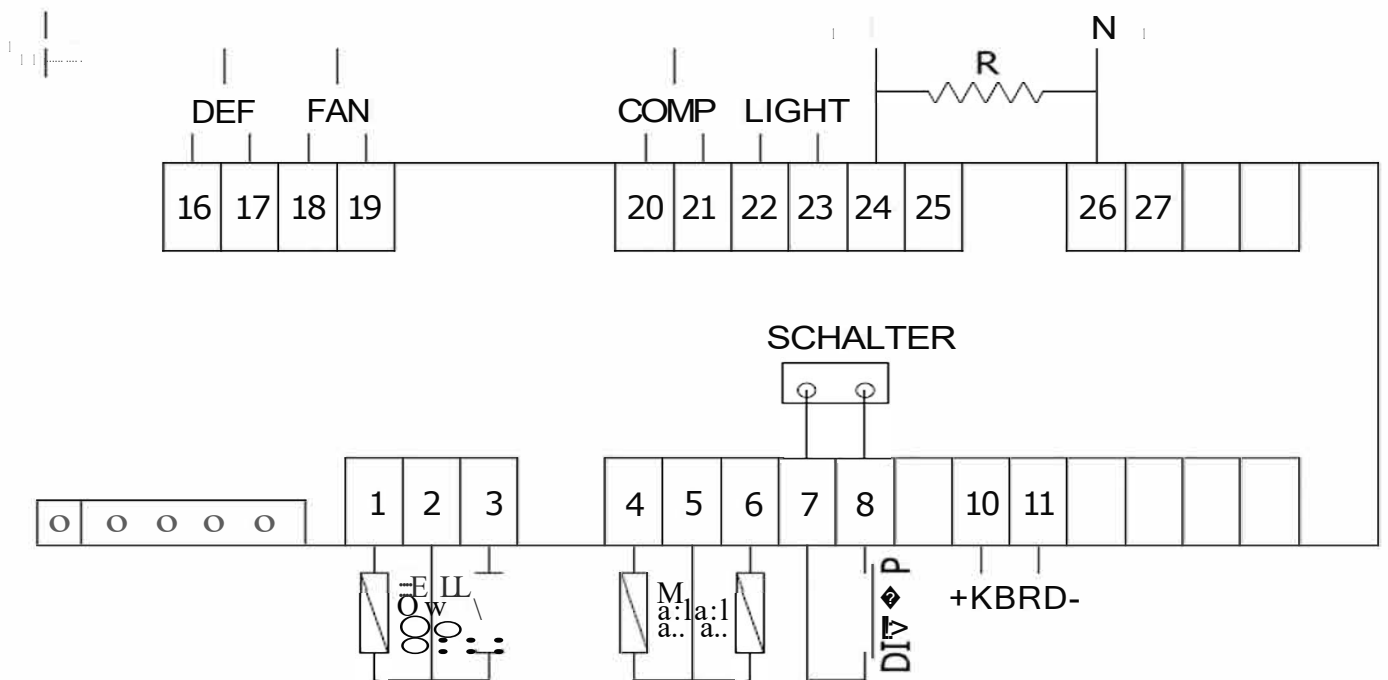

R: TÜRWIDERSTAND/ DOOR REZISTANCE