

SGL3050-GGM-EVC-R452
PANEL SOĞUTMA // PANEL COOLING
MALZEME VE TEKNİK ÖZELLİKLER DOSYASI
MATERIAL AND TECHNICAL CHARACTERISTICS MANUEL

İÇİNDEKİLER / INDEX :

- 1- KARAKTERİSTİK / CHARACTERISTICS
- 2- İÇ VE DIŞ ÖLÇÜLER / INSIDE , OUTSIDE DIMENSIONS
- 3- PATLAMIŞ RESİMLER / EXPLODED VIEW
- 4- YEDEK PARÇA LİSTESİ / SPARE PART LIST
- 5- GAZ VE ELEKTRİK ŞEMASI / GAS AND ELECTRICAL SCHEMA

SGL3050-GGM-EVC-R452



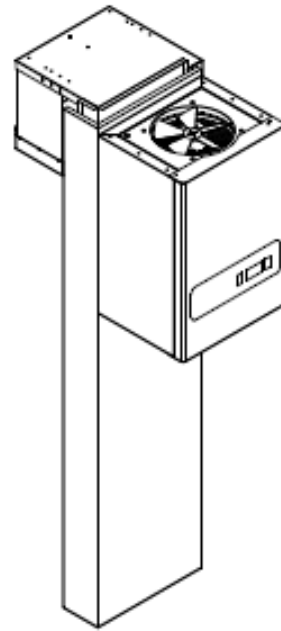
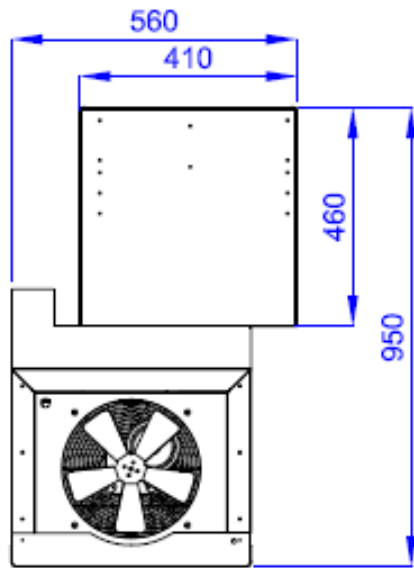
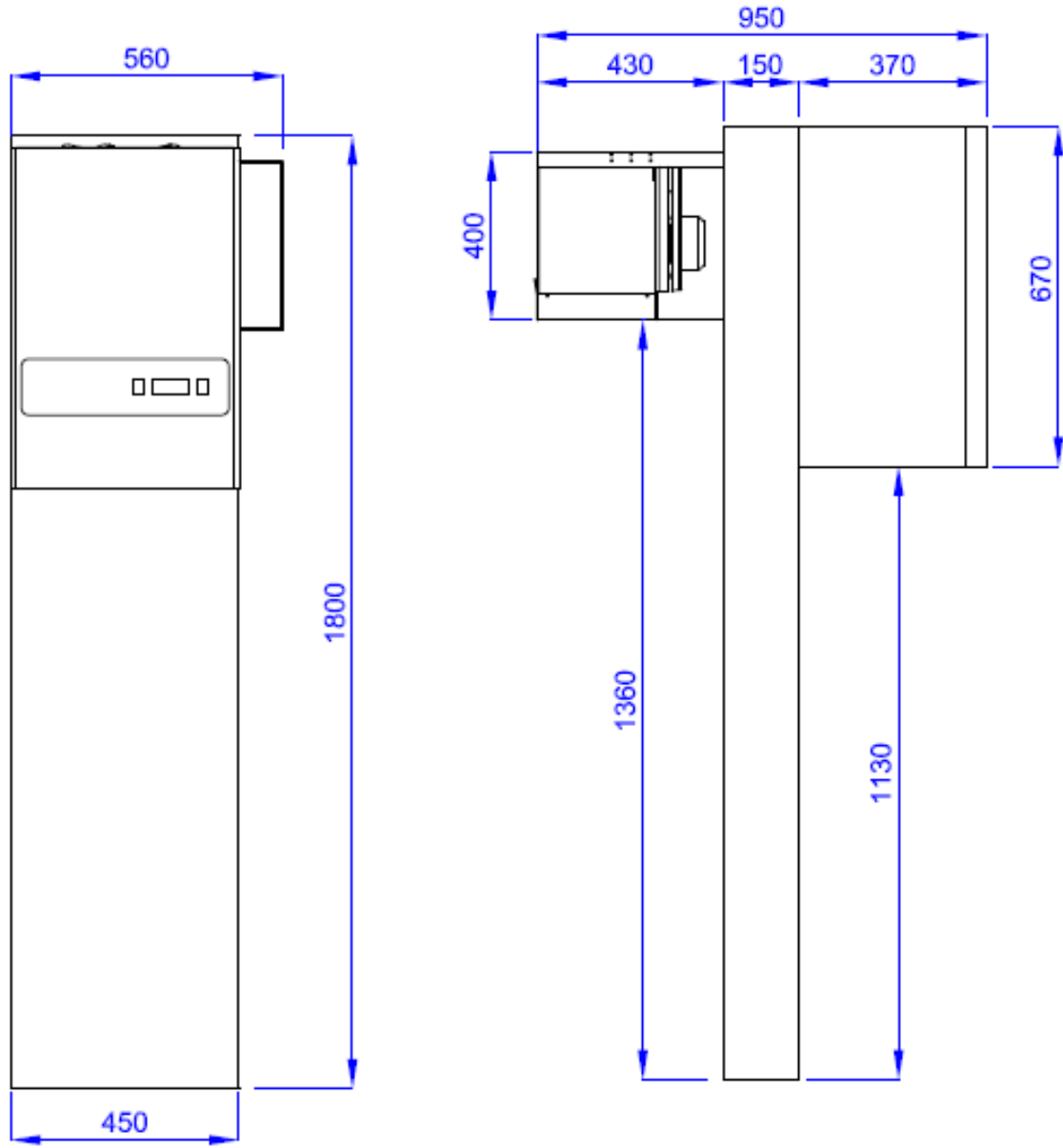

RESİM ADI / TANIM:

SGL3050

YERİ, MEYAN, YÖNÜ, DEĞERLERİ 750-75 M20

RESİM NO

MALZEME

ÖLÇÜLER

ÇİZEN

İLYAS YILMAZ

TARİH

06.06.2016

KONTROL

BAHRI İNCEÇAM

REV. NO :

Tarih:

Revizyon Sebepi:

ÖLÇÜ

1:1



SGL3050-GGM-EVC-R452 ÖZELLİKLER // SGL3050-GGM-EVC-R452 SPECIALITIES

İklim Sınıfı / Climate Class	:T
Güvenlik Sınıfı / Safety Class	:1
Çalışma Sıcaklığı / Working Temperature C	:-22°C / -10°C
Termoster Set Sıcaklığı / Thermostate Set Temperature	:-18°C
Ortam Sıcaklığı / Environment Temperature	:+43C
Ortam Nem Oranı / Environment Moisture Propertion	:%65
Enerji Tüketimi / Energy Consuption	:0,65 KW/h
Güç / Power	:1+1/2 HP
Voltaj- Frekans / Voltage- Frekans	:230V / 50 Hz
Dijital Termostat / Digital Thermometer	:Digital Thermometer
Enerji Lambası / Energy Lamp	: Ad / PCC1

TEKNİK ÖZELLİKLER / TECHNICAL CHARACTERISTICS

Dış boyutlar / Outside Dimensions	:560x950x1800mm
Ambalaj Boyutları / Package Dimensions	:620x1060x2000mm
İç Hacim / Inside Volume	: 3.0m ³ - 5.0 m ³
Brüt Ağırlık / Gross Weight	: 130 kg
Net Ağırlık / Net Weigt	: 120 kg
İç-Dış Gövde / Inside-Outside Body	: 0,50 mm PVC kaplı galvaniz beyaz sac. : 0,50 mm PVC coated galvanized white sheet.
Yalıtım Maddesi / Insulation Metarial	: 42 kg/m ³ Dantise Poliüretan 42 kg/m ³ Density Polyurethane
Yalıtım Maddesi Kalınlığı / Insulation Metarial Thicnes	: 120 mm
Kompresör / Compresor	: NJ 2212 GK R404 50Hz
Kondanser / Condanser	: 1700W--Kondanser (3,0-7,5 m ³)
Kondenser Fanı / Condanser Fan	: EBM--A2E250--230V-74A--115/165W
Evaporatör / Evaporatör	: 1150W--Evap (3,0-7,5 m ³) DİFRİZ
Evaporatör Fan / Evaporatör Fan	: EBM--S4E300--230V-40A--72/90W
Kurutucu Filtre / Dryer	: GMC--3/8" (SC083S) 45bar
Soğutucu Akışkan Gaz / refrigerator Gas	: R452 A
Soğutucu Akışkan Miktarı / Ref. Gas Quantity	: 950 gr
Onaylar / Certifications	: TS 2225 EN 60335-2-4' ye uygundur.
Seri No / Serial No	: Ambalajlı Halde Okunacak Şekilde Uygun Yere Yazılır / Packed And Easy Read
Ambalaj / Packing	: Alta Tahta Palet, Karton ve Havalı Naylon İçinde / Wooden Palet İs Down And Covered
Garanti Süresi / Qualty Time	: Kullanım Noktasına Ulaşımından İtibaren İmalat Hatalarına Karşı 2 Yıl. Her Ürün İle Garanti Belgesi ve Yetkili Servis Listesi Mevcuttur. / 2 Years After arriving the end user point. Warranty Certicate and User Manuel With the Unit.

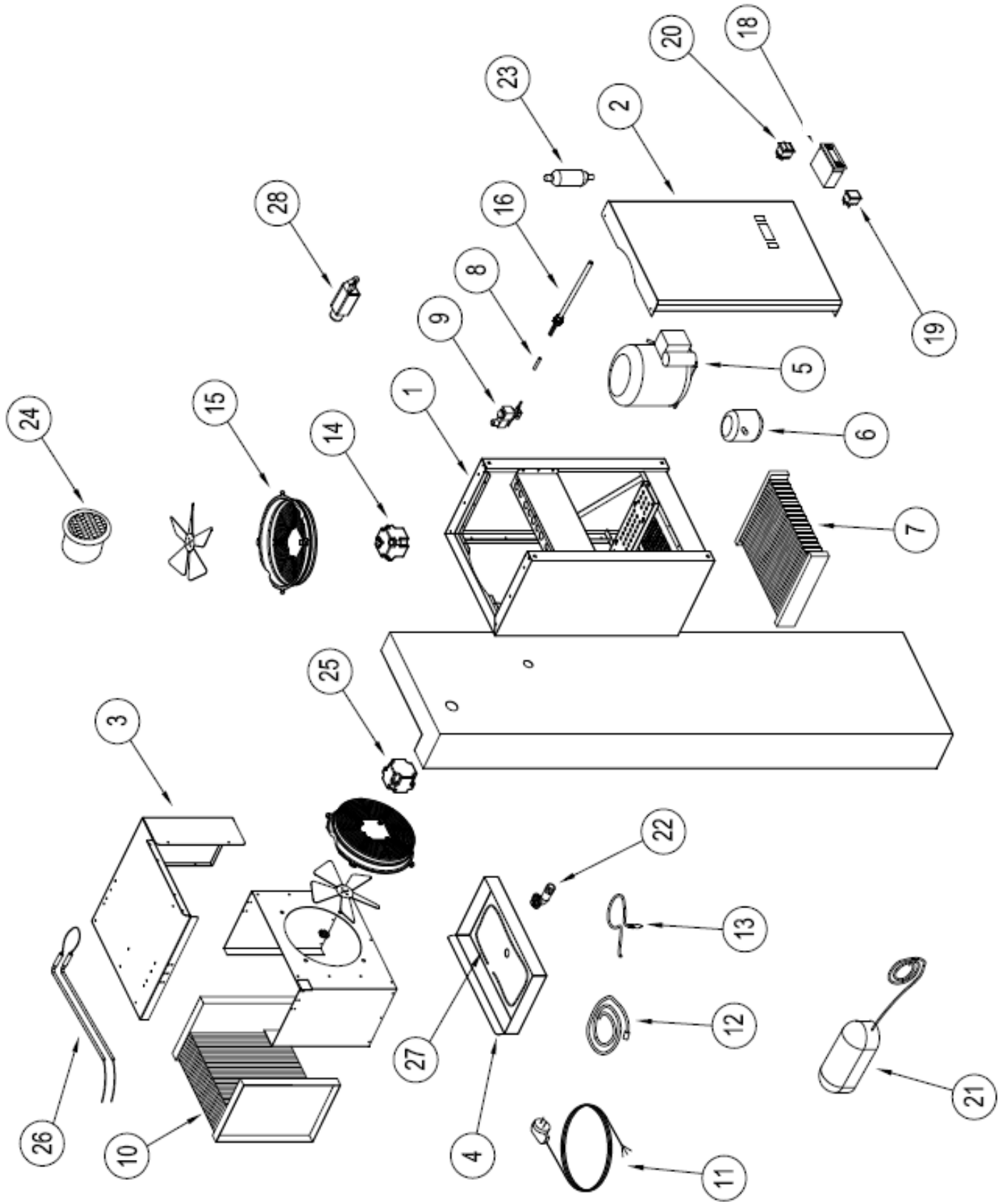

RESİM ADI / TANIM:

SGL3050

VERİLENEK TELESKOPİK BOZGÖRÜ: 7026 - 73 (402)

RESİM NO

MALZEME

ÖLÇÜLER

ÇİZEN

İLYAS YILMAZ

TARİH

06.06.2016

KONTROL

BAHRI İNCEÇAM

UK

MP

ALSD

LU

REVİZYON

NO

1

REVİZYON:

TARİH:

Revizyon Sebepi:



SGL3050-GGM-EVC-R452 YEDEK PARA LİSTESİ // SGL3050-GGM-EVC-R452 SPARE PART LIST

NO	STOK NO	PARA ADI	MATERIAL NAME	ADET QTY
1	SGL20130500	SOĐ.GRUBU GÖVDE SACI	COOLING GROUP BODY SHEET	1
2	SGL20130505	SOĐ.GRUBU KANOPI SACI	COOLING GROUP CANOPY SHEET	1
3	SGL20130503	SOĐ.GRUBU ARKA SACI	COOLING GROUP REAR SHEET	1
4	SGL20130502	SOĐ.GRUBU ALT SACI (SU TAVASI)	WATER BOX	1
5	A00K0122	NJ 2212 GK R404 50Hz	NJ 2212 GK R404 50Hz	1
6	B00LT100	LİKİT TANKI	LIQUID TANK	1
7	A00KN575	KONDANSER--(3,0-7,5 m3) 1700W	CONDANSER--(3,0-7,5 m3) 1700W	1
8	B00EX101	EXPENSION VALF İĐNESİ	EXPENSION VALVE NEEDLE	1
9	B00EX100	EXPENSION VALF	EXPENSION VALVE	1
10	A00EV115	EVAPARATÖR-(3,0-7,5 m3) 1150W	EVAPORATOR-(3,0-7,5 m3) 1150W	1
11	B00FK100	ŞEBEKE KABLOSU	PLUG CABLE	1
12	A00DJ109	PROP UCU (3mt)	PROP (3mt)	1
13	A00DJ102	PROP UCU (1,5mt)	PROP (1,5mt)	1
14	A00FA119	KOND.FAN MOTORU (EBM-115/165W)	KOND.FAN MOTOR (EBM-115/165W)	1
15	A00FA120	KOND.FAN KORUMA TELİ	KOND.FAN PROTECTION WIRE	1
16	B00REZ106	SU BUHARLAŞTIRMA REZİSTANSI	WATER EVAPORATION RESISTOR	1
18	A00DJ156	EVC ÖZEL DİJİTAL	EVC SPECIAL CONTROL PANEL	1
19	B00DU101	POWER TUŞU	POWER SWITCH	1
20	B00DU102	ON-OFF TUŞU	ON - OFF SWITCH	1
21	B00LA142	LED LAMBA	LED LAMP	1
22	B00EB102	EVAP ÇIKIŞ DİRSEĐİ	EVAP OUT ELBOW	1
23	A00DR102	DRAYER 3/8" (GMC)	DRAYER 3/8" (GMC)	1
24	B00SL103	BASINÇ VALFİ	PRESSURE VALVE	1
25	A00FA112	EVAP FAN MOTORU (EBM-72/90W)	EVAP FAN MOTOR (EBM-72/90W)	1
26	B00REZ123	400W--REZİSTANS	400W--RESISTANCE	1
27	B00REZ112	KAPI AĐZI REZİSTANS 7mt	DOOR RESISTANCE 7mt	1
28	B00DU106	KAPI SWITCH	DOOR SWITCH	1

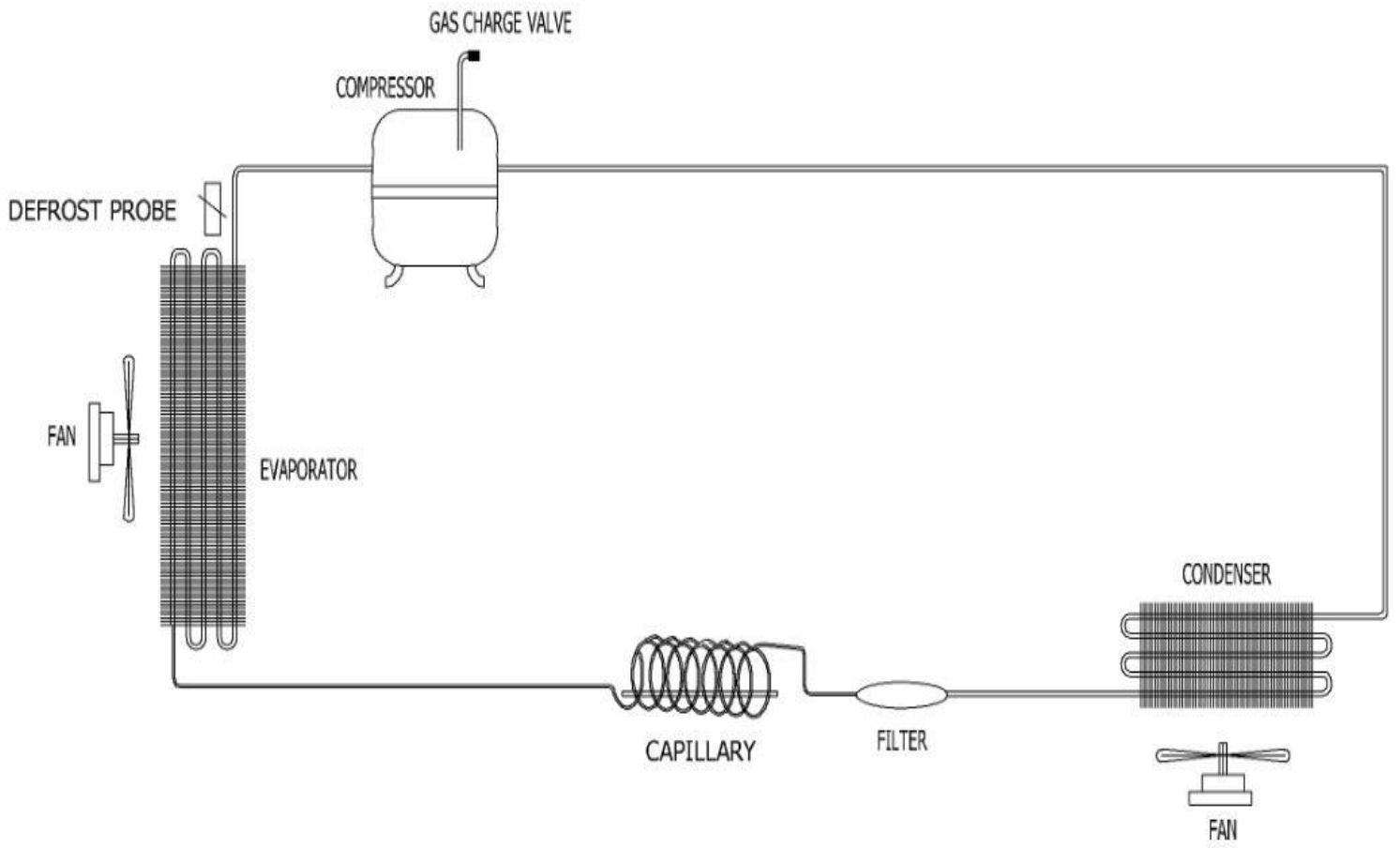

SOĞUK ODA (DİJİTALLİ) ELEKTRİK ŞEMASI
COLD ROOM (DIGITAL) ELECTRICAL SCHEMA

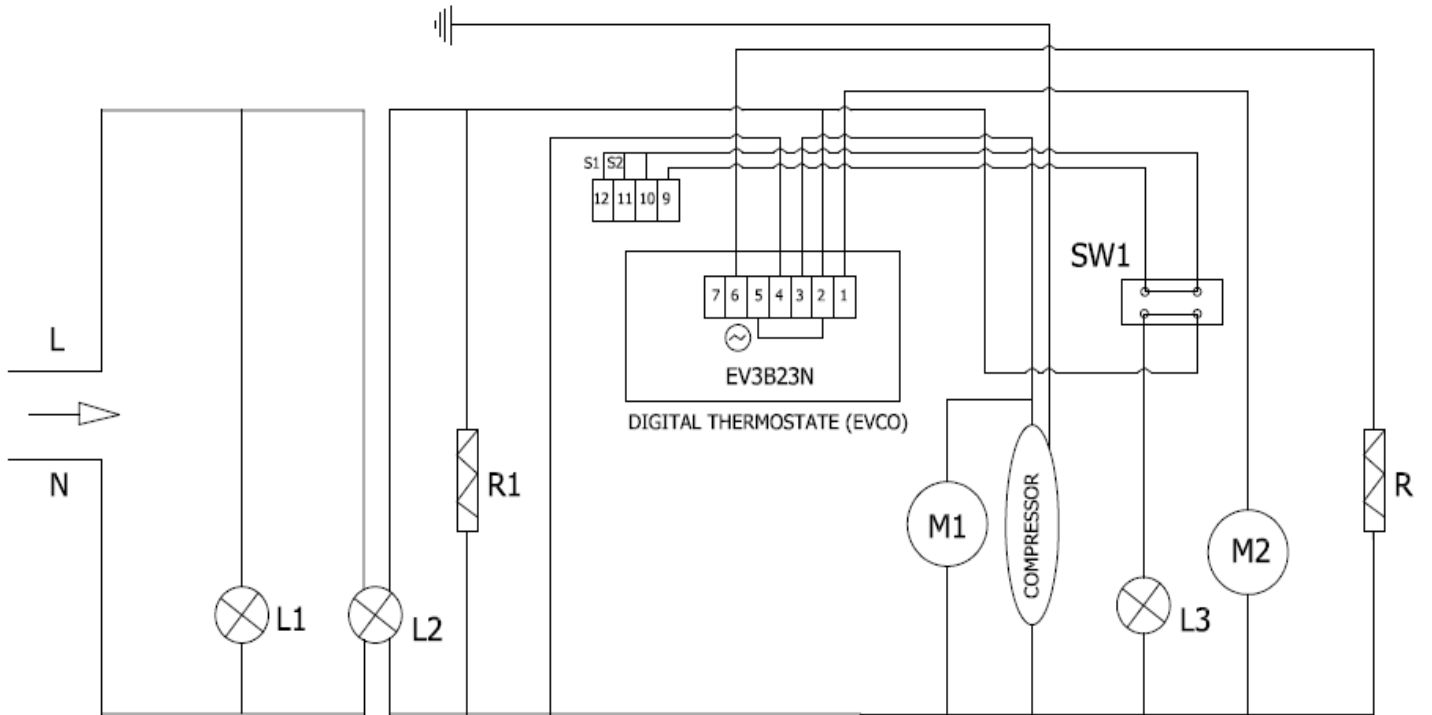

EV3B23N : DIGITAL THERMOTER / DİJİTAL TERMOSTAT
M1: KONDANSER FAN MOTORU / CONDENSER FAN MOTOR
M2 : EVAP FAN MOTOR / EVAP FAN MOTOR
S1 : ORTAM PROBU / ROOM PROB
S2 : EVAPARATÖR PROBU / EVAPORATE PROB

L1 : POWER LAMBASI / POWER LAMB
L2 : ACMA KAPAMA DÜĞMESİ / ON OFF BUTTON
L3 : ODA LAMBASI / ROOM LIGHT
R: EVAPORATOR REZİTANSI / EVAPORATE REZISTANCE
R1 : KAPI REZİTANSI / DOOR REZISTANCE
SW1 : KAPI SWİÇ / DOOR SWITCH