

BGKF216A

MALZEME VE TEKNİK ÖZELLİKLER DOSYASI MATERIAL AND TECHNICAL CHARACTERISTICS MANUEL

İÇİNDEKİLER / INDEX :

1. KARAKTERİSTİK / CHARACTERISTICS
2. İÇ VE DIŞ ÖLÇÜLER / INSIDE , OUTSIDE DIMENSIONS
3. PATLAMIŞ RESİMLER / EXPLODED WIEV
4. YEDEK PARÇA LİSTESİ / SPARE PART LIST
5. GAZ VE ELEKTRİK ŞEMASI / GAS AND ELECTRICAL SCHEMA



BGKF216A

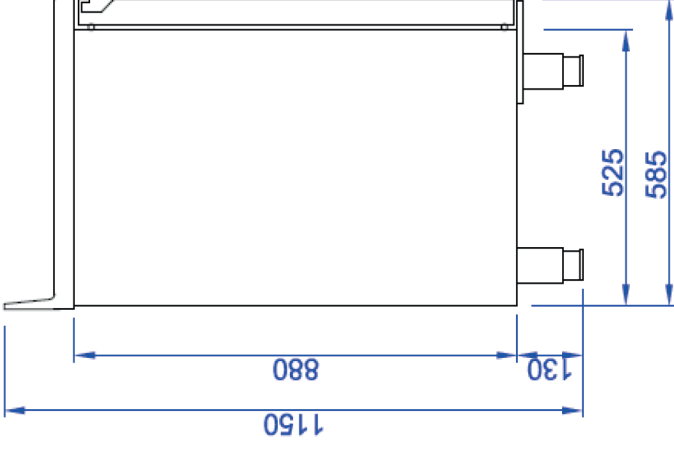
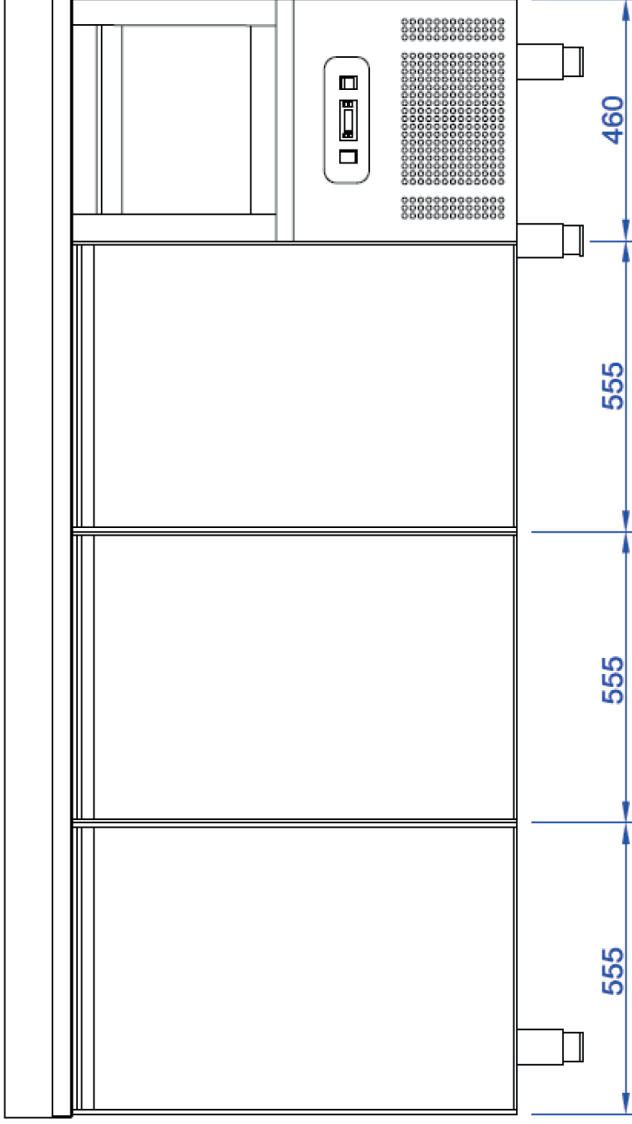

DIŐ BOYUTLAR / OUTSIDE DIMENSIONS = 2135x600x1150
İÇ BOYUTLAR / IN SIDE DIMENSIONS = 1545x465x795

RESİM ADI / TANIM:
drawing name

BGKF216A

BGKF216A

KARAKTERİSTİK ÖZELLİKLERİ / CHARACTERISTIC SPECIALITIES

İklim Sınıfı / Climate Class	:T
Güvenlik Sınıfı / Safety Class	:1
Çalışma Sıcaklığı / Working Tempature C	:-2C / +8C
Termoster Set Sıcaklığı / Thermostate Set Tempature	:-1C
Ortam Sıcaklığı / Environment Tempature	: +43C
Ortam Nem Oranı / Environment Moisture Propertion	: %65
Enerji Tüketimi / Energy Consuption	:0,23 KW/H
Güç / Power	:0,40 KW
Voltaj- Frekans / Voltage- Frekans	: 240V / 50 Hz

AKSESUARLAR VE KONTROL LAMBALARI / ACCESORIES AND CONTROL SWITCHES

Dijital Termostat / Digital Thermometer	: Digital Thermometer
Enerji Lambası / Energy Lamp	: Ad / PCC1
Açma Kapama Düğmesi / Power Switch	: Ad / PCS1
Menteşe Grubu / Hinges Group	: Ad / PCS3
Ayak / Stand	: Ad/PCS 5 Paslanmaz Ayak / + stainlies Steel Stand
Raf /Shelf	:6Ad.Plastik Kaplı Raf/6 Unts Plastic Coated Shelf

TEKNİK ÖZELLİKLER / TECHNICAL CHARACTERISTICS

Dış boyutlar / Outside Dimensions	:2135x600x1150mm
İç Boyutlar / Inside Dimensions	:1545x465x795mm
Ambalaj Boyutları / Package Dimensions	:2235x700x1250mm
İç Hacim / Inside Volume	: 570 lt
Brüt Ağırlık / Gross Weight	: 210 kg
Net Ağırlık / Net Weigt	: 180 kg
Dış Gövde / Outside Body	: 0,60 mm I NOX 430 SB+PVC
İç Gövde / Inside Body	: 0,50 mm I NOX 430 MAT+PVC
Yalıtım Maddesi Kalınlığı / Insulation Metarial Thicnes	: 60 mm
Yalıtım Maddesi Yoğunluğu / Insulation Metarial Volur	: 42 Kg / m3 +/-1
Kompresör / Compresor	: EMT-6181 U (1/4HP)-R290
Kondanser / Condanser	: 1/2 Hp Davlumbazlı kondanser-R290
Kondenser Fanı / Condanser Fan	: 16/68W 15002SGFA01
Evaporatör / Evaporatör	: NTV tip evap / NTV type evap
Evaporatör Fan / Evaporatör Fan	: 13/37W - 2A 230V 50/60HZ
Kurutucu Filtre / Dryer	: 30 gr 15002SGDR02 Çift Girişili
Soğutucu Akışkan Gaz / refrigerator Gas	: R290 A
Soğutucu Akışkan Miktarı / Ref. Gas Quantity	: 110 gr
Onaylar / Certifications	: TS 2225 EN 60335-2-4' ye uygundur.
Seri No / Serial No	: Ambalajlı Halde Okunacak Şekilde Uygun Yere Yazılır / Packed And Easy Read
Ambalaj / Packing	: Alta Tahta Palet, Karton ve Havalı Naylon İçinde / Wooden Palet İs Down And Covered
Garanti Süresi / Quality Time	: Kullanım Noktasına Ulaşımından İtibaren İmalat Hatalarına Karşı 2 Yıl. Her Ürün İle Garanti Belgesi ve Yetkili Servis Listesi Mevcuttur. / 2 Years After arriving the end user point. Warranty Certicate and User Manuel With the Unit.

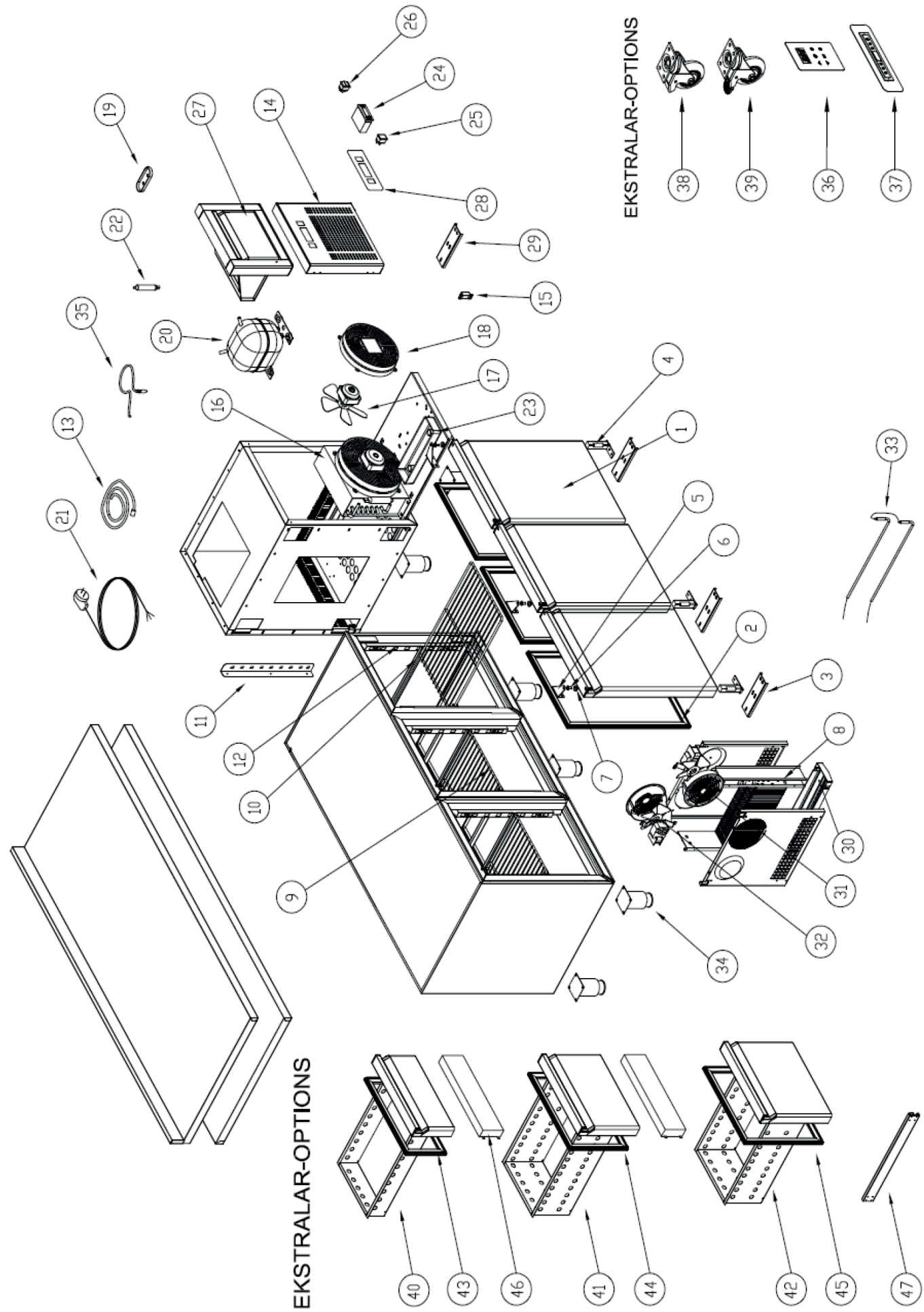

RESİM ADI / TANIM:

BGKF216A

YERLEMEYEN TOLERANS DEĞERLERİ

7226-73 (6/2)

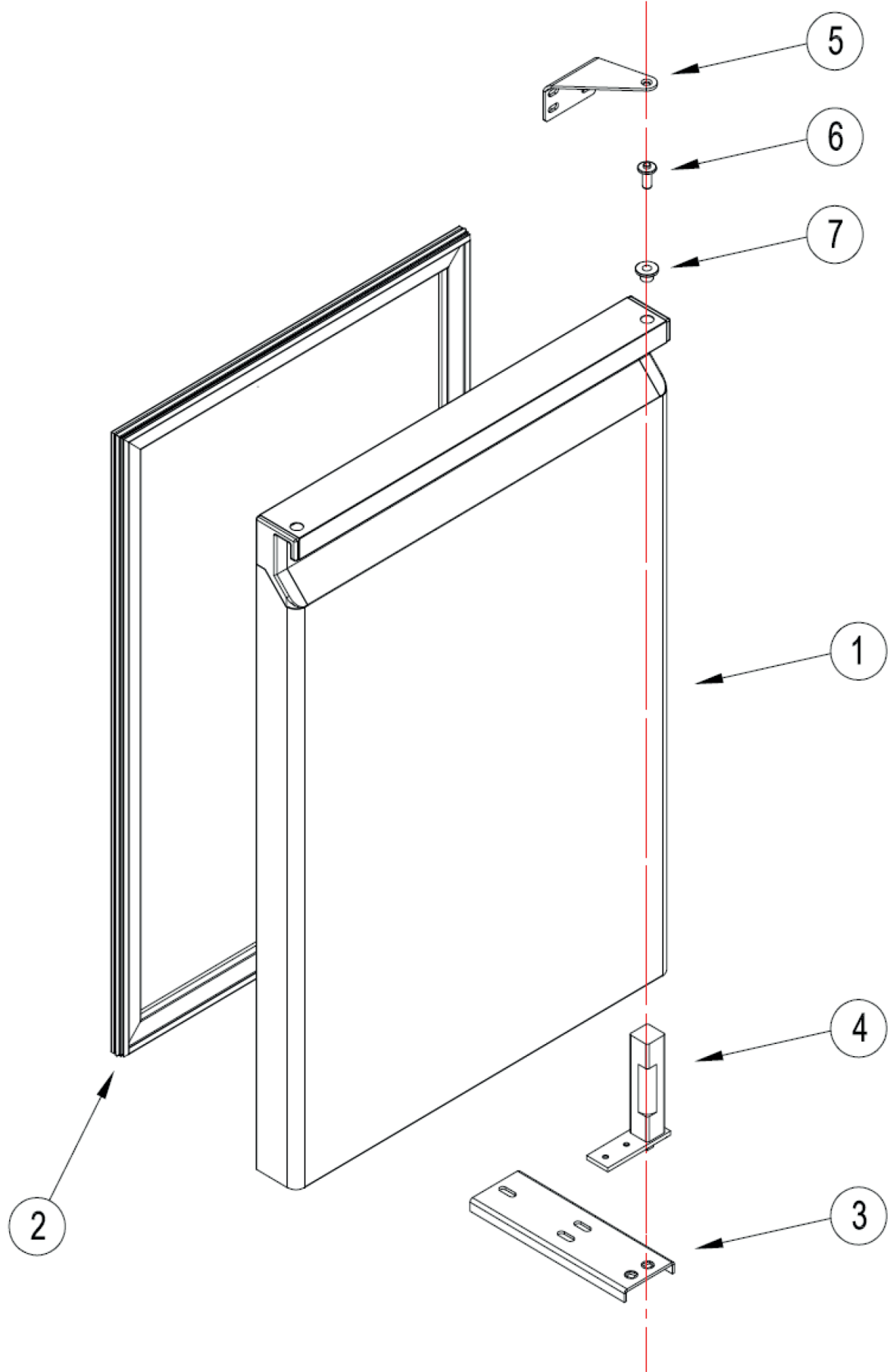

COUNTER TYPE REFRIGERATORS - DOOR DETIAL

RESİM ADI / TANIM:

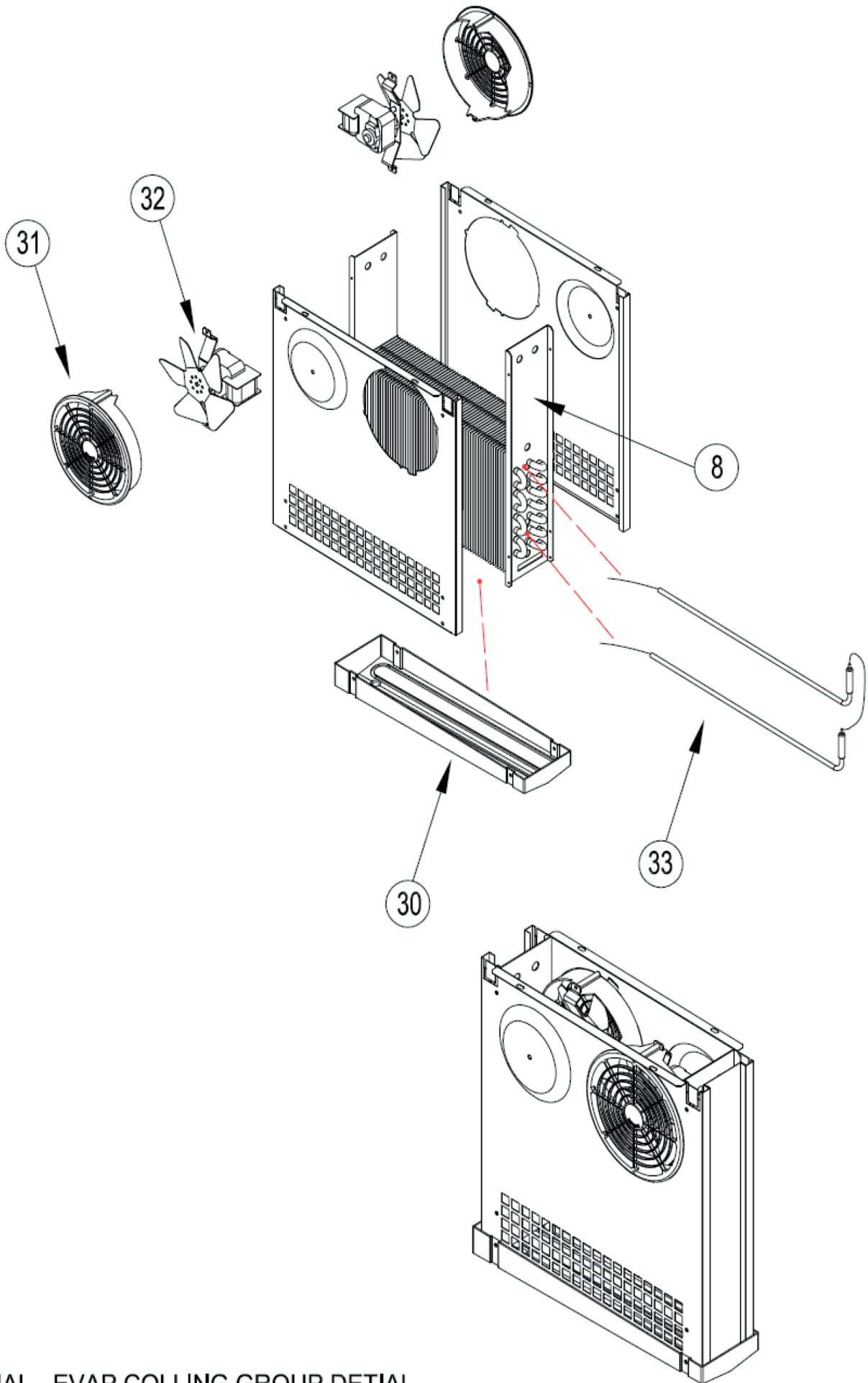

NORMAL - EVAP COLLING GROUP DETIAL

	RESİM ADI / TANIM:						
	VEHİCLEYEN TOLERANS DEĞERLERİ	728 - 73					

BGKF216A - YEDEK PARA LİSTESİ / SPARE PART LIST

NO	STOK NO	PARA ADI	MATERIAL NAME	ADET QTY
1	01A01KA141	KAPI	DOOR	3
	01A01KA142	CAMLI KAPI	GLASS DOOR	3
2	A00CO125	KAPI CONTASI	DOOR GASKET	3
3	30080007	MENTEŐE ALT BRAKETİ	LOVER HINGE BRACET	3
4	B02ME100	DİK DOLAP MENTEŐE TAKIMI	UPRIGHT HINGE AND PARTS	3
5	30080008	ÜST MENTEŐE	UPPER HINGE	3
6	B01ME104	ÜST MENTEŐE PİMİ	UPPER HINGE PIM	3
7	B01ME103	MENTEŐE PLASTİK BURCU	HINGE PLASTIC	3
8	A00EV100	EVAPORATOR	EVAPORATOR	1
9	B01RF124	RAF-KSN 440X405	SHELF-KSN 440X405	6
10	C17000126	RAF KIZAĐI 430mm	SHELF GUIDE - 430m	12
11	C06886015	RAF DİKMESİ - ARKA	SHELF RACKET - BACK	6
12	C06886016	RAF DİKMESİ - ÖN	SHELF RACKET - FRONT	6
13	A00DJ109	PROP UCU - 3mt	PROP	1
14	C06886019	KANOPI	CANOPY	1
15	B01ME112	MIKNATISLI MENTEŐE	MAGNET HINGES	2
16	A00KN111	1/2 Hp KONDANSER	1/2 Hp CONDANSER	1
17	A00FA109	10W-FAN MOTORU	10W-FAN MOTOR	1
18	A00EP101	KONDANSER FAN PLASTİĐİ	CONDANSER FAN PLASTIC	1
19	B00TK100	PROP KAPAĐI	PROP COVER	1
20	A00KO205	KOMPRESÖR-EMT-6181 U (1/4HP)	COMPRESSOR-EMT-6181 U (1/4HP)	1
21	B00FK100	ŐEBEKE KABLOSU	PLUG CABLE	1
22	A00DR100	DRAYER	DRAYER	1
23	B01BH102	KOMPRESÖR SU TAVASI	WATER BOX	1
24	A00DJ100-Dİ-C	ÇİFT PROPLU DİĐİTAL(DİXELL)	DIGITAL THERMOSTAT TWO PROPE(DİXELL)	1
25	B00DU101	POWER TUŐU	POWER SWITCH	1
26	B00DU102	ON-OFF TUŐU	ON - OFF SWITCH	1
27	01A01CK701	KAHVE ÇEKMECESİ	COFFEE DRAWER	1
28	A00DJ105	DİĐİTAL ETİKET	DIGITAL LABEL	1
29	P30080009	KANOPI MENTEŐESİ	CANOPY HINGE	1
30	B01BH101	EVAP SU TAVASI	EVAPORATOR CUP	1
31	A00EP100	FAN KORUMA PLASTİĐİ	PLASTIC FAN PROTECTION	2
32	A00FA102	EVAP FAN MOTORU	EVAP FAN MOTOR	2
33	B00REZ116	200W FİŐEK REZİSTANS	200W RESISTANCE	1
34	B00AY100	PASLANMAZ AYAK	STAINLESS STEEL LEG	5
35	A00DJ102	PROP UCU - 1,5mt	PROP	1
36	A00DJ139	SU GEÇİRMEZ DİĐİTAL	WATER PROOF DİĐİTAL	1
37	A00DJ120	TOUCH KONTROL DİĐİTAL	TOUCH CONTROL DIGITAL	1
38	B00AY101	TEKERLEK - FRENŐİZ	WHEELS	3
39	B00AY102	TEKERLEK - FRENLİ	WHEELS BRAKE	2
40	01A01CK734	1/3 ÇEKMECE (KSN)	1/3 DRAWERS (KSN)	
41	01A01CK723	1/2 ÇEKMECE (KSN)	1/2 DRAWERS (KSN)	
42	01A01CK735	2/3 ÇEKMECE (KSN)	2/3 DRAWERS (KSN)	
43	A00CO127	1/3 ÇEKMECE CONTA (KSN)	1/3 DRAWERS GASKET (KSN)	
44	A00CO126	1/2 ÇEKMECE CONTA (KSN)	1/3 DRAWERS GASKET (KSN)	
45	A00CO141	2/3 ÇEKMECE CONTA (KSN)	2/3 DRAWERS GASKET (KSN)	
46	01A01OR100	ÇEKMECE ORTA DİREK	DRAWERS MIDDLE BRIDGE	
47	A00CK101	ÇEKMECE RAYI 60LİK	DRAWER RAIL	
	01A01EV370	YATAY DOLAP EVAP GRUBU 3 KAPI	COUNTER REF EVAP GROUP 3 DOORS	1
	01A01EV372	YATAY ÇEKMECELİ EVAP	COUNTER REF EVAPARATOR DOUBLE	1

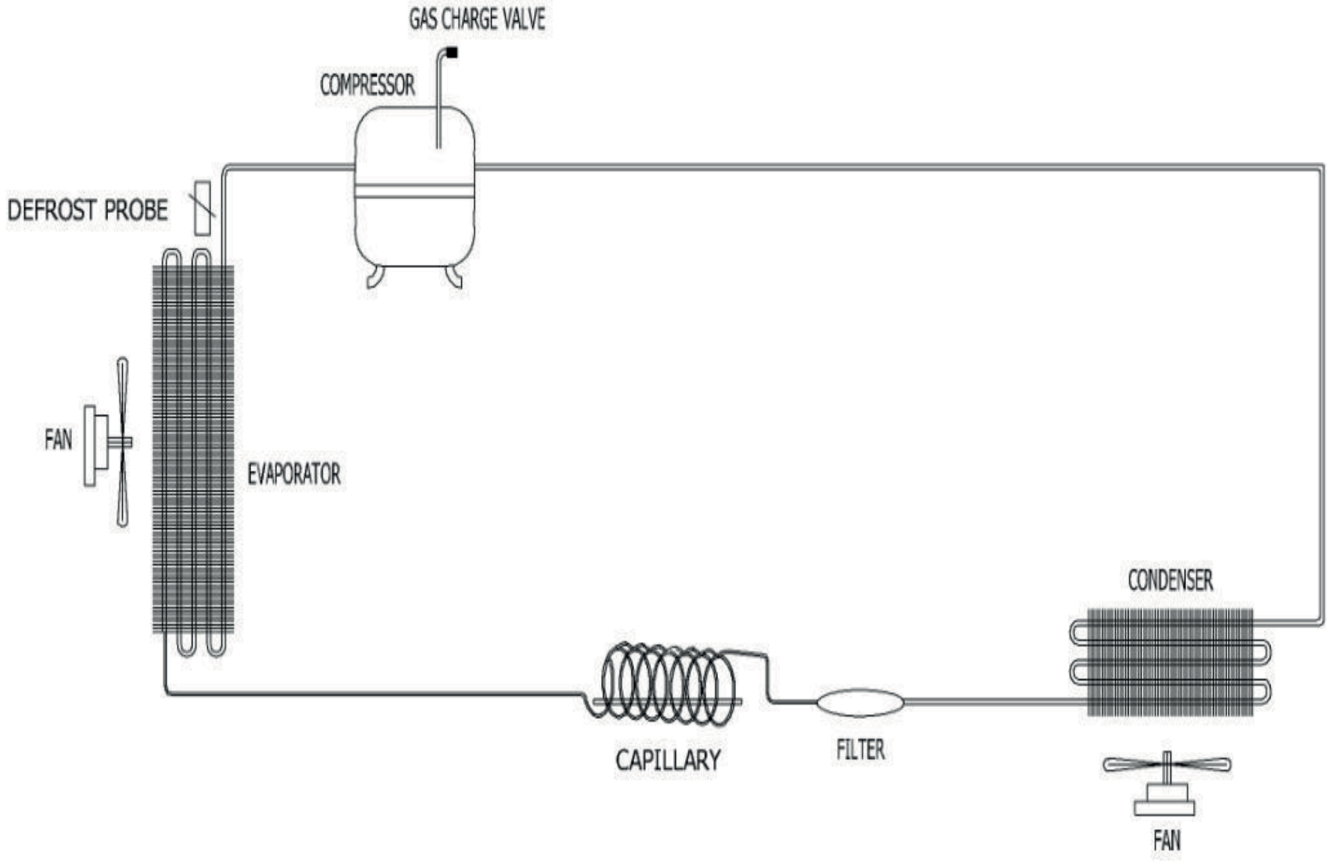

YATAY BUZDOLABI NORMAL ELEKTRİK ŞEMASI
HORIZONTAL REFRIGERATORS NORMAL ELECTRICAL SCHEMA

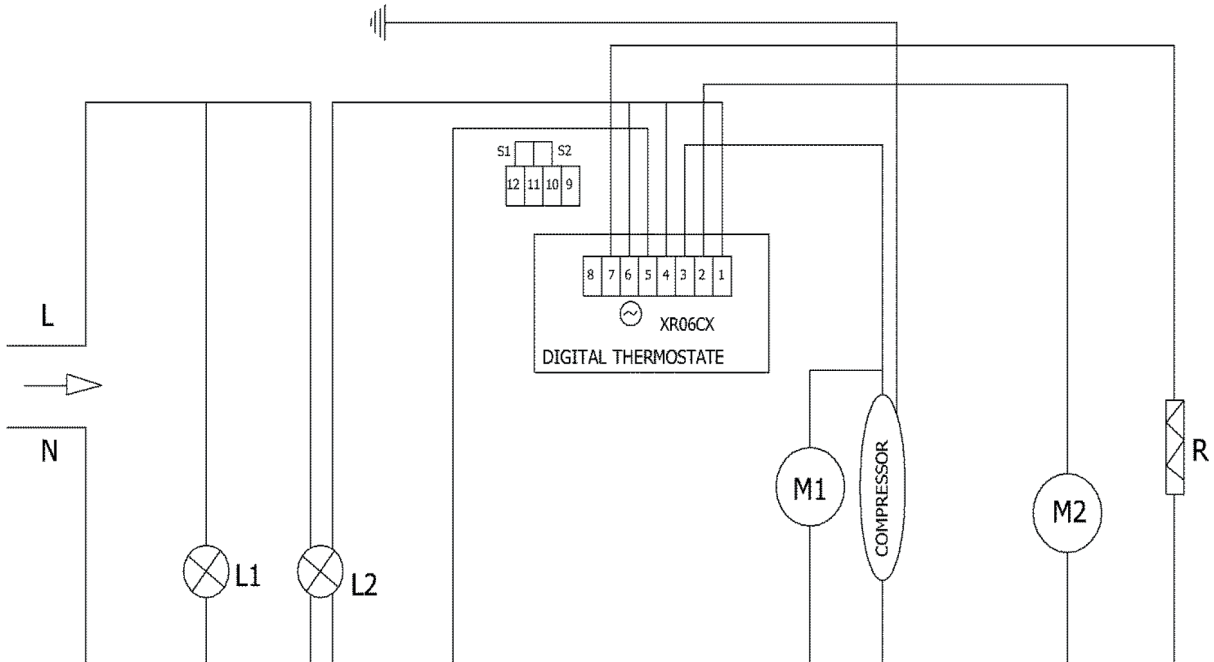

XR06CX : DIGITAL THERMOTER / DIJITAL TERMOSTAT
M1: KONDANSER FAN MOTORU / CONDENSER FAN MOTOR
M2 : EVAP FAN MOTOR / EVAP FAN MOTOR
S1 : ORTAM PROBU / ROOM PROB
S2 : EVAPARATÖR PROBU / EVAPORATE PROB

L1 : POWER LAMBASI / POWER LAMB
L2 : ACMA KAPAMA LAMBASI / ON OFF LIGHT
R: EVAPORATOR REZİSTANSI / EVAPORATE REZISTANCE