

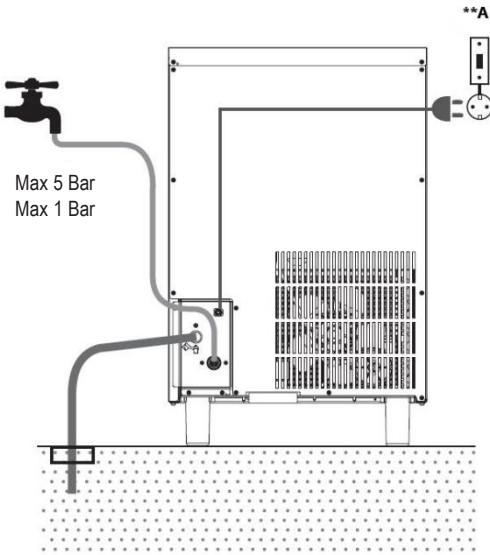

*Ice Makers
User Manual*

01



02

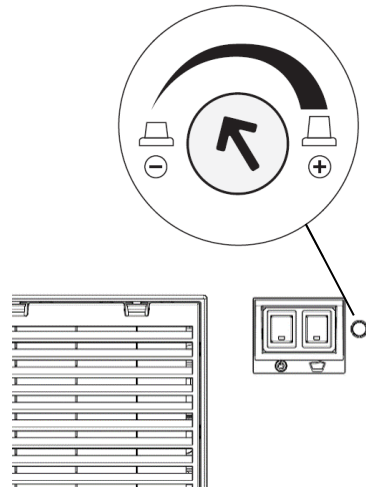

03

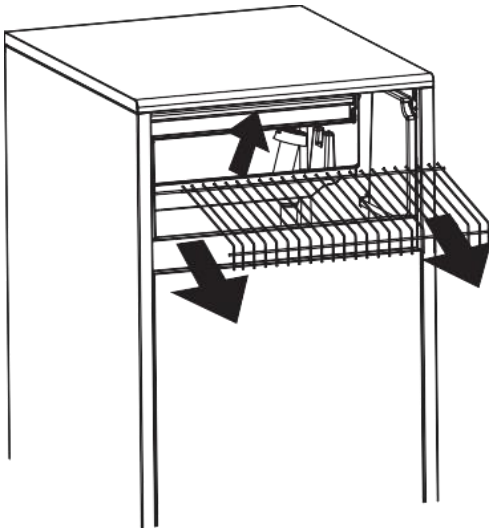

04

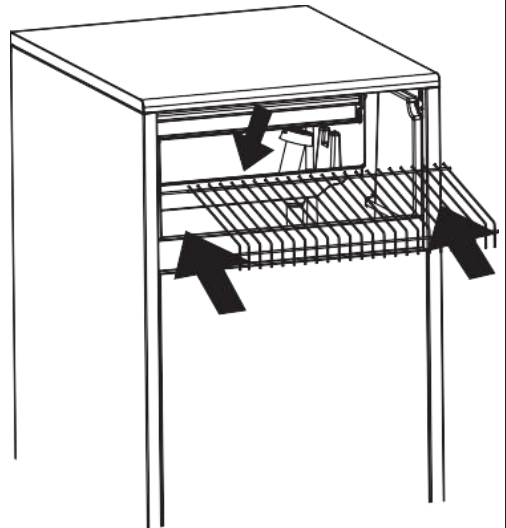

05



On-Off

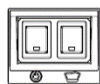

Ice Size Dim

Cleaning

06

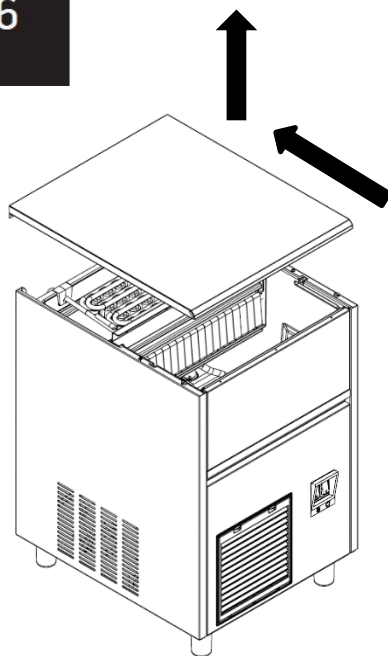

07

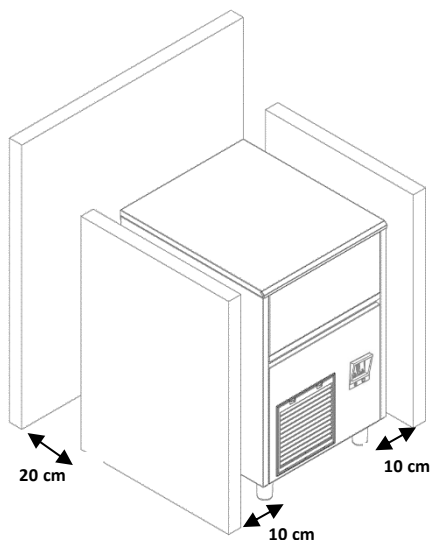

08

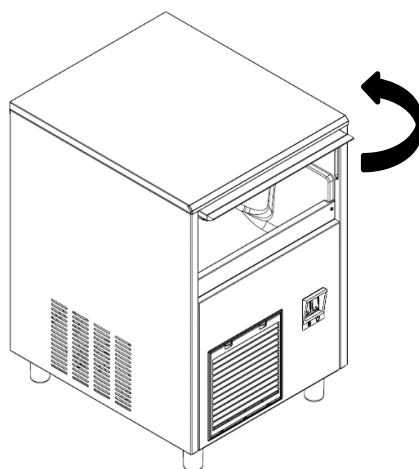

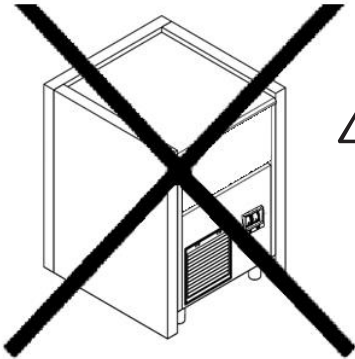

! **Location:** The ice machine must be located inside temperature controlled room. Running the ice machine outdoors or in an area that the temperature can go outside of the working limits may harm the machine, and your warranty may become void. Ice machines are designed and built with the highest respect for security.



! **Location:** In case the unit is located in an area with no side ventilation, ice maker does not work properly. Leaving enough room around the unit will allow the unit work properly. Normal ice-production capacity is directly relevant with the condenser air delta temperature, water temperature, states of the condenser air channel and age of the machine.

Dear Customer,

Your Ice-Maker was manufactured at the Eskişehir Facilities of

TASİS Makine Mühendislik Sanayi ve Ticaret A.Ş.

Please always have your Ice Maker installed by an Authorized Service.

Your manufacturer's warranty might become void in the case your Ice Maker has been installed by a third party service.

NOTE:

This User's Manual has been issued for several models.

Some features mentioned in this manual (indicated by *) may not be available on your product.

“READ THE INSTRUCTIONS BEFORE ASSEMBLING OR USING THIS ICE MAKER.”

This product has been manufactured in environment-friendly modern facilities without harming the environment

TABLE OF CONTENTS

Chapter 01..... Safety warnings

Chapter 02..... General Outlook and Technical Specifications

Chapter 03..... Installation of Your Ice Maker

Chapter 04..... Operating Instructions

Chapter 05..... Cleaning and Maintenance

Chapter 06..... Troubleshooting

Chapter 07..... Warranty Information

Chapter 01. Safety warnings

1. Always plug in your product to a grounded power outlet.
2. Your ice maker is designed to operate at voltage shown on Technical Table. Running the product at a different voltage may cause the product to become dysfunctional or even may cause fire.
3. Do not place your ice maker next to any heat source.
4. Set up your ice maker at a humidity-free location and with un-obstructed air circulation around the unit.
5. After the installation is done, do not move your ice maker and wait for at least two hours to start it.
6. Make sure you cleaned the inside surface of your product before first use.
7. Do not use power strips or extension cords to run your product.
8. Protect the power cord against hot surfaces.
9. Do not let un-trained and/or unsupervised children younger than 8 years old operate your ice maker.
10. The cleaning and maintenance of the device should not be made by children unless they are under supervision. (Whoever wrote this must have had a bad experience or trouble with children)

NOTE



This product bears (AEEE/WEEE) classification symbols indicating waste electric and electronic equipments. Accordingly, the user must comply with the European directive 2002/96/EC on recycling for the purpose of minimizing the impact of the waste product on the environment. It is recommended to communicate with local authorities about waste disposal.



Caution! This contains information necessary for prevention of serious hazards which may cause the product to become dysfunctional, or may cause injury or loss of life and property during the use of the product.



Warning against electric shock.



This indicates the explanatory and facilitating information related to use of the product.

Chapter 02. General Outlook and Technical Specifications

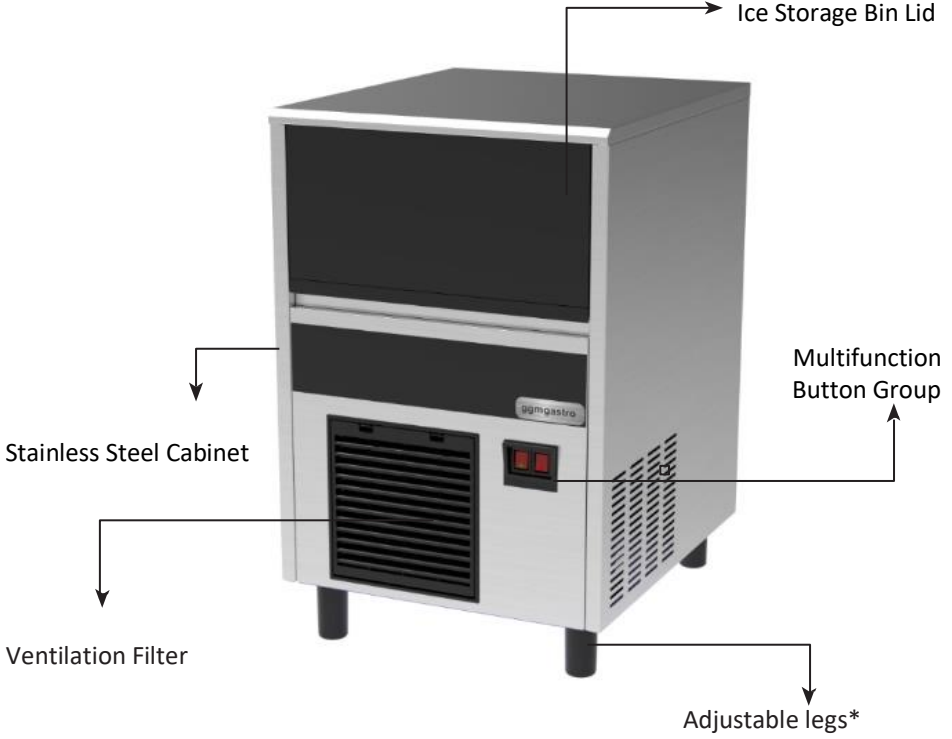

! Ürünlerde farklı görsel elde edilmesi, görüntüleme teknolojileri veya diğer teknik nedenlerden dolayı renk ve diğer çeşitlilikler açısından küçük farklılıklar görülmeye mümkündür. Üretici bu farklılıklar ve sapmalardan sorumlu değildir. Web sitesindeki yazım hataları, ürün açıklamaları veya belirgin hatalardan dolayı herhangi bir hak elde edilemez.

* Ayarlanabilir ayak ürün modellerine göre değişim gösterebilmektedir.

! Small differences in color and other variations are possible for different visualization, imaging technologies or other technical reasons. The manufacturer is not liable for these differences and deviations. No rights can be obtained due to typographical errors, product descriptions or obvious errors on the website.

* Adjustable legs can vary according to product models.

Technical Table

Product Code	EKZ22F	EKZ27F	EKZ32F	EKZ40F	EKZ47F	EKZ57F	EKZ67F	EKZ85F	EKZ96F
Refrigerant Gas	R290	R290	R290	R290	R290	R290	R290	R290	R290
Production Capacity (kg)	22	26	33	37	47	57	66	85	96
Storage Capacity (kg)	4	8	16	16	28	28	40	40	40
Ice Capacity Per Cycle (Unit)	18	18	28	36	44	44	60	60	68
Ice Type	Special Ice	Special Ice	Special Ice	Special Ice	Special Ice	Special Ice	Special Ice	Special Ice	Special Ice
Cooling System	Air	Air	Air	Air	Air	Air	Air	Air	Air
Climate Class	T	T	T	T	T	T	T	T	T
Voltage	230V-50Hz 115V-60Hz	230V-50Hz 115V-60Hz	230V-50Hz 115V-60Hz	230V-50Hz 115V-60Hz	230V-50Hz 115V-60Hz	230V-50Hz 115V-60Hz	230V-50Hz 115V-60Hz	230V-50Hz 115V-60Hz	230V-50Hz 115V-60Hz
Maximum Power	300 W	350 W	470 W	520 W	550 W	550 W	780 W	1000 W	1100 W
Daily Electric Consumption	5,1 kW	5,9 kW	8,5 kW	10,4 kW	12,6 kW	14,7 kW	16,1 kW	16,4 kW	17 kW
Fuse **	10 A	10 A	10 A	10 A	10 A	10 A	16 A	16 A	16 A
Product Weight (kg)	26	30	38	39	45	48	75	85	88
Product Dimension (w*d*h)	355*435*590	390*515*640	500*580*690	500*580*690	500*580*800	500*580*800	738*600*822	738*600*822	738*600*822
Packing Dimension (w*d*h)	415*495*765	450*575*710	555*635*855	555*635*855	555*635*965	555*635*965	800*660*1000	800*660*1000	800*660*1000
Loading Quantities (20DC)	210	168	72	72	72	72	46	46	46
Loading Quantities (40HC)	420	368	216	216	144	144	102	102	102
Loading Quantities (Tr.-Optima)	480	405	279	279	186	186	120	120	120

(*) Indicates the daily ice making capacity of the product at 20 °C Ambient and 10 °C Water Inlet temperature.

(**) Check the values of the electrical network to which the product is connected.



The presence of particles in the water due to quality of the water supply and / or contamination with dirt, installation residue, burrs, slag and so on will adversely affect the operation of the ice maker. Such contamination may cause inefficient operation, no ice making, loud noises, etc. Problems with the machine due to plumbing and/or calcified water are not covered by the warranty.

Chapter 03. Installation of Ice Maker

Selection of Location for Your Product

- ① Your product should not be in direct contact with or in close proximity to any heat source.
- You should leave at least 10 cm of distance if you place your ice maker next to other electrical equipment (such as ovens, computers etc.) that are considered as heat sources.
- If the product is to be placed next to a wall, the distance between the back surface of the product and the wall should not be less than 20 cm (See Figure-7).
- Do not place objects in front of the ventilation filter of your ice maker that might prevent air circulation into your product.
- Do not place your product outdoors. This product is designed to be used indoors.

Electrical Connection

- The voltage and frequency values of the main power supply have to be the same as written on the product label. If you are in doubt or need assistance, please contact the nearest Authorized Service or get help from a qualified electrician.
- ⚡ Make sure your power outlet has been grounded.
- ⚡ The amperage of the circuit breaker to which the product will be plugged in should be 10A**. (See Technical Table / Entry fuse section.)
- ⚡ Do not use power strips with multi sockets or extension cords to operate your product.

Water Use and Connection

Your ice maker is designed to make ice cubes within the most ideal time and size. However, it is important to note that there are some things that will affect the quality of the ice produced by the machine, as well as the health of the internal components of the ice maker.

The Water Supply

- ① Should be good for human consumption,
 - ① Should have an optimum level of hardness,
 - ① Should include minimal amount of chlorine.
- ⚠ The optimum water filters to be used on your product are available and can be purchased from your Authorized Service.
Water temperature should be between 10°C and 30°C

Installation

- Remove and disassemble all packaging materials of the product before installation.
- The ice slide grate, waterproofing plastics and the ice scoop are provided inside the product. If any part or accessory is missing, please contact our customer services.
- Clean the inner cabinet with warm water and a soft cloth before using the ice maker. Clean the ice trays with warm soapy water. Dry with a soft, cotton cloth. After placing the ice maker at the installation point, wait 2 (two) hours before operating to get the cooling system pressure stabilized. Install the parts inside the ice maker in accordance with the assembly instructions.
- The cold water inlet pressure must not exceed the operating water pressure (5 Bar) indicated on the technical data sheet. If the line pressure is higher than 5 Bar, a pressure reducer must be installed.
- Connect your device to the mono phase - grounded power supply of the rating indicated on the nameplate. Your device is designed to function normally within $\pm 10\%$ of the main voltage. If this range cannot be provided in your local power network, it is recommended to use a voltage regulator.
- If it is necessary to change the location of your ice maker, be sure to transport the unit according to the markings on the original packaging of the device.
- Protect your device against factors that may damage the package and the device (moisture, water, impact, chemical, etc.).
- Only Authorized Service should disassemble the device. Never interfere with the internal parts and elements of the ice-maker.
- The device must be commissioned by the Authorized Service.
- Failure to comply with the above conditions will void your product warranty.
- Do not leave packaging materials (plastic bags, nylon, etc.) within the reach of children.
- The manufacturer reserves the right to change the information in this manual. Therefore; this booklet does not constitute a commitment to specifications.

Chapter 04. Use of the Ice Maker

Operating the Ice Maker

After installing your Ice Maker following the instructions above and making all necessary connections;

1. Make sure that the power outlet you are using for your ice-maker is live and has power.
2. Turn on the water.
3. Set the On-Off button at the front of your product to the On position. (When you set it to the On position, the power light on the button will turn on.)
4. The product will automatically go into a delay-time mode for 1 minute after it is turned on.
5. At the end of the delay-time mode, the product will start getting water and making ice.
6. Your product will complete the ice-making cycle after a certain time, depending on the ambient and water temperature.
7. To change the dimple size of the ice made by the ice maker, adjust the potentiometer in the direction of the arrow. (See Figure-2).



NOTE

In order to allow your product to make ice in the optimum dimple size and-time, you need to wait for at least 2 hours after the installation, before turning on the machine.

Shutting Off The Ice Maker



Set the power button at the front of your Ice Maker to “Off” position.



Unplug the product if you are not going to use the ice-maker for a long time.



Turn off the water.

There are some malfunction and warning signals defined for the Red light on the power button of the product as detailed in the chart below.

Function Mode	On	Off
Cleaning	3 sec	1 sec
Fault	2 sec	2 sec
Ice Bin Full	1 sec	1 sec

Chapter 05. Cleaning and Maintenance of Your Ice Maker



Safety rules must be observed before cleaning your Ice Maker:

1. Unless otherwise specified, turn off and unplug the unit before starting to clean the Ice Maker.
2. The outer cabinet of the product should only be cleaned by wiping with a damp cloth. Do not spray the unit with water or any other cleaning solvent. This causes undesired electrical failures and jeopardizes the safety of the user.
3. Always wear protective gloves and similar protective equipment during cleaning.
4. Never use cleaning agents and chemicals which may cause cutting, piercing and corrosion to your product. Your Ice Maker will be out of warranty if chemicals are used for cleaning.
5. Do not use any cleaning agents not recommended by your Authorized Service.



Exterior Cleaning of the Ice Maker



The exterior of your ice-maker is made of stainless steel. Wipe the exterior surfaces with a cotton damp cloth or a sponge and then wipe it with a dry, clean cotton cloth.

Cleaning of the Sprayer System

1. Make sure the water and electrical connections of the product are off, in compliance with the cleaning instructions above.
2. Remove all the ice from the storage bin.
3. The power switch should be off, and the water inlet valve should be opened.
4. Remove the slide grate located inside the inner basin and then remove the level discharge plastic from its slot, and ensure the water to be discharged. (See Figure-3)
5. Place the water level drain plastic group back to its slot after discharging the water inside the pool. (See Figure-4)
6. Then, pour the cleaning solution recommended by Authorized Service into the water pool.
7. Select the 'cleaning' setting on your product, then turn the power switch to the "On" position. WITHIN 30 SEC OF TURNING ON THE POWER, YOU MUST PRESS AND HOLD THE 'CLEANING' BUTTON FOR 9 SEC. (See Figure-5)
8. The cleaning process will continue for 10 minutes.
9. At the end of the cleaning cycle, remove all the produced ice from storage bin.

-  Do not turn off the product while cleaning is in progress.
After the cleaning process, discharge the water inside the inner basin. (See figure 3)
-  Right after this cleaning, the Ice Set must be cleaned.

Cleaning of the Ice Set

To remove the top cover, remove the screws in “Figure-6”. Remove the plastic cover on the cooling pipes. Clean the cooling pipes and visible surfaces in the tank with cleaning solution / soapy cloth. Then rinse and then dry. Close the plastic cover that protects the cooling system pipes and then close the top cover of the product. Then replace the screws.

Cleaning of the Ice Storage Bin

1. To clean the ice bin, first turn the power switch to the “Off” position. Then disconnect the product from the main power supply.
2. Drain the ice completely from the ice bin.
3. Wipe the inside of the ice bin with cleaning solution / soapy cloth and then rinse / dry.
4. Take care not to allow any lime and/or cleaning solution residue to remain.

Cleaning of the Water Inlet Filter

1. Disconnect the Ice Maker from main power supply.
2. Disconnect the water connection of your ice maker.
3. Remove the water inlet filter. (The frequency of cartridge replacement varies depending on the usage period, but it is recommended to change every 6 months.)
4. Follow the filter manufacturer's maintenance and cleaning instructions / recommendations to perform cleaning and maintenance of the water inlet filter.

 Then return the Ice Maker to operation by following the installation instructions.

 The applications specified in the product cleaning instructions should be performed at least 4-5 times a year.

Chapter 06. Actions to be Taken Before Calling Authorized Service

Malfunction	Probable Reason	Solution
Ice Maker does not work	Power button is Off.	Set the power button to the “On” position.
	The power connection is faulty.	Get the power connection checked by a qualified electrician.
	The Ice Maker is in protection mode.	Check the place selection instructions of the ice maker. Ice Maker does not receive adequate amount of air.
	No power in the outlet.	Check the fuse connected to the outlet.
The compressor stops shortly after it starts working	Ambient temperature is very high	Check the place selection instructions of the ice maker. Ice Maker does not receive adequate amount of air. Clean the ventilation filter.
	Grid voltage is low	Get the power connection checked by a qualified electrician.
Ice Set is cooled but the water inside the water pool is insufficient	Water valve is faulty	Contact the nearest Authorized Service.
	Water supply pressure is low	Make sure that the water supply pressure is greater than 1 Bar.
	Water level drain plastic group seeps	Place the water level plastic group to its slot tightly.
Ices are not transparent	Water nozzle is blocked	Water nozzle sprayer should be checked. The blocked nozzles should be cleaned.
	Water pool is dirty	Clean the Ice Maker by following the cleaning instructions.
	Pressure of the water pump is low	Contact the nearest Authorized Service.
	The water is blurry / dirty / chlorinated	Use a water filter.

Malfunction	Probable Reason	Solution
Ices are much smaller than they should be.	Water is insufficient	Place the water level plastic group to its slot tightly.
	Cooling system is faulty	Check the water main connection for the water leakage. Contact the nearest Authorized Service.
Ices are much bigger than they should be.	Time setting is incorrect	Set the time on the electronic card to a lower value.
	Sensor is faulty	Contact the nearest Authorized Service.
The quantity of the ice is insufficient	Gas leakage in the defrost solenoid	Contact the nearest Authorized Service.
	Water valve is faulty	Contact the nearest Authorized Service.
Device does not stop when the ice bin is full	Sensor is faulty	Contact the nearest Authorized Service.

Chapter 07. Scope of Warranty

Dear Customer,

This warranty provided by our company does not cover the repair of defects caused by unusual use of the ice maker, and the following items are excluded from the warranty.

- Malfunctions and damages caused by the operator during use,
- Malfunctions and damages that occurred during shipment or during loading or unloading and during delivery to the end-user,
- Malfunctions and damages that occurred due to low or high voltage, usage contrary to the voltage written on the label of the product and the electrical installation,
- Malfunctions and damages that occurred after any fire or lightning during use,
- Malfunctions resulting from use of the product contrary to the warnings and methods specified in the user manual,

 The repairing of the above-mentioned malfunctions shall not be included in the scope of the warranty, the repair shall be charged.

 The shipment to the place of use and the assembly of the product are excluded from the product price.

 The responsibility for confirming and granting Warranty Certificate to the consumer shall belong to the seller, reseller, agency or representation from which the consumer bought the good.

 The warranty is valid for the period mentioned in the warranty certificate and only for the malfunctions that occurred in the product; no other claims, for a refund, repair or replacement shall be done. In the case that any destruction/falsification of the original serial number recorded on the warranty certificate and on the product is found, the product shall be out of warranty. As for the repairs within the scope of the warranty, only the services specified in the warranty certificate or on our website are authorized.

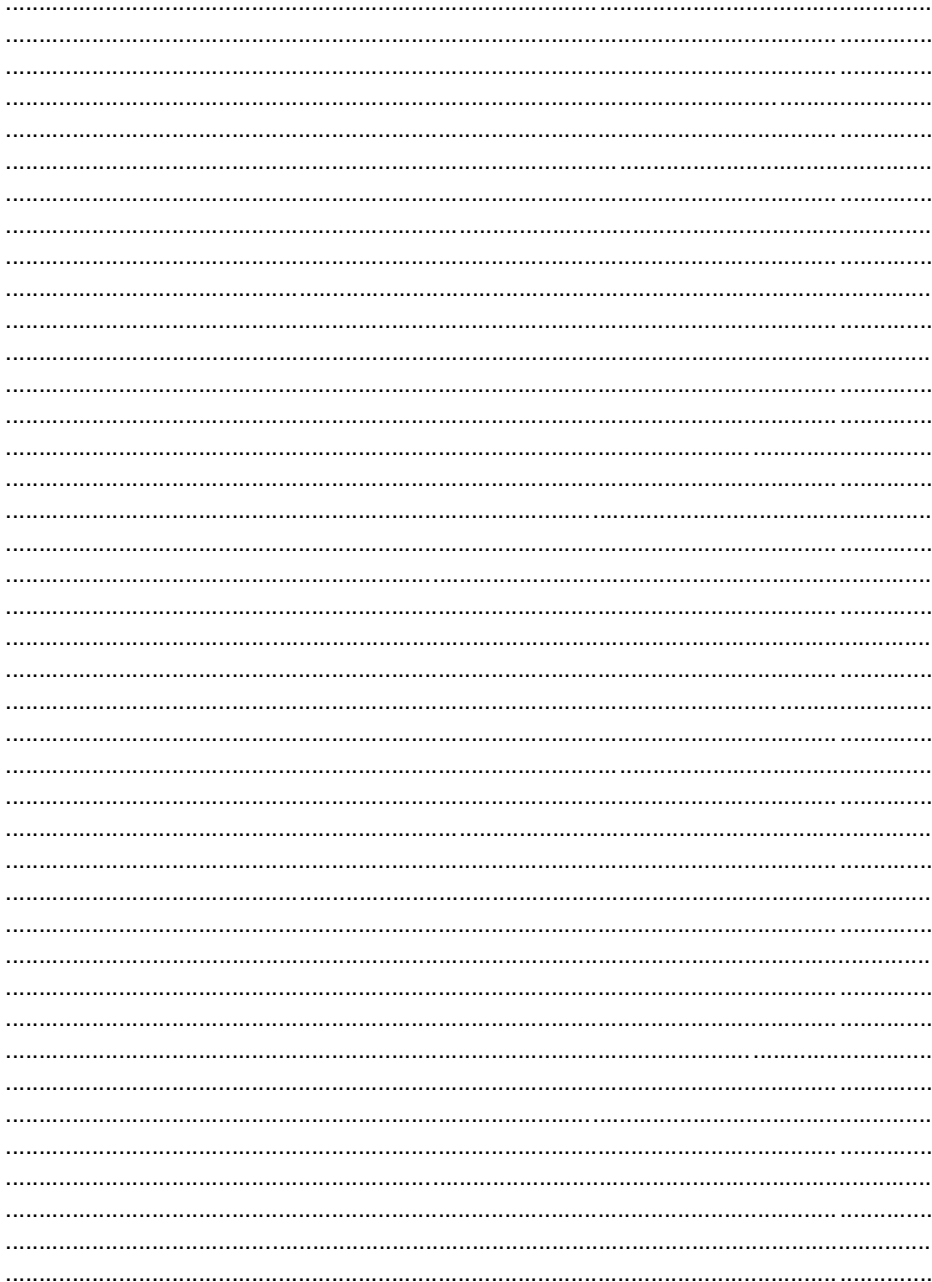

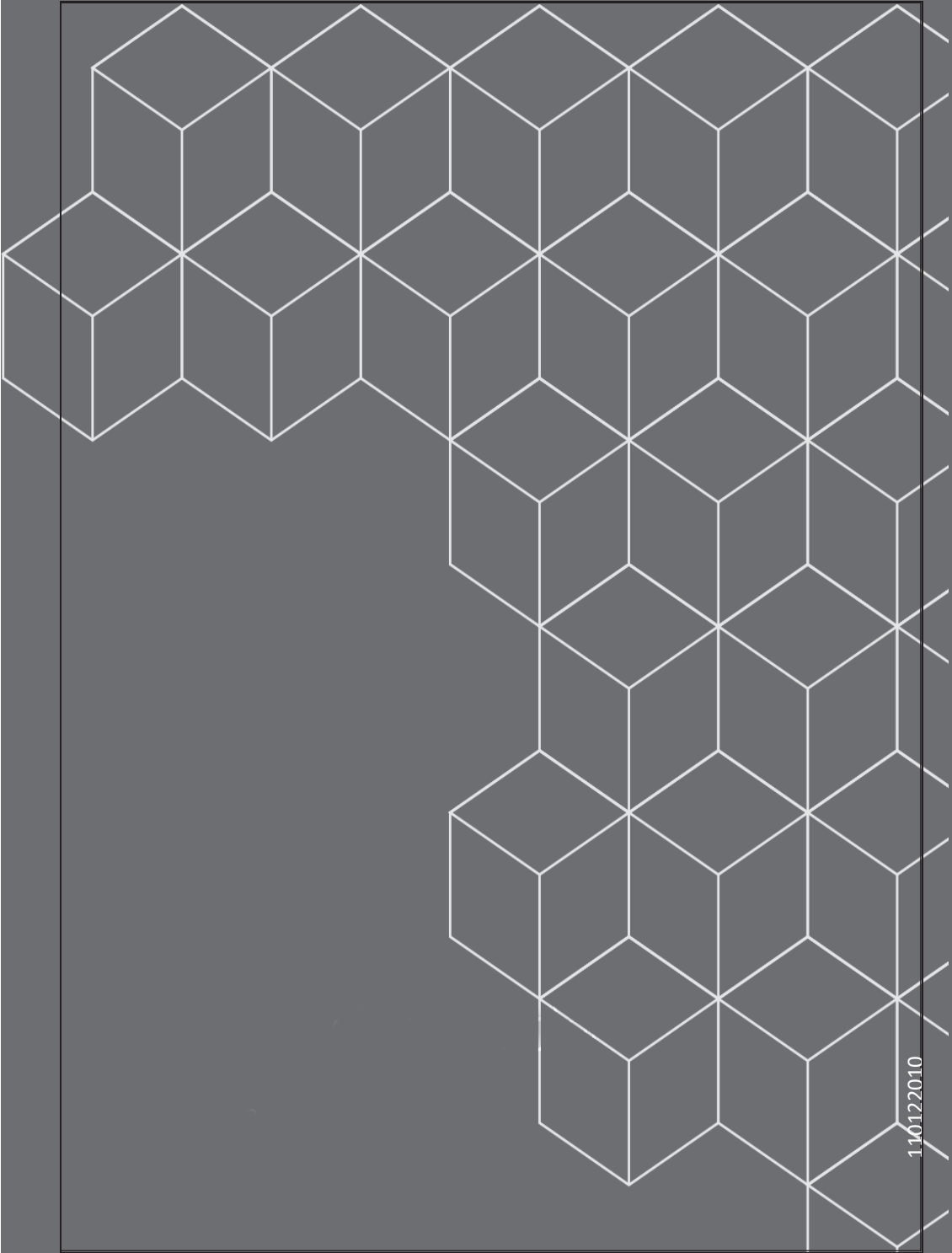

110122010