

CABINET

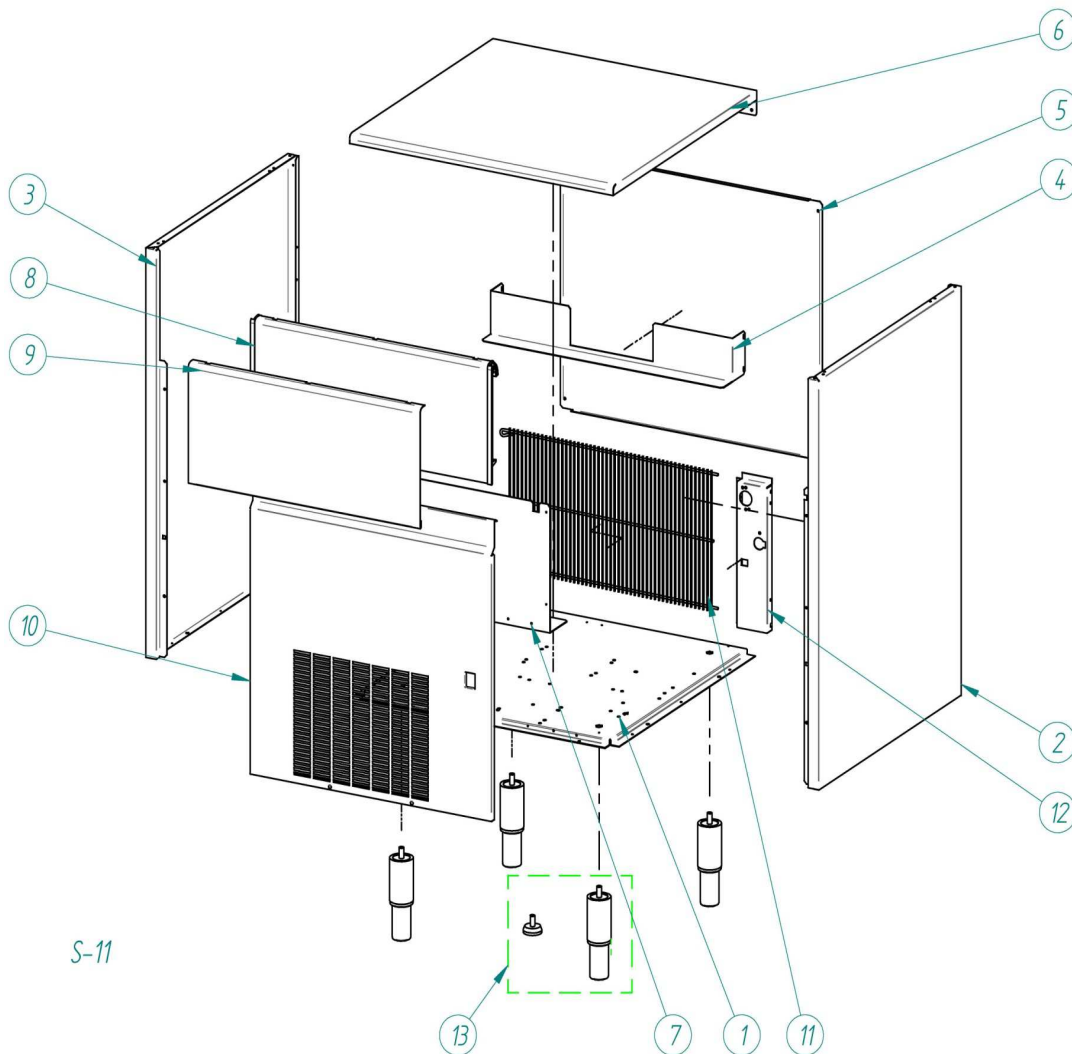

CABINET	
	NAME
1	BASE
2	RIGHT PANEL Versión SS
	RIGHT PANEL Versión SP (SL)
3	LEFT PANEL Versión SS
	LEFT PANEL Versión SP (SL)
4	REAR SUPPORT
5	REAR PANEL
6	TOP PANEL Versión SS
	TOP PANEL Versión SP (SL)
7	FRONT SUPPORT
8	DOOR
9	TOP PANEL (DOOR) Versión SS
	TOP PANEL (DOOR) Versión SP (SL)
10	FRONT PANEL AND GRILL SS
	FRONT PANEL AND GRILL SP (SL)
11	REAR GRILL
12	TUBE SUPPORT
13	LEGS

STOCK BIN

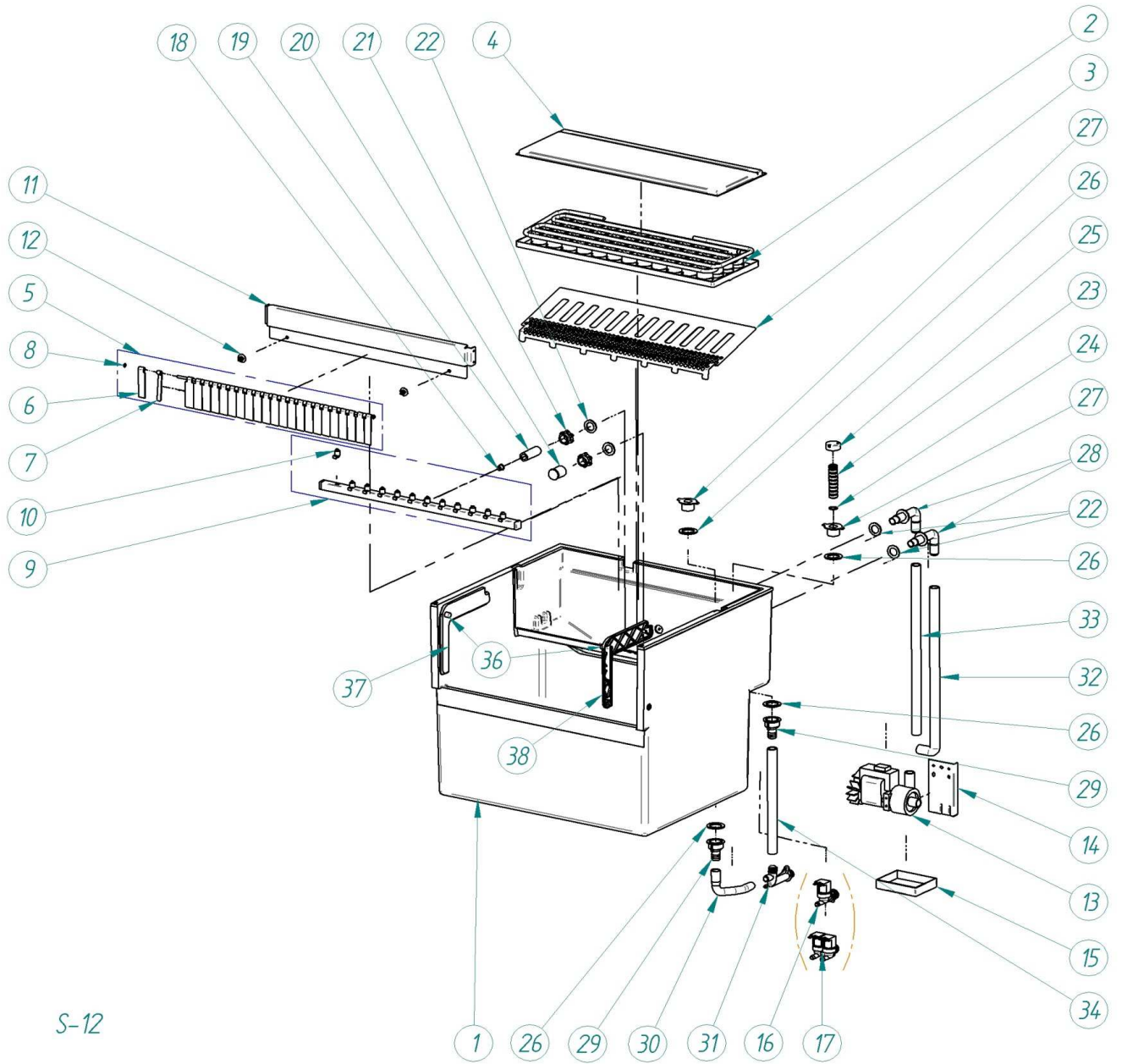

S-12

STOCK BIN

WATER BIN	
	NAME
1	STOCK BIN
2	EVAPORATOR 30gr
	40gr
3	EJECT CUBE GRILL
4	TAPA EVAPORADOR
5	CURTAIN
6	EXTERIOR CURTAIN LAUVRE
7	INTERIOR CURTAIN LAUVRE
8	JOINT
9	COLECTOR
10	NOZZLE
11	CURTAIN SUPPORT
12	CLIP
13	PUMP
14	PUMP SUPPORT
15	BANDEJA CONDENS
16	WATER INLET VALVE
17	WATER INLET VALVE
18	WATER REGULATOR
19	TUBE
20	FILTER
21	PLASTIC NUT
22	JOINT
23	OVERFLOW PLASTIC COUPLING
24	OVERFLOW TUBE
25	ELBOW ADAPTER
26	JOINT
27	DRAIN
28	DRAIN ELBOW ADAPTER
29	DRAIN STRIGHT UNION
30	DRAIN COUPLING
31	WATER DISTRIBUTOR
32	WATER INLET TUBE
33	WATER OUTLET PIPE
34	MANGUITO REBOSADERO
36	CLIP
37	LEFT GUIDE
38	RIGHT GUIDE

AIR UNIT CONDENSER

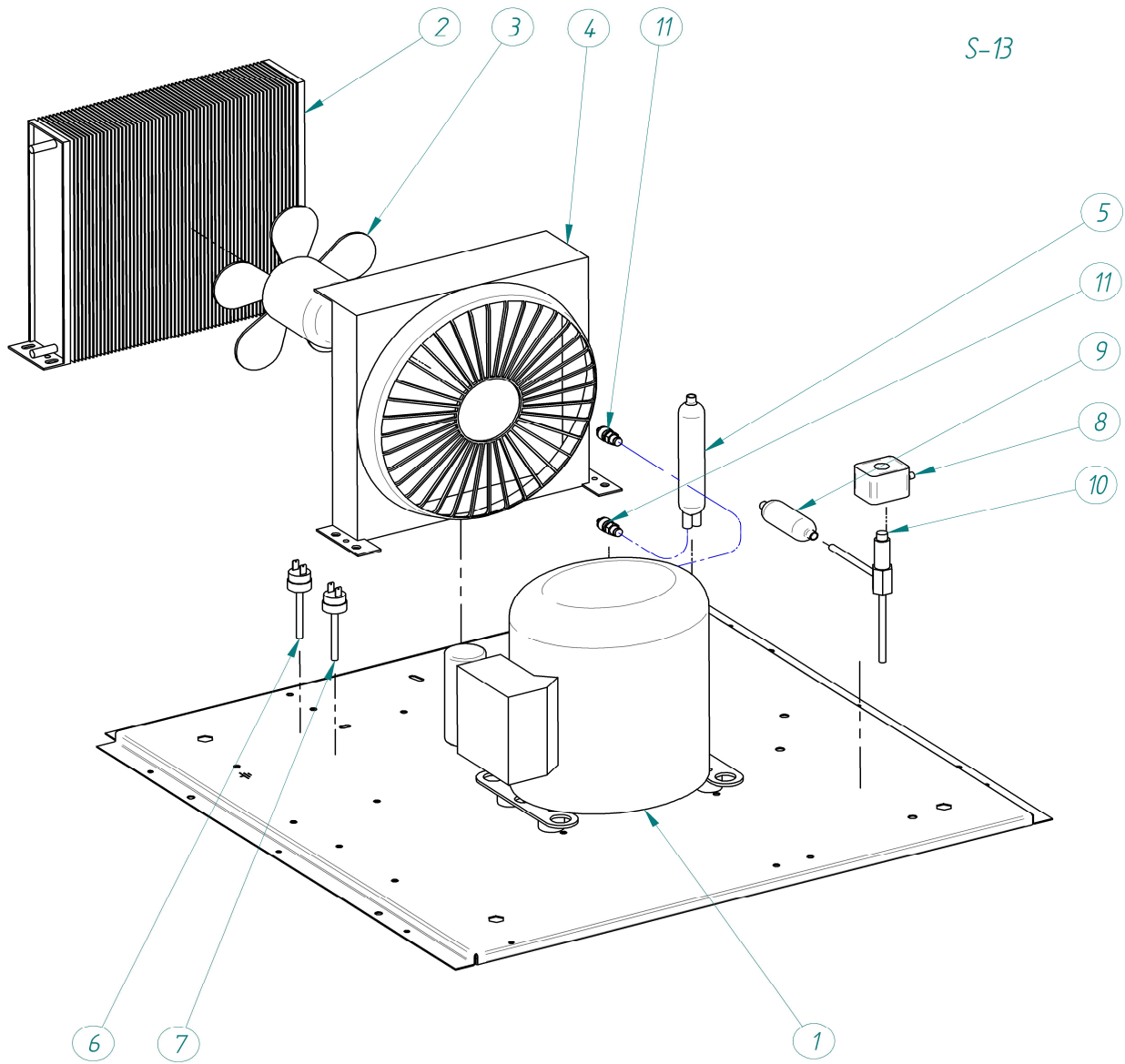

UNIT CONDENSER	
	DENOMINACION
1	COMPRESSOR
2	CONDENSER
3	FAN
4	BAFLE
5	DRIER
6	SAFETY PRESOSTAT
7	CONDENS PRESOSTAT
8	COIL
9	FILTER
10	HOT GAS VALVE
11	INLET VALVE

WATER UNIT CONDENSER

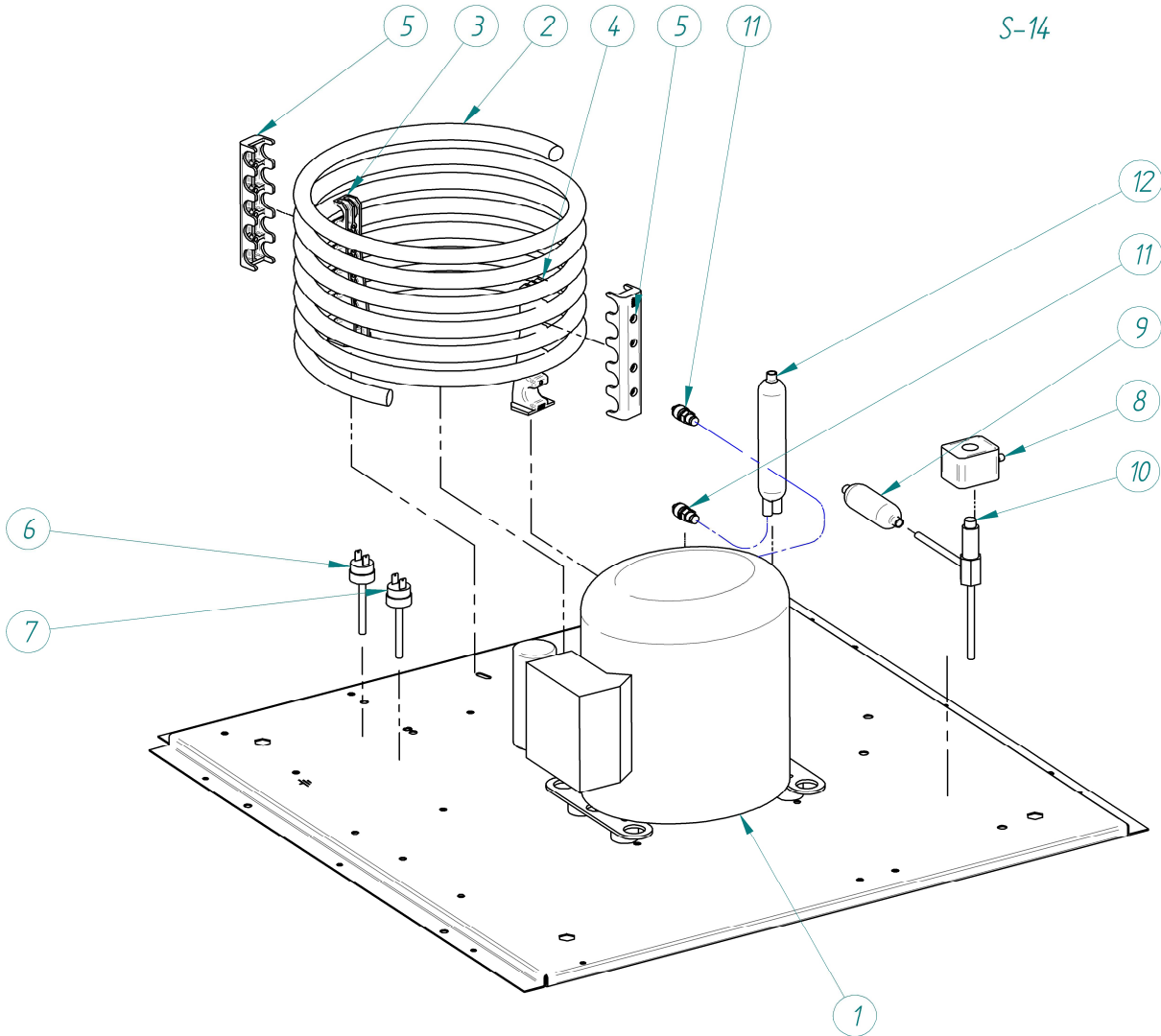

WATER UNIT CONDENSER	
NAME	
1	COMPRESSOR
2	CONDENSER
3	SUPPORT
4	SUPPORT
5	SUPPORT
6	SAFETY PRESOSTAT
7	CONDENS PREOSTAT
8	COIL
9	FILTER
10	HOT GAS VALVE
11	VALVE REFRIG REFILL
12	DRIER

ELECTRIC BOARD

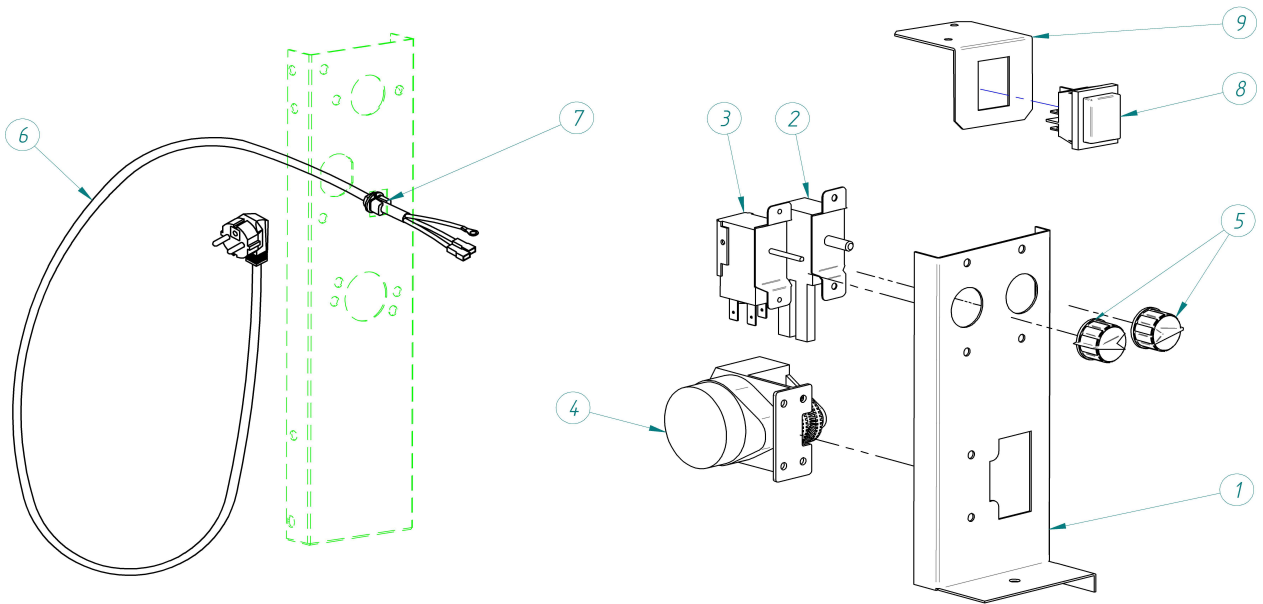

S-15

ELECTRIC BOARD

ELECTRIC BOARD	
NAME	
1	SUPPORT
2	CYCLE THERMOSTAT
3	STOCK THERMOSTAT
4	TIMER
5	THERMOSTAT CONTROL
6	ELECTRIC CORD
7	WIRING FIXING FLANGE
8	INTERRUPTOR
9	SOPORTE INTRRUPTOR