

CABINET

EXPLODED VIEWS

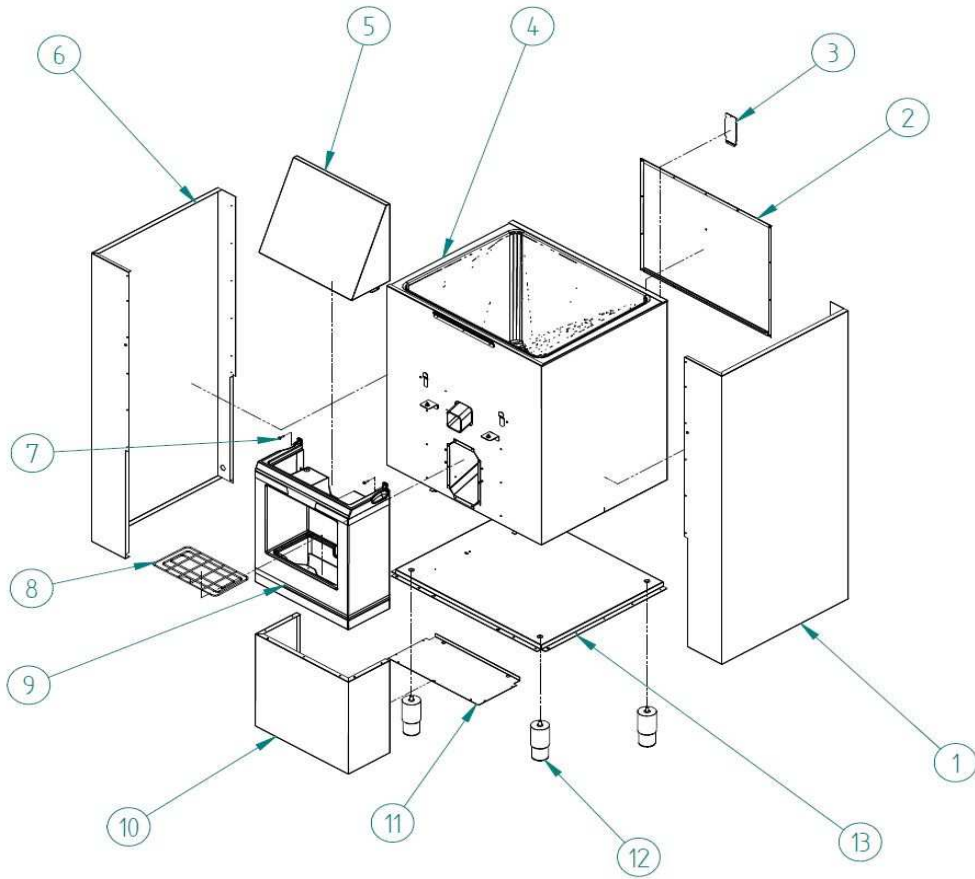

NAME	
1	RIGHT PANEL
2	BACK PANEL
3	TOP COVER
4	INSULATED BIN
5	TOP FRONT
6	LEFT PANEL
7	SCREW M5x20
8	GRILL
9	FRONT
10	LOWER FRONT PANEL
11	BASE
12	INOX LEG
13	BASE

DISPENSER PARTS

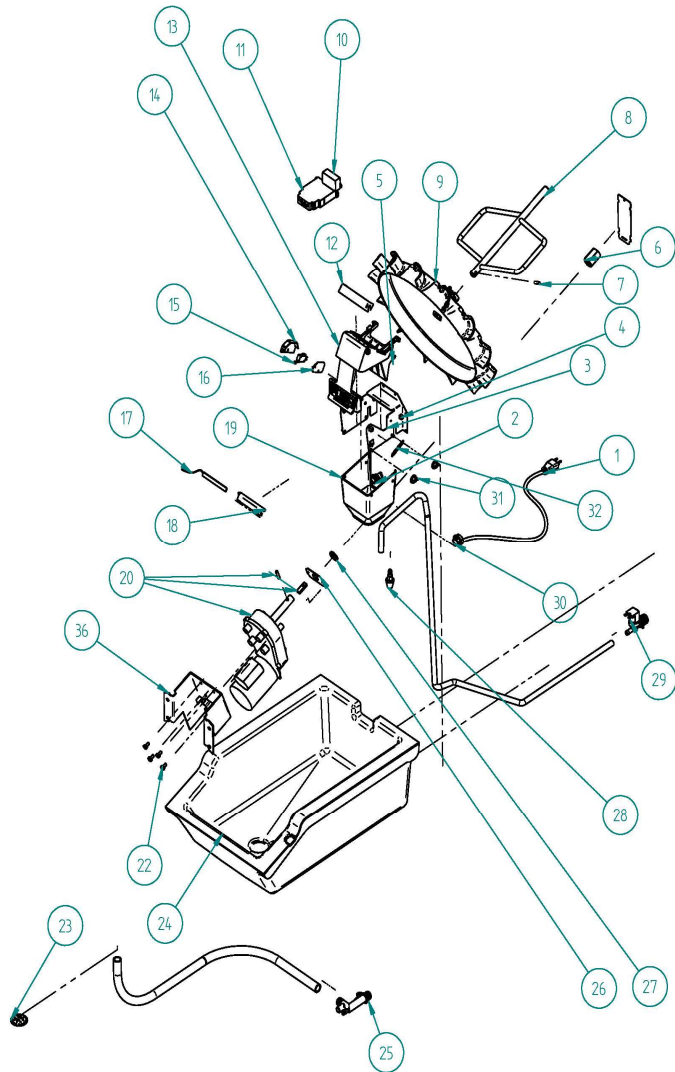

	NAME	
1	SCHUCKO PLUG	220V
		110V
2	PUSH-BUTTON	
3	MECHANISM SUPPORT	
4	BUSHING	
5	COVER	
6	BUSHING	
7	SHAFT HASP	
8	SHAKER	
9	WHEEL	
10	FEEDER LED	
11	TIMER	
12	TENSE	
13	ICE PUSH-BUTTON	
14	MICRO BOX	
15	MICRO	
16	PROTECTION (MICRO)	
17	LED	
18	LED SUPPORT	
19	ICE EXIT	
20	MOTOR	220V
		110V
22	SCREW	
23	DRAIN GIRLL	
24	DRAIN BIN	
25	WATER DISTRIBUTOR	
26	SEAL COVER	
27	SEAL	
28	WATER EXIT	
29	WATER VALVE	220V
		110V
30	WIRING FIXING FLANGE	
31	NUT	
32	SPRING	
32	MOTOR BRACKET V2 3MM	