

**KTF226-EF**

**DATEI MIT MATERIAL UND TECHNISCHEN SPEZIFIKATIONEN**

**MATERIAL AND TECHNICAL CHARACTERISTICS MANUEL**

**INHALT / INDEX :**

- 1. EIGENSCHAFTEN / CHARACTERISTICS**
- 2. INNERE UND ÄUSSERE ABMESSUNGEN / INSIDE , OUTSIDE DIMENSIONS**
- 3. EXPLOSIONSBILDER / EXPLODED VIEW**
- 4. ERSATZTEILLISTE / SPARE PART LIST**
- 5. GAS- UND STROMREGELUNG / GAS AND ELECTRICAL SCHEMA**

**KTF226-EF**



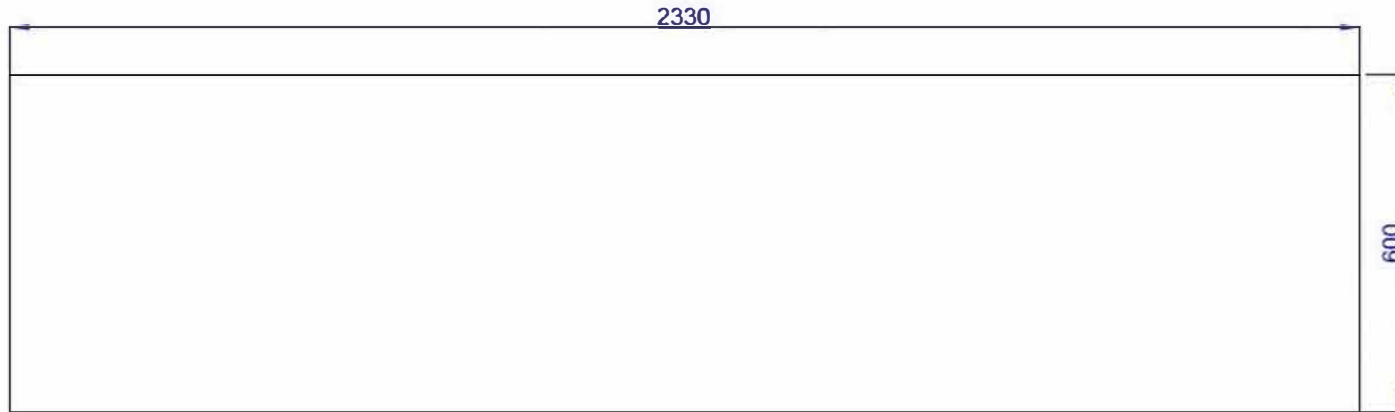
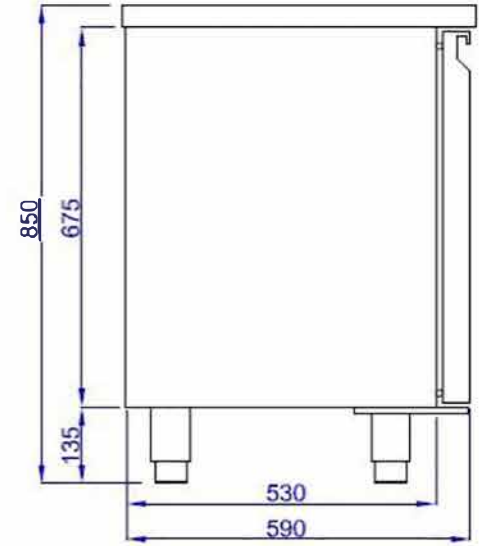
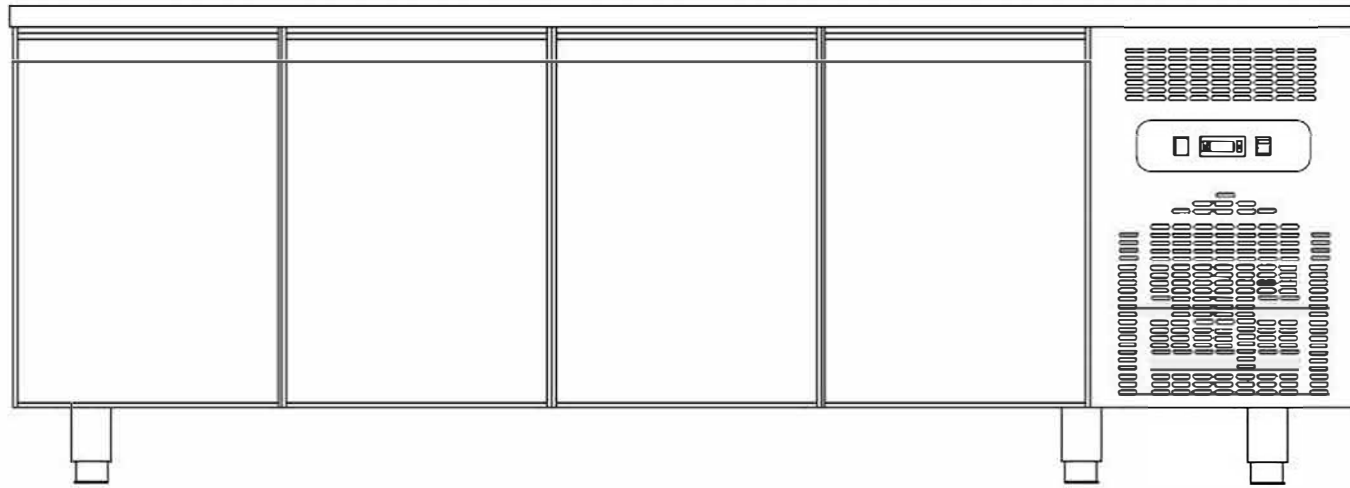

AUSSENMASSE / OUTSIDE DIMENSIONS = 2330x600x850

INNENABMESSUNGEN / IN SIDE DIMENSIONS = 1760x462x605

**ggmgastro**  
INTERNATIONAL

**KTF226-EF**

VERBODEN TOEGANG DEGERLERE 729-73 30.10

U.M. Ölçök  
mm 1:1



REV.N° :

## KTF226-EF CHARAKTERISTISCHE MERKMALE KTF226-EF CHARACTERISTIC SPECIALITIES

Klima-Klasse / Climate Class	:B
Sicherheitsklasse / Safety Class	:1
Betriebstemperatur / Working Tempature C	:-2C / +8C
Thermoster Einstelltemperatur / Thermostate Set Tempature	:-1C
Temperatur in der Umgebung / Environment Tempature	:+43C
Luftfeuchtigkeit der Umgebung / Environment Moisture Propertion	:%65
Energieverbrauch / Energy Consuption	:0,45 KW/H
Strom / Power	:0,35 KW
Spannung - Frequenz / Voltage- Frekans	:240V / 50 Hz

### ZUBEHÖR UND KONTROLLLEUCHTEN / ACCESORIES AND CONTROL SWITCHES

Digitaler Thermostat / Digital Thermometer	: Digital Thermometer
Energie Lampe / Energy Lamp	: Ad / PCC1
Ein/Aus-Schalter / Power Switch	: Ad / PCS1
Scharnier-Gruppe / Hinges Group	: Ad / PCS4
Stand / Stand	: Ad/PCS 6 Beizmittel Stahlständer / + stainlies Steel Stand
Regal /Shelf	:4Ad.Kunststoffbeschichtetes Regal/4 Unts Plastic Coated Shelf

### TECHNISCHE DATEN / TECHNICAL CHARACTERISTICS

Äußere Abmessungen / Outside Dimensions	:2330x600x850mm
Innere Abmessungen / Inside Dimensions	:1760x462x605mm
Verpackung Abmessungen / Package Dimensions	:2430x700x1000mm
Internes Volumen / Inside Volume	: 550 lt
Bruttogewicht / Gross Weight	: 200 kg
Nettogewicht / Net Weigt	: 180 kg
Äußerer Körper / Outside Body	: 0,60 mm INOX 430 SB+PVC
Innerer Körper / Inside Body	: 0,50 mm INOX 430 MAT+PVC
Dämmstoffdicke / Insulation Metarial Thicnes	: 50 mm
Dichte des Isoliermaterials / Insulation Metarial Volume	: 42 Kg / m3 +/-1
Kompressor / Compresor	: EMC 3134 U R290 KOMPRESÖR
Verflüssiger / Condanser	: 1/2 Hp Verflüssiger mit Haube-R290
Verflüssiger-Lüfter / Condanser Fan	: ECM7112 ENERGY SAVING FAN
Verdampfer / Evaporatör	: NTV tip evap / NTV type evap(0,20kw) x 2 Stücke
Verdampferlüfter / Evaporatör Fan	: ACC-RJL1238B2-3 ENERY SAVING QUADRATFAN
Trockner-Filter / Dryer	: 30 gr 15002SGDR02 Doppelter Eingang
Kältemittel Gas / refrigerator Gas	: R290
Kältemittelmenge / Ref. Gas Quantity	: 85 gr
Zulassungen / Certifications	: Entspricht der TS 2225 EN 60335-2-4.
Seriennummer. / Serial No	: Sie ist an einer geeigneten Stelle geschrieben, um in verpackter Form gelesen zu werden / Packed And Easy Read
Verpackung / Packing	: Alta Holzpalette, Karton und Luftnylon im Inneren / Wooden Palet Is Down And Covered
Gewährleistungsfrist / Qualty Time	: 2 Jahre gegen Herstellungsfehler ab dem Zeitpunkt der Verwendung. Garantiezertifikat und Liste der autorisierten Servicestellen sind mit jedem Produkt erhältlich. / 2 Years After arriving the end user point. Warranty Certicate and User Manuel With the Unit.

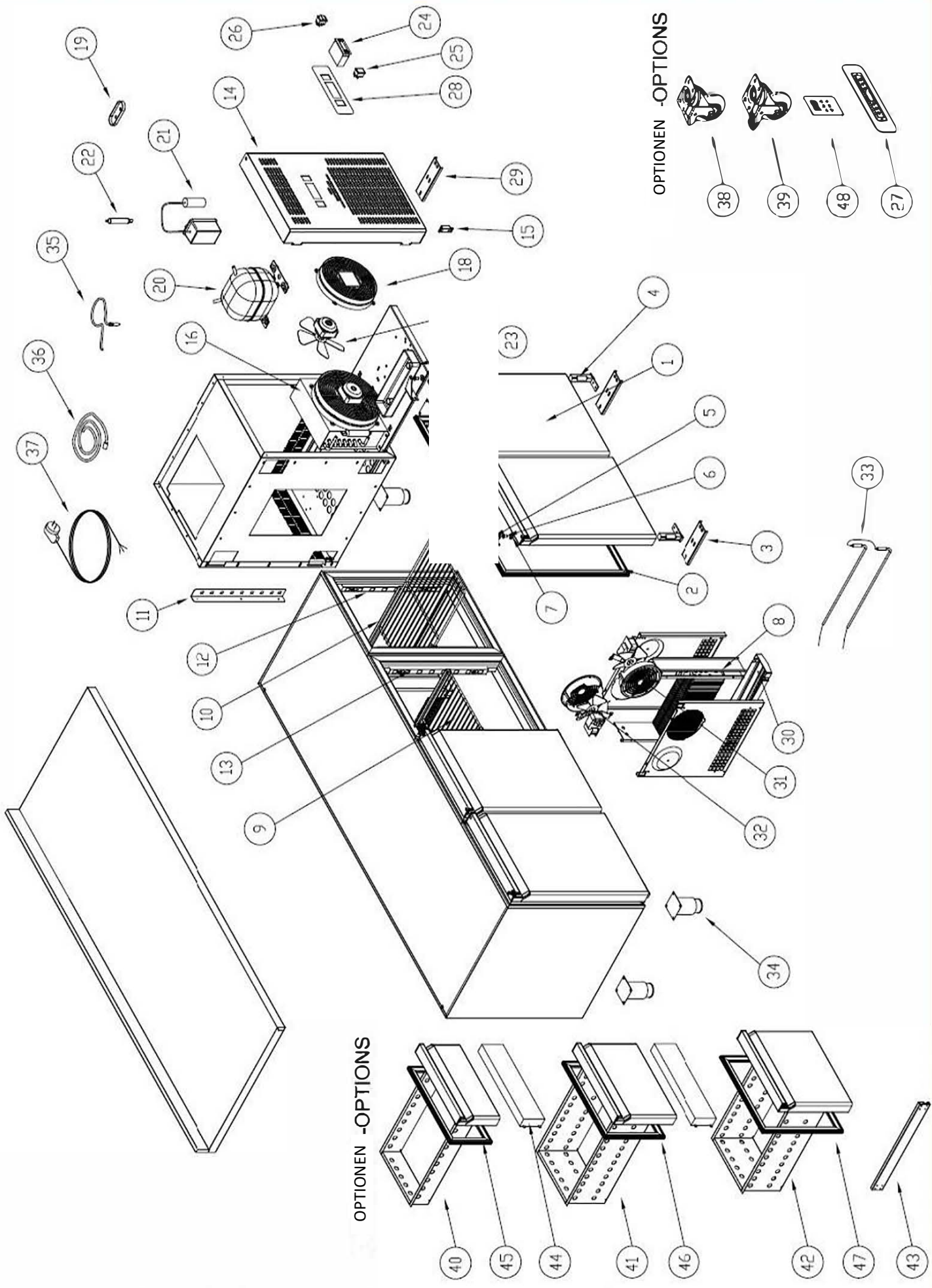

OPTIONEN -OPTIONS

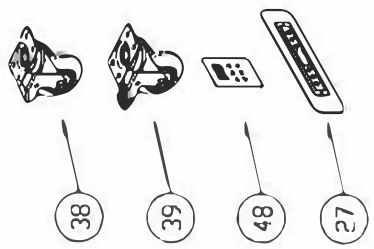

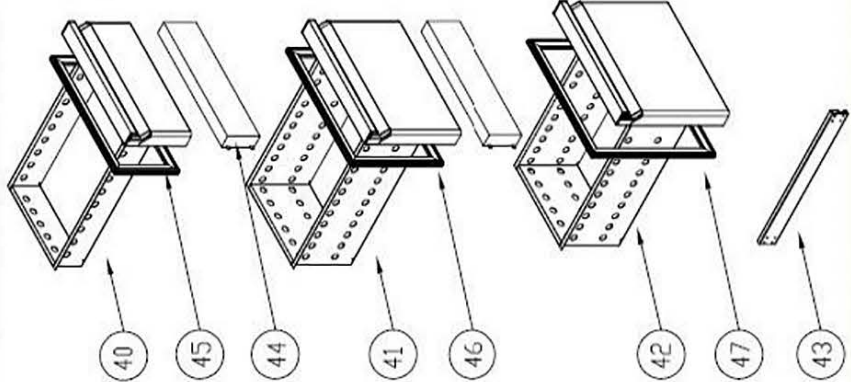

OPTIONEN -OPTIONS

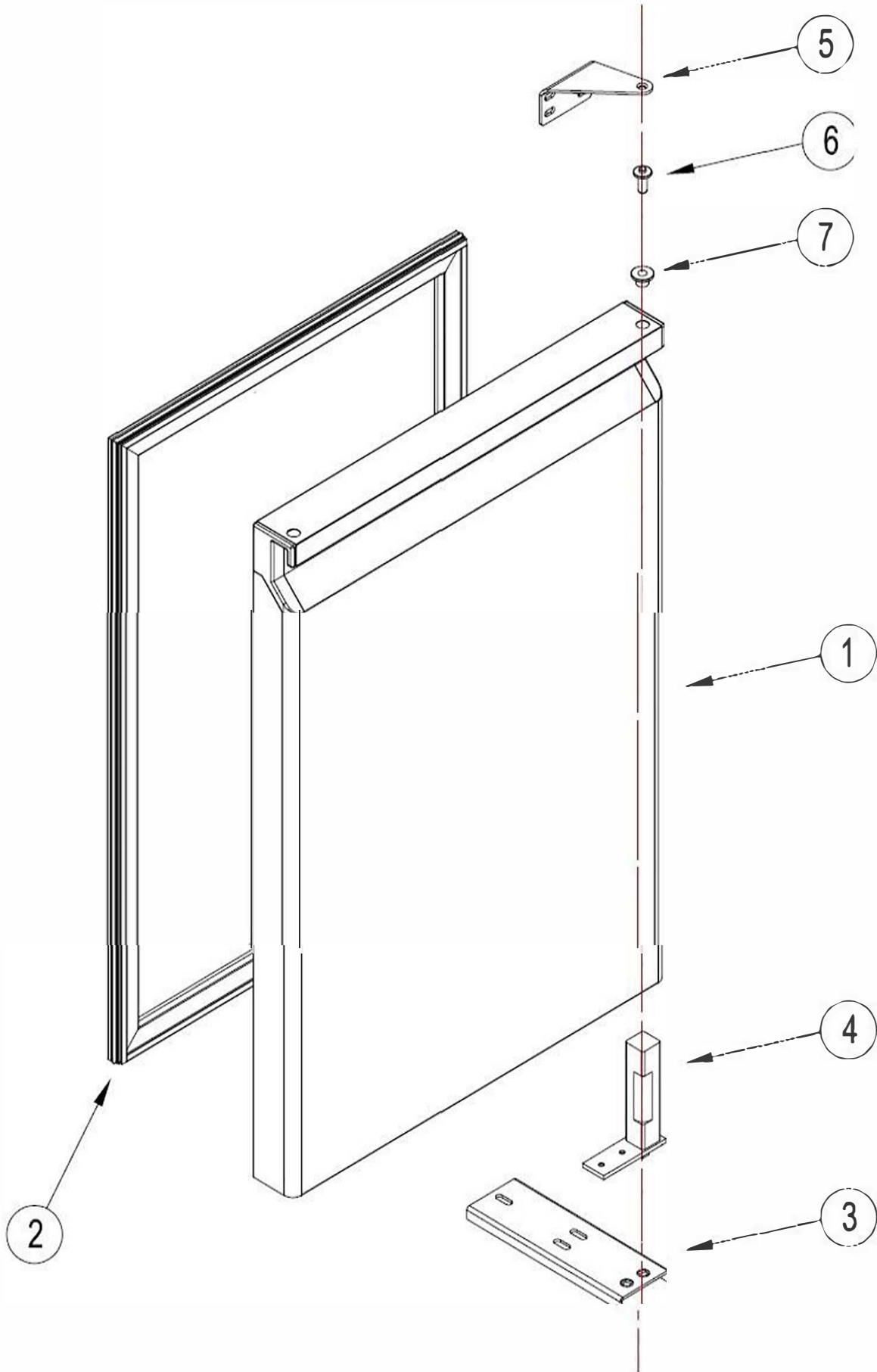



COUNTER TYPE REFRIGERATORS - DOOR DETIAL

	<p>DETAIL EINER HORIZONTALEN SCHRANKTÜR</p>				<p>REV.Nº:</p>	<p>Tarih:</p>
						

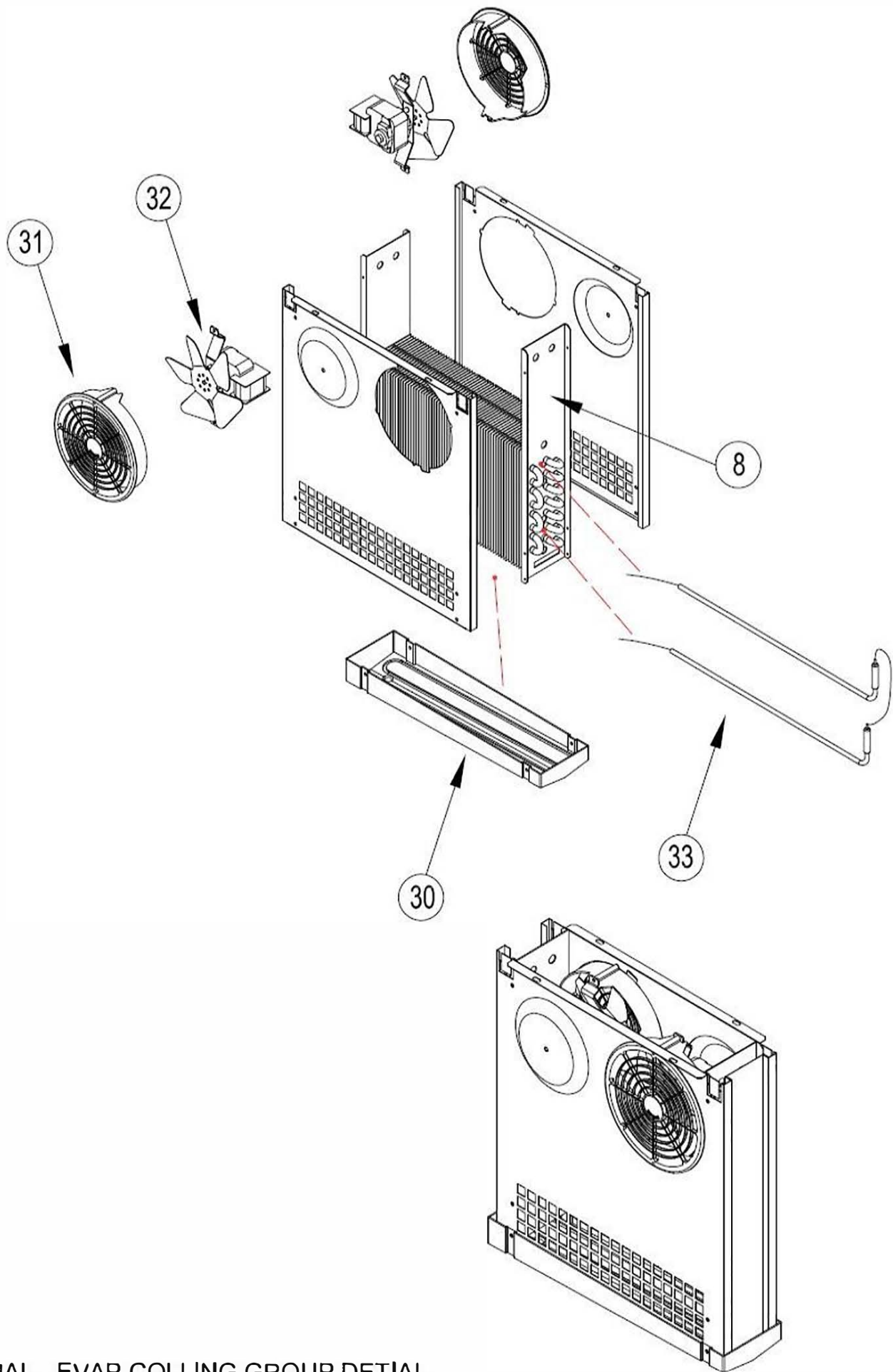

NORMAL - EVAP COLLING GROUP DETIAL

	<p>NORMAL - VERDUNSTUNGSGRUPPE</p>	<p>25.12.2017</p>	<p>REV.N°: 1</p>	<p>Unit: 1000</p>
--	--	-------------------	------------------	-------------------

**KTF226-EF ERSATZTEILLISTE / KTF226-EFPARE PART LIST**

NO	LAGER NR.	TEIL NAME	TEIL NAME	ADET QTY
1	01A01KA121	TÜR	DOOR	4
2	A00CO101	TÜR-DICHTUNG	DOOR GASKET	4
3	30080007	SCHARNIER-TRETLAGER	LOWER HINGE BRACKET	4
4	B02ME100	PFOSTENSCHARNIER UND TEILE	UPRIGHT HINGE AND PARTS	4
5	30080008	OBERER GRIFF	UPPER HINGE	4
6	B01ME104	OBERER HAKENSTIFT	UPPER HINGE PIN	4
7	B01ME103	SCHARNIER KUNSTSTOFFBUCHSE	PLASTIC HINGE BUSHING	4
8	A00EV100	VERDAMPFER	EVAPORATOR	2
9	B01RF101	REGAL - BSN	SHELF-BSN	4
10	P17000126	REGALFÜHRER - BSN	SHELF GUIDE - BSN	8
11	C17000225-A	REGAL STANDARD - RÜCKSEITE	SHELF STANDARD - BACK	6
12	C17000225-B	REGAL STANDARD - SEITE	SHELF STANDARD - SIDE	4
13	C17000225-C	REGAL STANDARD - MITTEL	SHELF STANDARD - MIDDLE	6
14	C16000224	KAJÜTDACH	CANOPY	1
15	B01ME112	MAGNETHÄNGE	MAGNETIC HINGES	2
16	A00KN111	1/2 Hp KONDENSATOR	1/4 Hp CONDENSER	1
17	A00FA128	LÜFTERMOTOR	FAN MOTOR	1
18	A00EP101	VERFLÜSSIGERLÜFTER KUNSTSTOFF	CONDENSER FAN PLASTIC	1
19	B00TK100	FÜHLERDECKEL	PROBE COVER	1
20	A00KO906	KOMPRESSOR--NEU 6210 U (1/2hp)	COMPRESSOR--NEU 6210 U (1/2hp)	1
22	A00DR100	TROCKNER	DRYER	1
23	B01BH102	KOMPRESSOR-WASSERWANNE	COMPRESSOR WATER PAN	1
24	A00DJ156	EVCO DIGITAL	EVCO DIGITAL	1
27	A00DJ107	PLASTIKSCHUTZ	PLASTIC COVER	1
28	A00DJ105	DIGITALES ETIKETT	DIGITAL LABEL	1
29	P30080009	KANUFFENHÄNGE	CANOPY HINGE	1
30	B01BH101	VERDAMPFER-WASSERWANNE	EVAPORATOR WATER PAN	2
31	A00EP100	LÜFTERSCHUTZ KUNSTSTOFF	PLASTIC FAN PROTECTION	4
32	A00FA146	VERDAMPFERLÜFTERMOTOR	EVAP FAN MOTOR	4
33	B00REZ116	200W WIDERSTAND	200W RESISTANCE	2
34	B00AY100	FUSS AUS ROSTFREIEM STAHL	STAINLESS STEEL LEG	6
35	A00DJ102	PROBE ENDE - 1,5mt	PROBE	1
36	A00DJ109	PROBE ENDE - 3mt	PROBE	1
37	B00FK100	NETZKABEL	PLUG CABLE	1
38	B00AY101	RAD - BREMSENLOS	WHEEL WITHOUT BRAKE	4
39	B00AY102	RAD - MIT BREMSE	WHEEL WITH BRAKE	2
40	01A01CK745	1/3 SCHUBLADE	1/3 DRAWERS	
41	01A01CK722	1/2 SCHUBLADE	1/2 DRAWERS	
42	01A01CK724	2/3 SCHUBLADE	2/3 DRAWERS	
43	A00CK101	SCHUBLADENSCHIENE 60lik	DRAWER RAIL	
44	01A01OR100	SCHUBLADEN MITTLERE BRÜCKE	DRAWERS MIDDLE BRIDGE	
45	A00CO100	1/3 DICHTUNG DER SCHUBLADE	1/3 DRAWER GASKET	
46	A00CO103	1/2 DICHTUNG DER SCHUBLADE	1/2 DRAWER GASKET	
47	A00CO106	2/3 DICHTUNG DER SCHUBLADE	2/3 DRAWER GASKET	
48	A00DJ139-C	WASSERDICHT DIGITAL	WATER PROOF DIGITAL	1
49	A00DJ120-C	BERÜHRUNGSSTEUERUNG DIGITAL	TOUCH CONTROL DIGITAL	1
	01A01EV372	HORIZONTALE SCHUBLADE VERDAMPFERAROT	COUNTER REF EVAPARATOR DOUBLE	1



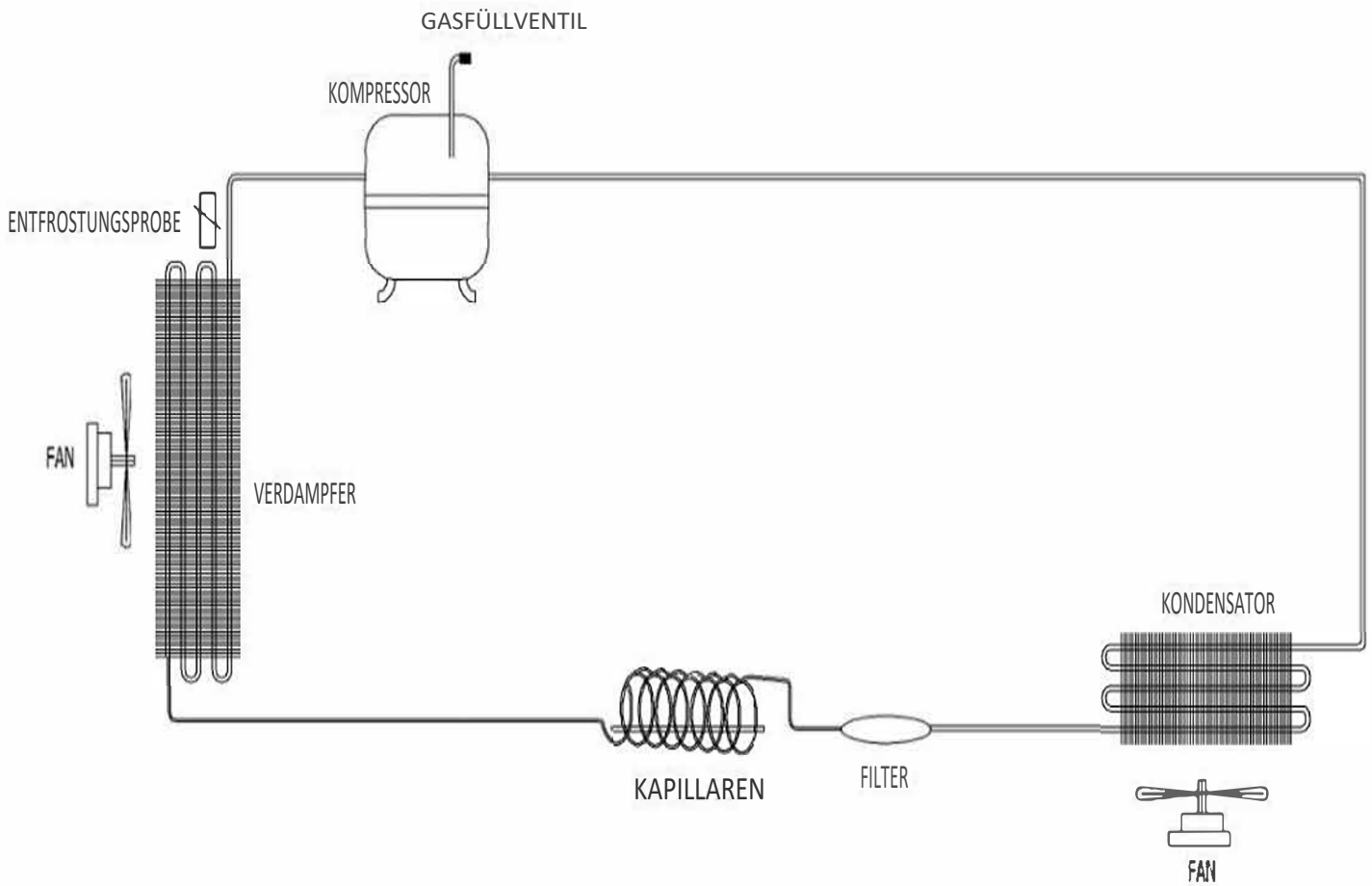

HORIZONTALE KÜHLSCHRÄNKE NORMALES ELEKTRISCHES SCHEMA  
HORIZONTAL REFRIGERATORS NORMAL ELECTRICAL SCHEMA

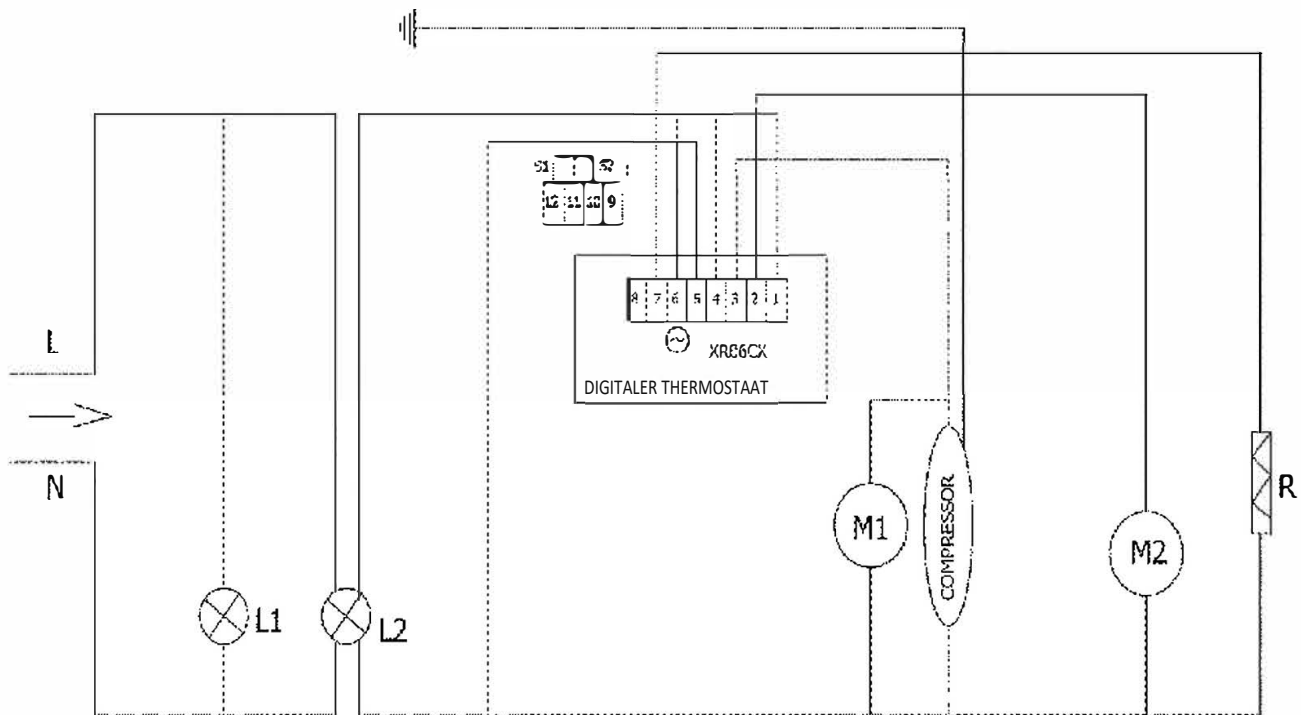

XR060CX : DIGITAL THERMOTER / DIGITALES THERMOSTAT  
M1: VERFLÜSSIGERLÜFTERMOTOR / CONDENSER FAN MOTOR  
M2 : LÜFTERMOTOR / EVAP FAN MOTOR  
S1 : UMWELTSONDE / ROOM PROB  
S2 : VERDAMPFERPROBE / EVAPORATE PROB

L1 : STROMLAMPE / POWER LAMB  
L2 : LAMPE EIN-/AUSSCHALTEN / ON OFF LIGHT  
R: VERDAMPFERWIDERSTAND / EVAPORATE REZISTANCE