

**SFF1546N**  
**TECHNISCHES HANDBUCH**  
**TECHNICAL MANUAL**

**INHALTSVERZEICHNIS / INDEX :**

- 1. MERKMALE / CHARACTERISTICS**
- 2. INNEN- UND AUSSENMA ßE / INSIDE , OUTSIDE DIMENSIONS**
- 3. EXPLOSIONSZEICHUNG / EXPLODED VIEW**
- 4. ERSATZTEILLISTE/ SPARE PART LIST**
- 5. SCHALTPLAN / WIRING DIAGRAM**

# SFF1546N



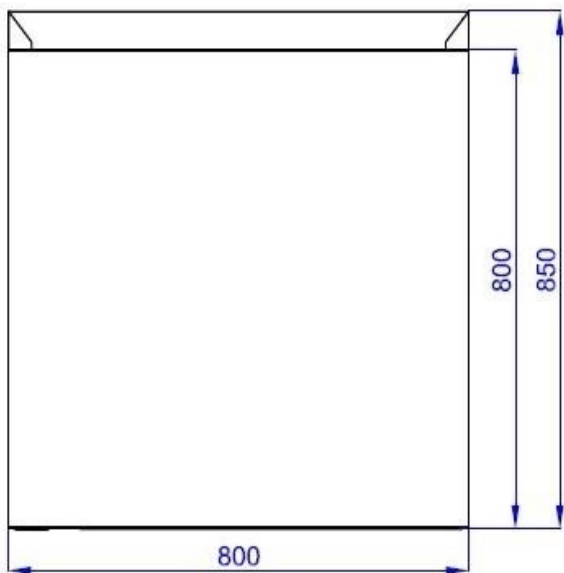
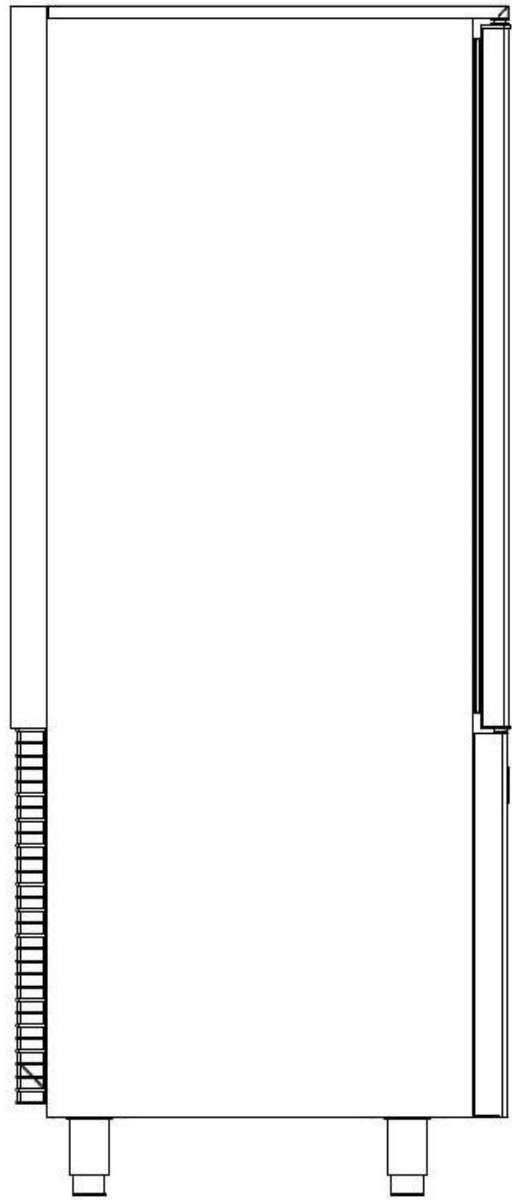
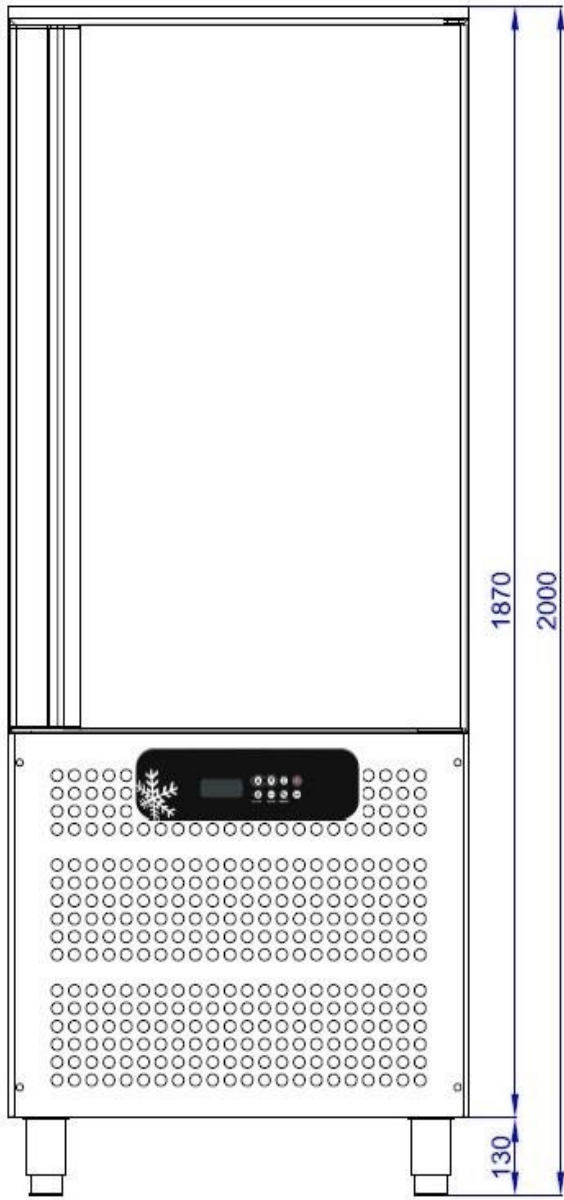

**AUSSENMA E/ OUTSIDE DIMENSIONS = 800x850x2000**  
**INNENMA E/ INSIDE DIMENSIONS = 680x430x1078**

## BESONDERE MERKMALE / CHARACTERISTIC SPECIALITIES

Klimaklasse / Climate class	:N
Sicherheitsklasse / Safety class	:1
Kühltemperatur / Cooling temperature	:+90 / +3C
Gefriertemperatur / Freezing temperature	:+90 / -18C
Thermostat-Solltemperatur / Thermostat set temperature	:-30C
Umgebungstemperatur / Ambient temperature	: +38C
Luftfeuchtigkeit / Humidity	: %65
Energieverbrauch / Energy consumption	: 3 KW/H
Leistung / Power	: 3,50 KW
Spannung - Frequenz / Voltage - Frequency	: 380V / 50 Hz

## ZUBEHÖR UND STEUERSCHALTER/ ACCESORIES AND CONTROL SWITCHES

Digitales Thermometer / Digital thermometer	: Digitales Thermometer /Digital thermometer
Scharniergruppe / Hinge group	: Stk. / Pcs. 1
Standfuß / Stand	: Stk. / Pcs. 4
Regal /Shelf	:15x GN 1/1 + EN 400 x 600 mm :15x GN 1/1 Halterungen / :15 x GN 1/1 brackets

## TECHNISCHE DATEN/ TECHNICAL CHARACTERISTICS

Außenmaße / Outside dimensions	: 800x850x2000mm
Innenmaße / Inside dimensions	: 680x430x1078mm
Verpackungsmaße / Packing dimensions	: 900x950x2160mm
Kühlvolumen / Cooling volume	: 35 kg
Gefriervolumen / Freezing volume	: 30 kg
Bruttogewicht / Gross weight	: 200 kg
Nettogewicht / Net weight	: 180 kg
Außengehäuse / External housing	: 0,60 mm INOX 304 SB+PVC
Innengehäuse / Internal housing	: 0,50 mm INOX 304 MAT+PVC
Dicke des Isoliermaterials/Insulation material thickness	: 60 mm
Volumen des Isoliermaterials / Insulation material volume	: 42 Kg / m3 +/-1
Kompressor / Compressor	: DORIN H300CS--3 HP R404A-R452A
Kondensator / Condanser	: 3,4 KW
Kondensator-Lüfter / Condenser fan	:Hidria R11R - 40LPS-4M-5150 190/260W-0,85/1,1 A 1310/1450 Rpm 50/60 Hz
Verdampfer / Evaporator	: 1,76 KW
Verdampfer-Lüfter / Evaporator fan	: EBM 72/90W , A4E300 , 1320/1500 RPM 0,32-0,4 A Axiallüfter x 3 / Axial fan x 3
Trockner / Dryer	: 3/8
Kältemittel /Refrigerant	: R404A / R452A
Gasmenge/Gas quantity	: 3000 gr
Zertifizierungen / Certifications	: EN 60335-2-89 ve EN 60335-1
Seriennummer / Serial No	: Auf der Verpackung / On the packaging
Verpackung / Package	: Holzpalette , Verpackt in Karton und Nylon / Wooden pallet , Packed in carton and nylon

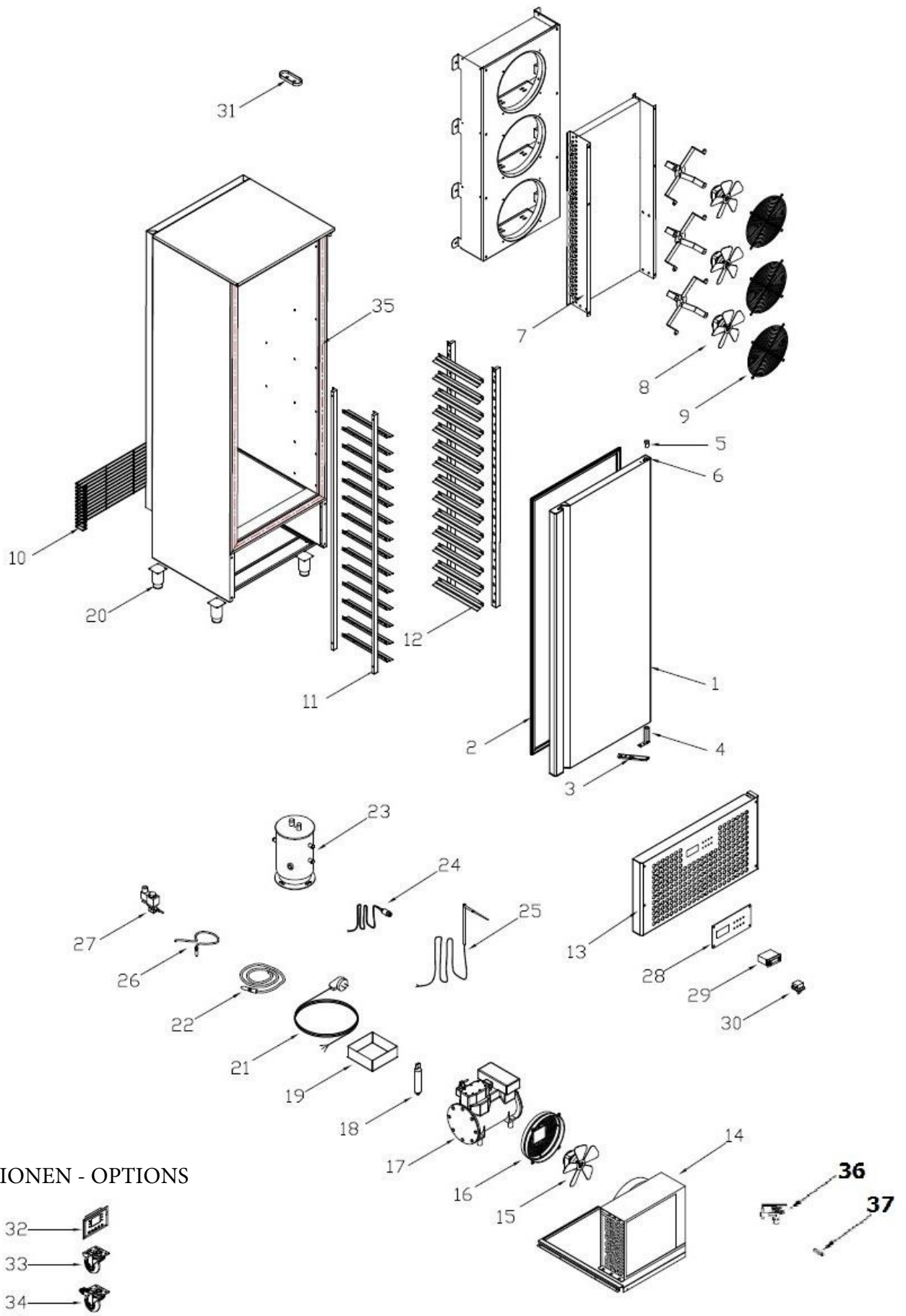

OPTIONEN - OPTIONS

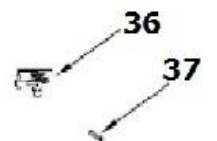
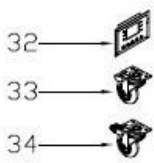

**SFF1546N ERSATZTEILLISTE / SFF1546N SPARE PART LIST**

<b>NR.</b>	<b>CODE</b>	<b>BEZEICHNUNG</b>	<b>DESCRIPTION</b>	<b>ANZAHL QTY</b>
1	01A01KA173	TÜR	DOOR	1
2	A00C0137	TÜR-DICHTUNG	DOOR GASKET	1
3	P30090008	SCHARNIER	HINGE	1
4	B02ME100	SCHARNIER	HINGE	1
5	B02ME101-VBL	SCHARNIER	HINGE	1
6	B02ME102	SCHARNIER MIT BUCHSE	HINGE WITH BUSH	1
7	A00EV110	VERDAMPFER	EVAPORATOR	1
8	A00FA114	VERDAMPFERLÜFTER EBM 72/90	EVAPORATOR FAN EBM 72/90	3
9	A00FA115	LÜFTERABDECKUNG	FAN COVER	3
10	A00FA127	LÜFTERABDECKUNG	FAN COVER	1
11	P11050013	REGALGESTELL	RACK	4
12	P21000101	REGALSCHIENE	RACK RAIL	28
13	P06031007	PLATTE	PLATE	1
14	A00KN109	VBL-15 KONDENSATOR	VBL-15 CONDANSER	1
15	A00FA111	LÜFTERMOTOR	FAN MOTOR	1
16	A00EP111-A	LÜFTERABDECKUNG	FAN COVER	1
17	A00KO118	KOMPRESSOR - H300CS	COMPRESSOR - H300CS	1
18	A00DR100	TROCKNER	DRYER	1
19	B01BH100	WASSERBEHÄLTER	WATER TANK	1
20	B00AY100	EDELSTAHL- FUSS	STAINLESS STEEL LEG	4
21	B00FK100	NETZKABEL	PLUG CABLE	1
22	A00DJ109	SONDE - 3m	PROBE - 3m	1
23	B00LT101	GEFRIERBEHÄLTER	FREEZER TANK	1
24	A00MU101	DRUCKSENSOR	PRESSURE SENSOR	1
25	A00DJ130	SONDE	PROBE	1
26	A00DJ102	SONDE - 1,5m	PROBE - 1,5m	1
27	A00SL101	MAGNETVENTIL 3/8	SOLENOID VALVE 3/8	1
28	A00DJ105	DIGITALES ETIKETT	DIGITAL LABEL	1
29	A00DJ132-EV	EVCO EVX805	EVCO EVX805	1
29	A00DJ132-DI	DIXELL XB07PR	DIXELL XB07PR	1
30	B00DU103	SCHALTER (VERDAMPFER)	SWITCH (EVAPORATOR)	1
31	B00TK100	SONDENABDECKUNG	PROBE COVER	1
32	A00DJ133	TOUCH-BEDIENFELD	TOUCH CONTROL PANEL	1
33	B00AY101	RAD - OHNE BREMSE	WHEEL WITHOUT BRAKE	4
34	B00AY102	RAD - MIT BREMSE	WHEEL WITH BRAKE	4
35	B00REZ135	TÜRRAHMEN	DOOR FRAME	1
36	B00EX101-VBL 15	EXPANSIONSVENTIL-NADEL	EXPANSION VALVE NEEDLE	1
37	B00EX100-VBL 15	EXPANSIONSVENTIL	EXPANSION VALVE	1

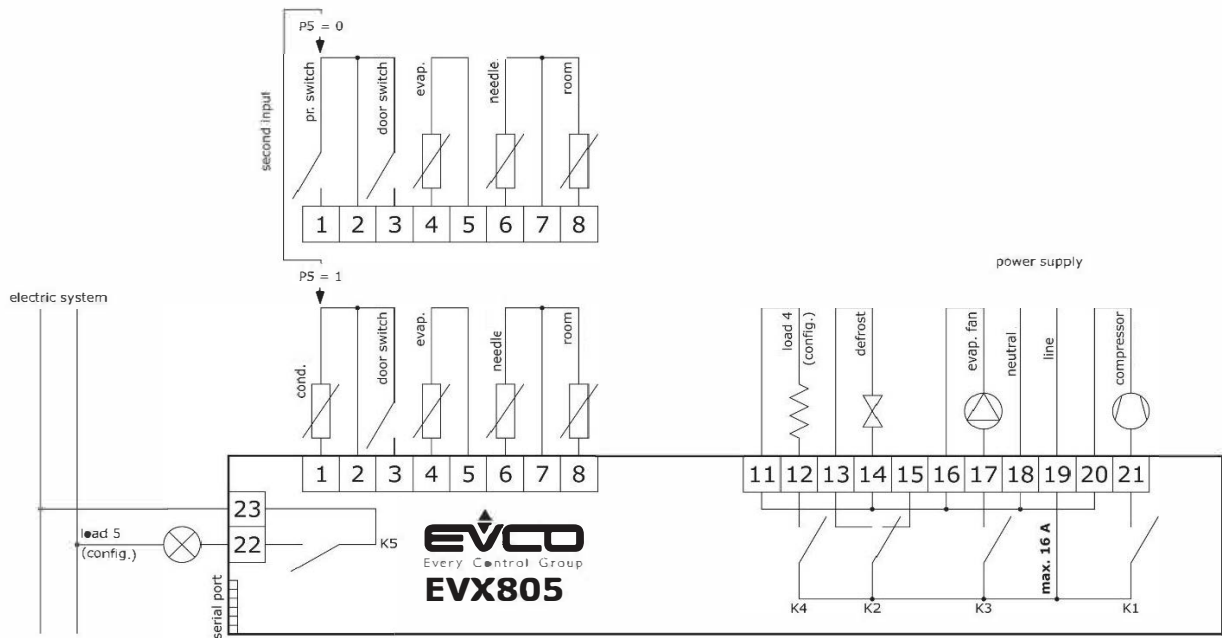

## Dixell

