

# Electric Griddle

## Instruction Manual

EGK55                      EGK75



Thank you for choosing our kitchenware series. Please read the manual book carefully before using the equipment and use only as specified.

This series is our latest generation kitchen equipment .The body is made from Japanese stainless steel and the smooth appearance is based on European styling. They are fully–featured, easily to operate, energy saving and are designed for environmental protection.

### **1. Damage to the appliance**

In the event of any damage to the appliance, it must be turned off immediately and disconnected from the electricity supply by any of removing the fuse, unplugging the unit or manually tripping the circuit breaker.

1.1.1 Ensure power is not supplied to the appliance while repair work is being carried out.

1.1.2 Repairs should only be performed by qualified technicians to ensure safety. Repairs and other work by unqualified persons could be dangerous. Under no circumstances should the outer casing of the appliance be opened.

1.1.3 While the appliance is under warranty, repairs should only be performed by an authorized service technician. Otherwise, the warranty is void.

1.1.4 Old appliances contain materials that can be recycled. Please contact your local recycling center about the possibility of recycling these materials.

1.1.5 Before discarding an old appliance, remove the power cord and any doors to prevent hazards.

## 1.2 Usage

### 1.2 .1 Turning on and off

Turn the power control knob clockwise to turn the hot plate on, or counterclockwise to turn it off.

The operating indicator lamp to the left of the control knob illuminates when the appliance is switched on.

### 1.2.2 After use

Turn off the hot griddle plate. Clean the hot plate with a dry cloth after the hot plate cools down.

## **2. Cleaning**

Clean stainless steel surfaces with a wet cloth and then wipe dry with a soft cloth. Soak baked or hardened spills first to loosen them.

Stainless steel surfaces can be cleaned using a non-abrasive stainless steel cleaner.

To help prevent soiling, a conditioner for stainless steel can also be used. Apply sparingly with even pressure.

## **3. Frequently asked questions:**

3.1 All repairs should be performed by a trained technician in strict accordance with national and local codes. Any repairs or maintenance performed by unqualified personnel could be dangerous.

3.2 What if the hot plate does not heat up when turned on?

Check whether:

- The overheating protection has been activated.
- The electrical circuit has blown a fuse or "tripped" the circuit breaker.

3.3 If power cannot be restored, it may be necessary to call either an electrician or

the Technical Service Department.

### 3.4. Trouble shooting

Problem	Reason	Solution
1. The green indicator light is not lit when you turn the power on.	1.The power fuse is burned out 2.The power wire is Improperly connected. 3.The light has burned out	1.Replace with a suitable fuse 2.Tighten the power wire connection 3.Replace the light
2. The yellow indicator light is always lit. You cannot control the temperature.	1. The indicator light is improperly connected.. 2.the thermostat has failed	1. Connect the light correctly. 2.Replace the thermostat
3. The yellow indicator light is not on; the temperature can be controlled normally.	1. The indicator light is improperly connected. 2. The indicator light has burned out.	1.Connect the light correctly 2、 Replace the light

## 4. Parameter character

- A. With automatic temperature controller to keep the temperature from 50°C~300°C.
- B. Insulation materials. The double layers of insulation are safe, energy saving and highly effective.
- C. Both the rise and fall hot plate could heat at the same time, so the food heating is more completely.

## 5. Basic parameters

## 5.1 Specifications

NAME	Electric Grill	Electric Grill
MODEL	EGK75	EGK55
VOLTAGE	220V 50HZ	220V 50HZ
POWER	4.4KW	3KW
NUMBER OF CONTROLLOR	1	1
TEMPERATURE RANGE	50°C~300°C	50°C~300°C
DIMENTION (mm)	730*500*230	550*450*230

## 5.2 Component Diagram

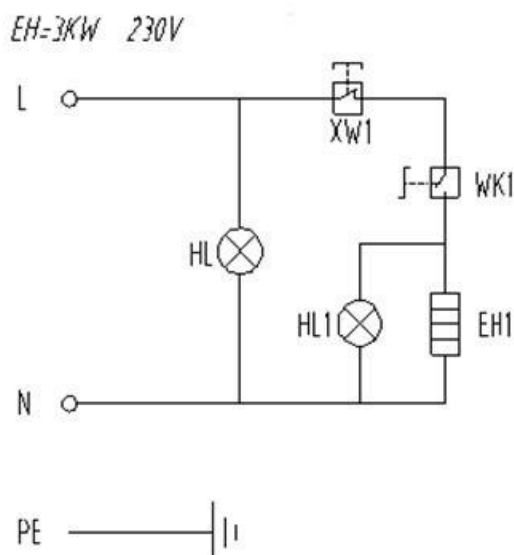

WK1- temperature controller

XW1-temperature limiter

HL-power signal lamp

HL1-heating signal lamp

EH1-electric heating pipe

PE-connected to the ground

## 6. Operating Instructions

### 6.1 Safety Instructions

If there is any abnormal appearance while you are using the equipment, turn off the power immediately. Do not use until safety is assured.

## 6.2 Griddle

A. Turn on the power source and the green power indicator light should come on. Select the desired power level and proceed to cook.

B. According to your need to choose the suitable temperature. The temperature range can be adjusted from 50~300°C.

## 6.3 Installation

a. Put the stove on level ground and ensure a clearance of at least 10cm from both right and left side, and at least 20cm from behind.

b. The working voltage must match the one on the specification plate.

c. Install the allowable power source; fuse plug and grounding protection to the equipment. Do not put anything in front of the power switch.

d. The power connection is under the stove in the rear corner and connects to ground for safety.

e. The ground wire (yellow and green wire) and power source wire are in the same wiring harness. Connect the ground wire by suitable copper bolt if the power point doesn't have one.

## **Attention**

A. In order to prevent destruction from thunder, turn off power as soon as possible while the thunder is closing in.

B. Do not destroy the surface or heat plate with solid or sharp objects.

C. Turn off the power source after cooking is finished.