

Contact Grill

User manual



Thanks for your purchasing and using Contact Grill. For making full use of function of this product and reducing unnecessary damage and injure. Please read this manual carefully before using this machine and keep it well for future reference.

Warning! Any refitting and wrong installation, adjustment and maintenance can lead to property loss and causality. Please contact the supplier if user needs to adjust it and all these should be done by trained special professionals.

Warning! For your safety sake, do not put or store any flammable liquid, gas or other objects around the product.

Warning! The shell of this equipment must be grounded for safety sake. Thanks for your cooperation!

Contact Grill is designed and developed by the company with combination of the advantage of both foreign and domestic similar products and achieves advantages such as fashionable design, reasonable structure and convenient operation and maintenance and durability. The temperature of the griddle pan can be regulated in a certain scale according to different cooking requirements. Mainly used for grilling the beef of sandwich and also for other food, it is the first choice for the food industry enterprises such as western food restaurants, fast food restaurants, hotels and supermarkets and etc.

Exterior Structure

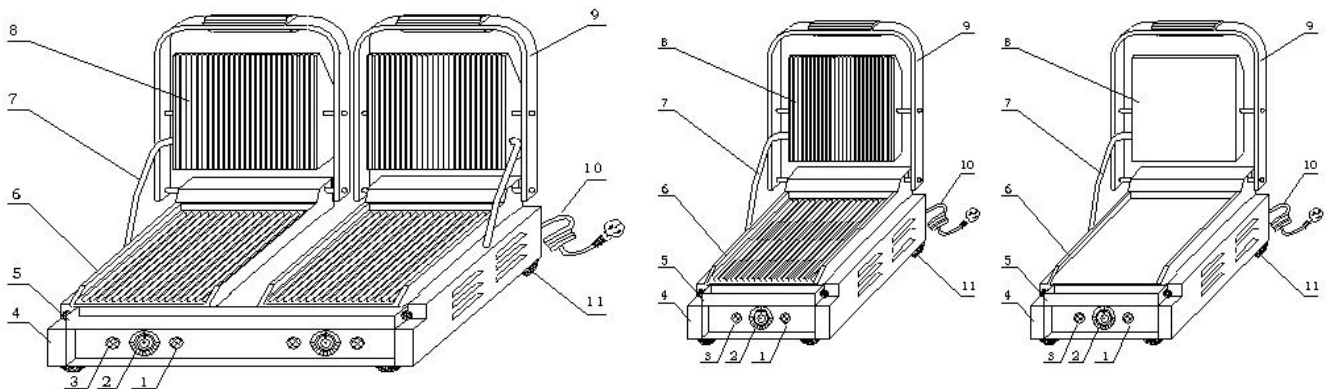

- 1—HEATING INDICATOR 2—TEMEPRATURE CONTROLLER
3—POWER INDICAOTR 4—BOTTOM BOX
5—OIL TRAY 6—LOWER MODULE PLATE 7—FEED WIRE TUBE 8—UPPER
MODULE PLATE 9—OPERATION HANDEL 10—POWER CORD
11—RUBBER FEET

Features of Function and Structure

1. The upper and lower module plates are enameled and are easy to be cleaned.
2. One-headed and double-headed grilling pans can be chosen freely.
3. Independent temperature controlling system are convenient to handle and can achieve energy economy as well.
4. Internal temperature protector is reliable and safe.
5. Grilling temperature can be adjusted according to different requirements.
6. It is made by stainless steel and the drawer-style oil tray is also made of stainless steel.
7. It is easy to lift up and down and convenient to handle and maintain.

Specification

Name	Contact Grill single Upper/lower ribbed	Contact Grill double Upper/lower ribbed	Contact Grill single Upper/lower ribbed
Model	KGJ432	KGJ542	KGJ442
Voltage	220~240V 50/60Hz	220~240V 50/60Hz	220~240V 50/60Hz
Power	1.8KW	3.6KW	2.2KW
Temperature controller number	1	2	1
Temperature range	50~300°C	50~300°C	50~300°C
Upper grill size	214×214(mm)	214×214(mm)	338×235(mm)
Lower grill size	235×225(mm)	485×235(mm)	345×235(mm)
Weight	14kg	27kg	20kg

Transportation and Storage

Please handle the griller carefully and cautiously in transportation and do not turn it upside down to prevent any damage to the shell and interior. The packed griller should be stored in the storehouse ventilation and non-corrosive gas. Any weatherproof measures should be applied when temporary storage.

Notes

1. The working voltage of the equipment should match that of the power supply.
2. Suitable switch, fuse breaker and three-phase socket should be installed near the equipment.
3. There is an earth bolt at the back of the equipment. Please connect the earth wire in compliance with the safety regulations reliably with copper cable of no less than 2mm.
4. Before using user should check whether connection is firm and voltage is regular and earth connection is safe.
5. Do not put any object onto the upper module plate and shake the lift operation handle with sudden force.
6. Cut off power supply while cleaning. Do not use wet towel with corrosive cleanser and do not directly splash water on the equipment.
7. The adjustable temperature of the equipment is between 50~200°C. It is recommended that the maximum working temperature normally should be 200~250°C.
8. Do not store any flammable objects near the equipment. The

environment temperature lower than 45°C, the humidity is under 85%.

9. The installation and maintenance of the equipment should be made by professional technicians.

Special Notes

WARNING!	
●	This product is a commercial machine and it must be operated by trained cook.
●	Do not dismantle and refit the machine. Do not lift the upper module plate with sudden force and tilted installation. The dismantlement and alteration can cause serious accident happens.
●	Before cleaning, unplug the machine and cut off power supply. Do not spray water directly to the product. Water can conduct electricity and electricity leakage happens.
●	Do not pat the product and put heavy object onto the product. Incorrect operation can cause the equipment be damaged and dangerous.
●	High temperature will cause scald. When the equipment is in use and before or after using it, do not touch the box and module plate because of high temperature.
●	Do not use any power supply which is not coordinated with safety standards.

NOTICE!	
●	When the thunderstorm is coming, the electricity supply must be cut off soon. It will avoid the equipment being damaged in cause of lightning stroke.
●	Do not destroy the control panel and the surface of the machine with hard or sharp things.
●	When the machine finishes using , user should close main switch.
●	The installation and maintenance of circuit must be done by certificated special professionals. If the supply cord is damaged, it must be replaced by the manufacturer or its service agent or a similarly qualified person in order to avoid a calamity.

Operation Instruction

1. Before using, check whether the power supply installation is regular to make sure the supplied voltage is coordinated with the using one.
2. Put the plug in the socket and turn on the power.
3. Turn the temperature controller clockwise to the temperature needed. The yellow indicator is on that shows heating wire begins to heat and the upper and lower griddle begins to raise temperature.
4. Temperature can be adjusted according to different food preferably within 180°C~250°C. About 8 minutes is needed for the temperature to be raised to 250°C from the power is on.
5. When the temperature reaches 250°C, lift the upper module plate to a suitable place by operation handle. Put some edible vegetable oil on the lower module plate and constantly place the food on it. Close the plates and press the handle lightly. Keep an eye on the food until it is suitably done.
6. When temperature reaches the setting degree, temperature controller can cut off power supply automatically. At the same time, yellow indicator is off and green indicator is on. It shows that electricity heating tube stops working for next turn.
7. At the lower front of the lower module is the oil tray. Substantial vegetable oil and the animal oil from the meat grilled flow to the oil tray from the lower module plate.
8. Lift the upper module plate to take the sandwich and other food already done.
9. When the temperature is a bit lower, the temperature controller can get through power supply automatically. The heating tubes restart to work to heat the module plates.
10. On completion of the work, temperature controller should be turned to the “off” place. Unplug the equipment and cut off the power.

Notice: There is temperature limiter in the bottom box, the action temperature is 130°C, and reset temperature is < 40°C. When temperature is over the protective button works for protection. When use it again, please use it after press the protective button.

Cleaning and Maintenance

1. Cut off the power supply before cleaning in case of accident.
2. Do not use wet towel with non-corrosive cleanser to clean the module

plate, the surface of the equipment and power cord. Direct wash by water is not permitted in case of any damage of the functions.

3. If do not use it at any time, please turn off temperature controller and main switch.

4. Please store the equipment in a ventilated storehouse without corrosive gas after cleaning when ceasing its work for a long time.

Breakdowns analysis and fixing

Fault phenomenon	Causes	Elimination methods
1. Module plates are out of heating when the power and heating indicator are both on.	1. Temperature controller is broken. 2. At least one of heating wires is burned. 3. Temperature protector works.	1. Change temperature controller. 2. Change the burned heating tube. 3. Dismantle the bottom plate and use hand to reset temperature protector.
2. When the power is on and temperature controller is switched and heating indicator is on and temperature can be not controlled.	1. Temperature controller is out of order.	1. Change temperature controller.
3. Indicator is not on when the power is on and the heating process is normal.	1. Indicator is broken.	1. Change temperature controller.
The indicator is out of order when the power is on.	1. Abnormal power supply or cut-off power supply. 2. Fuse is burned.	1. Check power supply and connection to make power supply be normal. 2. Change fuse.

Aforementioned troubles are just for reference. If any fault occurs, please cease using and turn to professional technicians for check and repair.

Circuit Diagram

THE SHELL OF THIS MACHINE MUST BE EARTH GROUNDED FOR SAFETY SAKE. THANKS FOR YOUR COOPERATION.

KGJ432/KGJ442

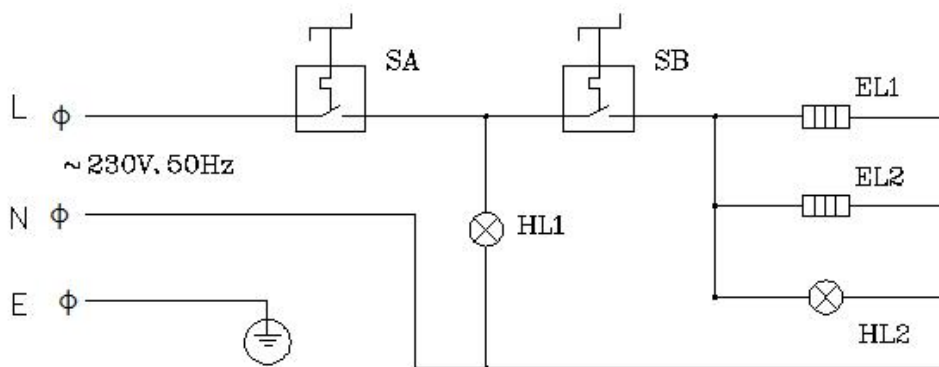

Remarks: SA- Temperature limiter HL2- Heating light
SB- Thermostat EL1- Up element
HL1- Light EL2- Down element

KGJ542

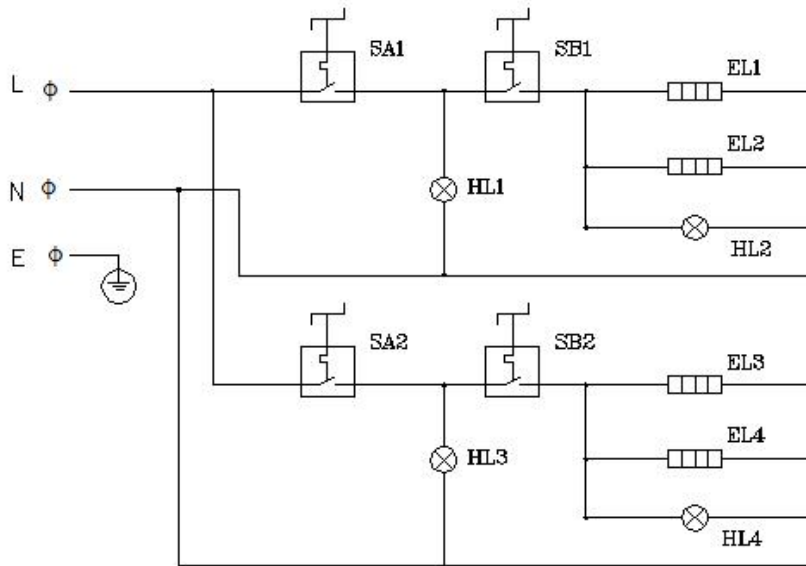

Remarks: SA1;SA2- Temperature limiter HL2;HL4- Heating light
 SB1;SB2- Thermostat EH1;EH3- Up element
 HL1;HL3- Light EH2;EH4- Down element

Daily Check

Everyday notice the situation of the machine before or after using.

Before using	Whether the machine is tilted?
	Whether the power cord is old, broken or damaged?
	Whether the control panel is damaged?
After using	Whether there is strange smell?
	Whether the upper and lower module plate cannot be heated at the same time?
	Is there any strange voice or is the machine out of control while the machine is lifting?

WARNING!

- Must check the machine everyday.
Usually check the product that can avoid serious accident happens.
- Stop using if user feels that there are some problems in the circuit or machine.
Ask the special technicians to check and maintain the machine as soon as possible.

**GGM Gastro International GmbH,
Weinerpark 16, 48607 Ochtrup
www.ggmgaastro.com**