

LECTRIC PASTA COOKER

ENH8/ENH8+8

INSTRUCTION MANUAL



ENH8



ENH8+8

First of all, we would like to express our sincere gratitude for your choice of our desktop electric spaghetti cooker. All the information and guidelines in this instruction manual are compiled in compliance with applicable regulations, based on the current state of engineering development as well as our long - term knowledge and experience.

In case of special structures, additional specified options, or due to changes in new technologies, the actual scope of supply may deviate from the descriptions and instructions provided herein. If you have any questions, please contact the manufacturer.

To fully unleash the performance of this product and reduce unnecessary losses and damages, please carefully read the instruction manual before starting any operation on the device, especially before starting the device!

The manufacturer shall not assume any liability for damages or negligence caused by illegal operation.

This instruction manual should be stored directly on the device for easy access by the device operator. Within the scope of improving performance characteristics and further development, our company reserves the right to make technical changes to the product.



Warning

- ◆ Any modification, incorrect installation, adjustment, repair or maintenance may lead to property damage or personal injury. If adjustment or repair is required, please contact the supplier, and it should be carried out by trained professionals.
- ◆ For your safety, please do not store or use flammable, explosive gases, liquids or articles near this product.
- ◆ This product should not be used by people (including children) with physiological, perceptive or psychological dysfunctions or those who lack experience or knowledge, unless there is someone to supervise their safety or give instructions on how to operate the product.
- ◆ Please supervise children to ensure their personal safety.
- ◆ Please keep the instruction manual carefully. If the product is handed over to a third party for use, please deliver the instruction manual along with it as well. All users of the device must adhere to the information in the instruction manual and the safety guidelines.
- ◆ If the appliance is positioned close to walls, partitions, kitchen equipment, decorative panels and other locations, it is recommended that these equipment and facilities be made of non-combustible materials. Otherwise, they should be covered with appropriate non-combustible thermal insulation materials, and close attention should be paid to fire prevention regulations.

- ◆ There are no user-replaceable spare parts for this product. To avoid product damage and personal injury, please use original parts during maintenance.
- ◆ The outer casing of this machine must be grounded to ensure safety. Thank you for your cooperation!

CONTENT

1. Brief Introduction to Product FunctionsFehler! Textmarke nicht definiert.

2. Structural Schematic Diagram and Working PrincipleFehler! Textmarke nicht definiert

2.1 Structural Schematic Diagram 5

2.2 Structural Performance Characteristics 7

2.3 Electrical Schematic Diagram 8

3. Product Specification Parameters..... Fehler! Textmarke nicht definiert.

4. Precautions..... Fehler! Textmarke nicht definiert.

4.1 Transportation and Storage 10

4.2 Installation and Precautions 10

4.3 Special Precautions **Fehler! Textmarke nicht definiert.**

5. Instruction Manual	Fehler! Textmarke nicht definiert.
6. Daily Inspection	Fehler! Textmarke nicht definiert.
7. Cleaning and Maintenance	Fehler! Textmarke nicht definiert.
8. Fault Analysis and Troubleshooting	19

1. Brief Introduction to Product Functions

The ENH series of desktop electric pasta cookers are developed and designed by our company. Meanwhile, their design also absorbs the advantages of similar products at home and abroad. They feature novel styles, reasonable structures, convenient operation, sturdiness and durability, as well as easy maintenance. Made entirely of stainless steel, they are both aesthetically pleasing and durable. Equipped with high-quality heating tubes, fully automatic thermostats and temperature limiters, they are safe and reliable.

2. Structural Schematic Diagram and Working Principle

2.1 Structural Schematic Diagram

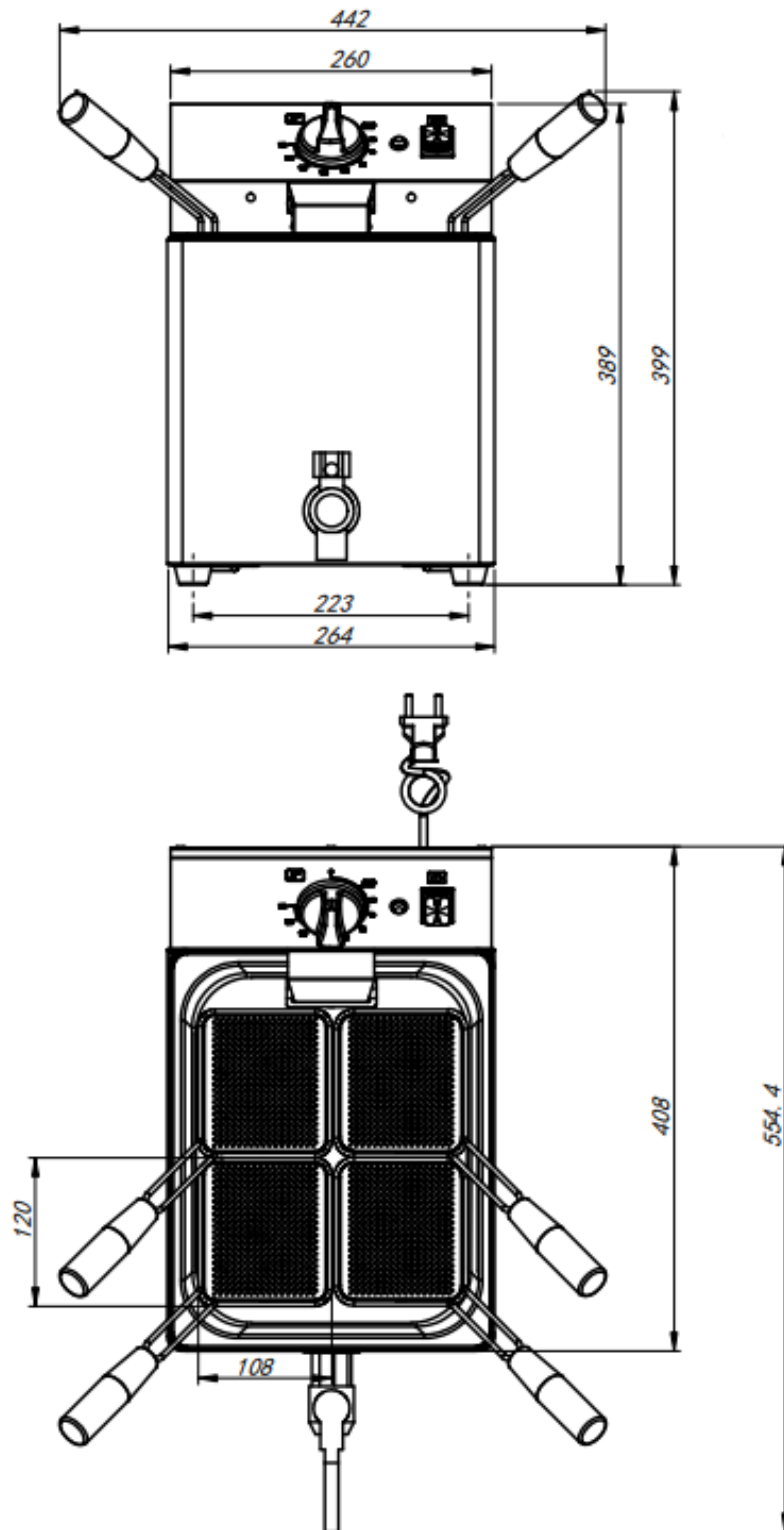

ENH8 Pasta cooker three-view drawings

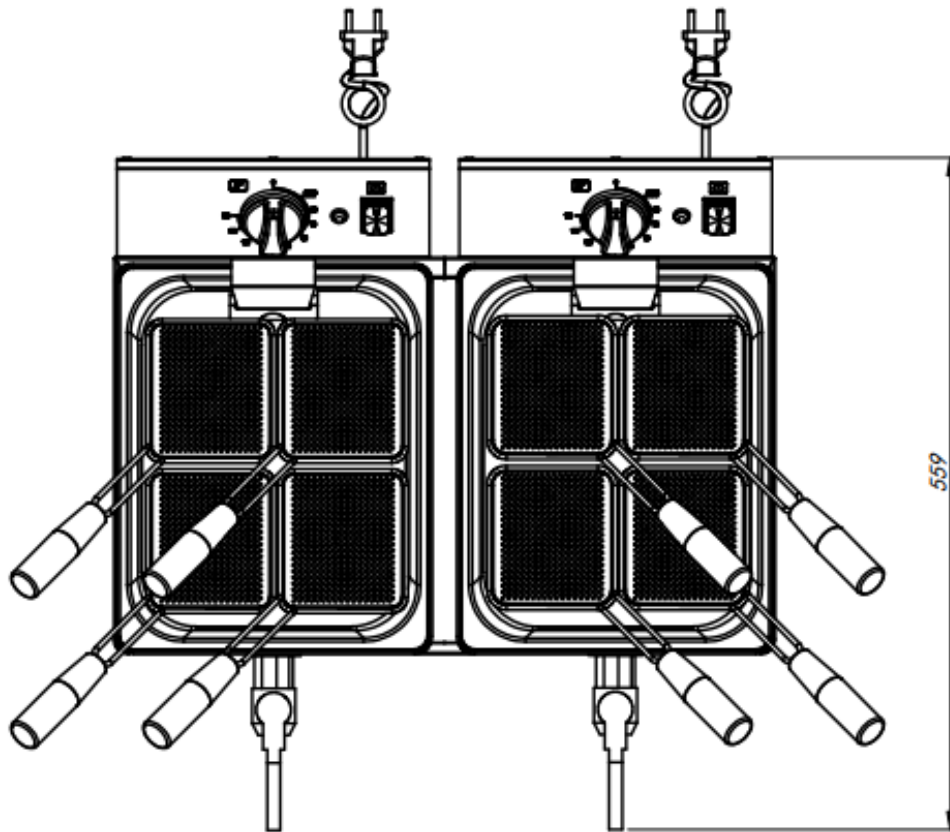
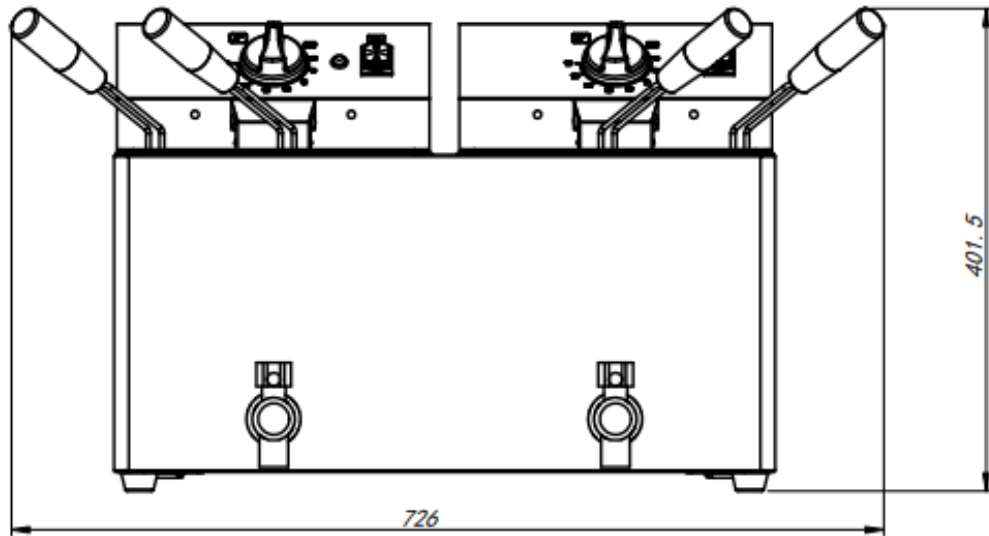

ENH8+8 Pasta cooker three-view drawings

2.2 Structural Performance Characteristics

1. Made entirely of stainless steel, it is both aesthetically pleasing and durable. With a stretched cylinder body, there are no blind spots for hygiene.
2. Equipped with high-quality heating tubes, a temperature control switch and a fully automatic temperature limiter, it will automatically cut off the power when the water temperature reaches as high as 125 °C. It is easy to operate, safe and reliable.
3. The large cylinder body and pasta sieve (noodle cooker) can improve the utilization rate.
4. Each pasta cylinder is equipped with high-quality heating tubes.
5. The temperature control switch is placed at the front, and there are enlarged control knobs for convenient operation.

2.3 Electrical Schematic Diagram

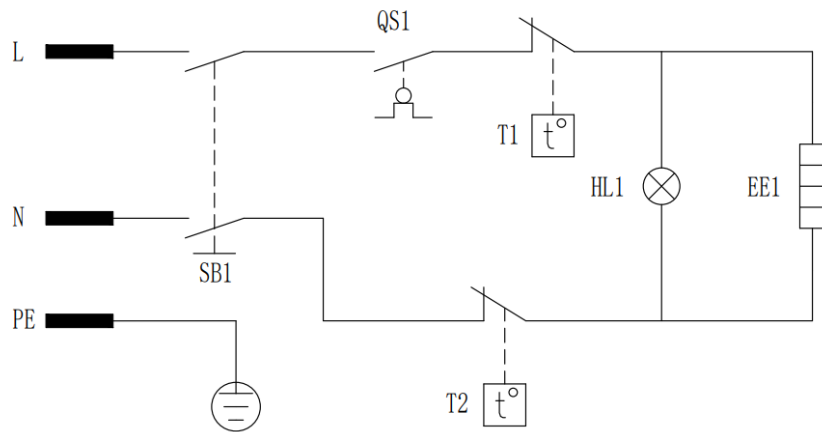

ENH8/ENH8+8 / 230V

No.	Code	Name	Model/Specification	QTY
1	SB1	On/off switch	R595KDFT1FA-JKA/On/off button 125V 20A red	1
2	T1	Temperature adjuster	WY110-653-21/110°C/250V/16 A	1
3	HL2	Indicator light	230V/yellow, no wire	1
4	QS1	Micro switch	HDF/MS1-16	1
5	T2	Temperature limiter	WQS-125-001/125°C/250V/16 A(Without plugs and nylon rings)	1
6	EE1	Heating element	Deep fryer 8L/HDF8/230V/3250W	1

3. Product Specification Parameters

Model No.	ENH8	ENH8+8
Electrical parameters	230V/50Hz/3250W	230V/50Hz/3250W*2
N.W.	7.42kg	13.65kg
G.W.	9.97kg	16.7kg
Product Net Dimensions	470*475*410(mm)	758*475*410(mm)
Packing Size	340*530*455(mm)	630*530*455(mm)
Basket Size	120*108*146(mm)	120*108*146(mm)

4. Precautions

4.1 Transportation and Storage

During transportation, this cooker should be handled with care and must not be placed upside down to prevent damage to the product's outer casing and internal components. The packaged cookers should not be stored outdoors for a long time. Instead, they should be placed in a warehouse with good ventilation and free of corrosive gases. When temporary storage is required, rainproof measures should be taken.

4.2 Installation and Precautions

Electrical connection:

1. The connection of the power cord of the equipment must be carried out by professionals. The power cord used should have sufficient current-carrying capacity. The installation of the power cord must be firm, and the fixing screws must be tightened. For the safety of the equipment during use and the safety of personal lives, the neutral wire and the ground wire cannot be shared. The ground wire should be reliably grounded. It should be easy to disconnect independently. The ground wire should be reliably grounded and cannot be controlled by switches, as shown in the diagram.

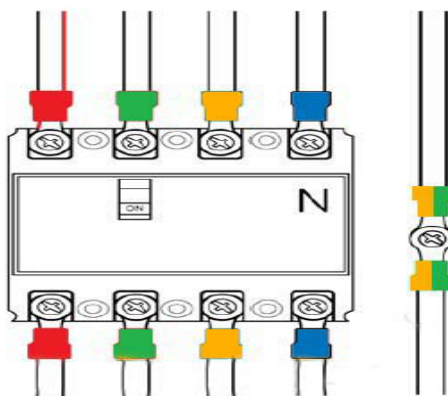

Attention: The manufacturer will not be held responsible for any problems caused by failure to comply with safety regulations.

2. When connecting to the power supply line, the power supply of the equipment needs to be connected to the power grid after passing through an external leakage protection switch with sufficient current-carrying capacity.

The leakage action value is 30 mA, and the action time is less than 0.1 seconds. (This product is not equipped with this device.)

3. Use the flexible copper-core power cord of oil-resistant sheathed cables with the models of "YCW" or "YZW" (this product is not equipped with this power cord). The external power cord of the equipment must be protected by metal or hard plastic pipes.

4.  Meaning of equipotential: The equipotential connection in electrical appliances refers to connecting the exposed metal and conductive parts of various electrical devices and other devices in electrical appliances to artificial or natural grounding bodies with conductors, so as to reduce the potential difference (reduce and prevent the risk of electric shock).

5. After installation, it should be checked whether all the connections are loose, whether the voltage is normal and whether the safety ground connection is reliable.

Precautions:

1. The installation of this equipment should be carried out by professional technicians.
2. The connection of the equipment must comply with the regulations on electrical safety, installation and use.
3. The equipment should be installed separately within the specified range or

installed in combination with other equipment as required.

4. There should be a clearance of more than 10 cm from non-combustible materials on the left and right sides of the equipment during installation, and a clearance of more than 20 cm from non-combustible materials (such as brick walls, windows, etc.) at the back. It must not be installed on flammable floors or materials.

5. Since the equipment is rather heavy, please take its weight into consideration during installation. We recommend that you install it on the ground.

6. The installation location should be in a well-ventilated area, and exhaust facilities should be installed to ensure that the oil fumes can be discharged during operation.

7. The installed equipment must be kept stable, placed horizontally without tilting, and should not shake during use.

8. Remove the plastic film on the outside of the product before installation, and use a suitable tool to remove the residues on the stainless steel plate.

9. Before installation, it is necessary to apply for and obtain the permission of the electrical supplier to use this voltage, and verify that the supplied voltage is consistent with the voltage to be used in the future before installation can proceed.

10. The power supply voltage must match the operating voltage of the equipment.
11. Never place flammable items (such as towels, etc.) on any position of the stove surface, otherwise it may cause combustion and lead to fire accidents.
12. Immediately turn off the power switch after use.
13. Flammable and explosive items must not be stored near the installation location. The ambient temperature should be lower than 45 °C, and the relative humidity should be below 85%.

4.3 Special precautions:

1. The installation, initial use and maintenance of this equipment should be carried out by professional personnel, those who have obtained the installation operation certificate, or those approved and licensed by the manufacturer.
2. Remove the outer packaging and ensure the integrity of the equipment. If you have any questions, please do not use the machine and consult professional personnel. Do not place the packaging materials where children can reach them to avoid danger. (The materials are plastic bags, nails, etc.)
3. When the equipment is not in use or when the operator is absent, the equipment must be turned off to avoid danger.

4. This product is a commercial machine and is not suitable for household use.

Its operation should be carried out by trained personnel.

5. This machine is for commercial use only and is not applicable for other purposes, otherwise it may cause danger.

6. Do not shake or tilt the machine during use.

7. Do not disassemble or modify it. Disassembling and modifying the product may lead to serious accidents.

8. Before cleaning, unplug the plug and cut off the power supply.

9. When cleaning, please do not directly rinse the equipment with water.

Water can conduct electricity, and the product may cause an electric shock accident due to leakage.

10. Do not pat the product or place heavy objects on it.

11. Abnormal operation may cause damage to the equipment and danger.

12. High temperature may cause burns. During and before or after the working process, do not directly touch the machine body with your hands due to the high temperature, especially in high-temperature areas.

13. It is prohibited to use power sources other than the ones indicated on the product label.

14. It is prohibited to use switch knives that do not meet safety standards.

15. It is prohibited to use hard and sharp objects to damage the control panel.
16. When approaching a thunderstorm area, turn off the power switch as early as possible to avoid electrical damage caused by lightning strikes.
17. After finishing the work, turn off the power switch.
18. If the power cord is damaged, to avoid danger, it must be replaced by the manufacturer, its maintenance department or similar full-time personnel.

5. Instruction Manual

1. Before use, it is necessary to check whether the power supply installation is normal and ensure that the power supply voltage matches the operating voltage of the cooker.
2. Turn on the power switch, and the rocker switch light will be on. Then turn the knob to the "ON" position, and the green light will be on. At this point, you can start heating the water in the pasta cooker.
3. Please replenish water in a timely manner during the use process. Keep the liquid level in the cooker below the "maximum liquid level line". It is strictly prohibited to dry-burn the electric heating tube.
4. After use, rotate the gear switch counterclockwise to the "OFF" position and then turn off the power switch.

5. If any abnormal phenomena occur during the use process, you must stop using it immediately. Only after the faults has been checked and eliminated can you continue to use it.

6. Daily Inspection

1. Routine inspections must be carried out frequently.
2. Regularly checking the product can prevent serious accidents from occurring.
3. When you sense a malfunction in the circuit or the machine, you should stop using it.
4. Pay attention to checking the state of the machine before and after using it every day.
5. Is the machine tilted before use?
6. Is the control panel damaged before use?
7. Is the power cord aged, cracked or damaged before use?
8. During use, are there any strange or foul smells, vibrations, sounds, is the temperature out of control or is there any leakage phenomenon?
9. Is the power normal during use?

7. Cleaning and Maintenance

1. When cleaning before use, the power supply must be cut off.
2. After finishing work every day, wipe the product's stove surface and oil pan with a wet cotton cloth. You can use mild degreasing and decontaminating liquids, but avoid using strong acids or alkalis to prevent corrosion damage.
3. Do not use water pipes or high-pressure water to rinse the exterior when cleaning the stove surface or the kitchen. The jet of water may damage the relevant parts of the equipment and affect its normal operation.
4. When cleaning the equipment, do not use cleaning agents containing abrasive substances, tools such as brushes or scrapers to clean the stainless steel surface, as the residual iron filings may cause rusting. Wipe in the satin direction. Do not use products containing chlorine (bleach, hydrochloric acid, etc.) to clean the steel surface, even if these products have been diluted.
5. Do not use corrosive substances (for example: potassium chloride) to clean the floor under the equipment.
6. Whenever the equipment is not in use, turn off the product's control switch and power switch.
7. When it will not be used for a long time, clean the cooker thoroughly, wipe the stainless steel surface with a cloth soaked in gasoline, and then place it in a warehouse with good ventilation and free of corrosive gases.

8. More than 90% of the equipment is made of all metals (stainless steel, iron, aluminum, electroplated metal plates). Therefore, according to the current national standards for the equipment, these metals can be recycled after being processed at designated treatment plants (do not discard them randomly).

Equipment Maintenance Schedule:

Item	Maintenance	Daily	Every 6 months
Body & surface	Clean	○	
Pasta pot	Inspect & clean	○	
Water drain valve	Inspect		*
Angle valve	Inspect		*
Water inlet faucet	Inspect		*
Thermostatic switch	Inspect/replace		*
Temperature limiter	Inspect/replace		*
Heating pipe	Inspect/replace		*
Instruction light	Inspect/replace		*

*** means it must be carried out by qualified professionals.**

8. Fault Analysis and Troubleshooting

Malfunction	Reasons	Troubleshooting methods
Power indicator light is not on.	<ol style="list-style-type: none"> 1. There is no power in the power grid. 2. The indicator light has been damaged. 3. The circuit is open. 	<ol style="list-style-type: none"> 1. There is no power in the power grid. 2. Replace the indicator light. 3. Repair the circuit.
Heating pipe doesn't heat.	<ol style="list-style-type: none"> 1. The heating pipe has been damaged. 2. The circuit is open. <p>The two-position switch has been damaged.</p>	<ol style="list-style-type: none"> 1. Replace the heating tube. 2. Repair the circuit. 3. Replace the two-position switch.
The circuit breaker trips.	<ol style="list-style-type: none"> 1. Short circuit of the circuit. 2. The insulation of the power components is damaged. 	<ol style="list-style-type: none"> 1. Repair the circuit. 2. Strengthen the insulation.

The above malfunction are for reference only. In case of any malfunction, you should stop using it immediately and notify professional technicians to conduct inspection and maintenance as soon as possible! Safety first! Maintenance must be carried out with the power and gas supply turned off.

Please keep this instruction manual carefully for future use!



GGM Gastro International GmbH
Weinerpark 16
D-48607 Ochtrup

www.ggmgaastro.com info@ggmgaastro.com
+49 2553 7220 0