

ggmgastro
INTERNATIONAL

Waffle machine

User manual

WEJ180

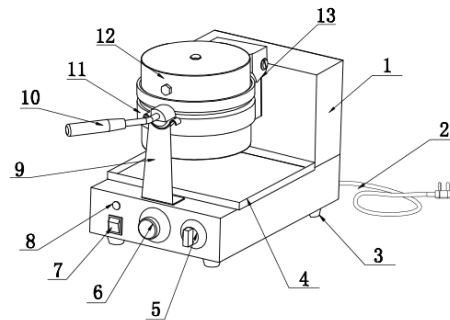

- 1 : Body 2 : Wire 3:Foot 4 : Basin
 5 : Timer 6 : Thermostat 7 : Switch
 8 : Light 9 : Supporting board
 10 : Handle 11 : Down molding board
 12 : Up molding board 13 : Fixing stand

MELJ322

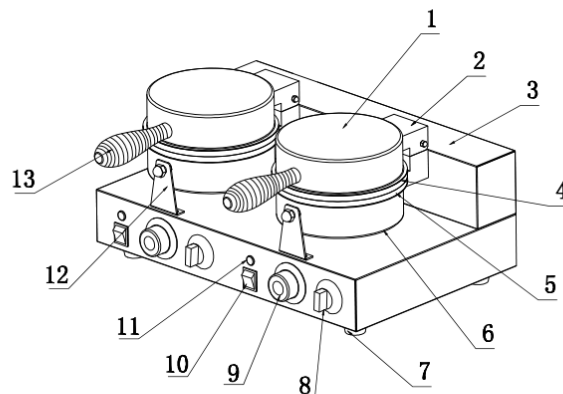

- 1:Up lid 2:Fixing stand 3:Body 4:Up molding board
 5:Down molding board 6:Down lid 7:Foot 8:Timer
 9:Thermostat 10:Switch 11:Light 12:Supporting board
 13:Handle
-

Model	Size (mm)	Voltage(V)	Power(w)	N.W. (KG)
WEJ180	400*250*300	230	1300	9.1KG
MELJ322	500*390*260	230	2600	13KG

Safety precautions:

The following safety precautions must be observed when using this machine:

1. Please read the manual carefully before using the machine.
2. Please don't share the same socket with other high-power electrical appliance so as to avoid over power load or other hazards.
3. The surface of this machine is very hot when the machine is at work or shortly after its being used, so please keep away from the hot part to avoid any burn.
4. Be more careful when using this machine with any children beside! Small children are prohibited from using this machine alone. It must be placed at a location inaccessible to children.
5. This machine must not be used without being taken care of.
6. The power line must not contact any sharp articles or any surface of high temperature so as to prevent it from being damaged.
7. The power line and plug shall be often examined to see if they are damaged. In case of any damage to them, they shall be stopped from being used, and must be repaired or replaced by a professional technician.
8. Don't damage, overly bend, draw or twist the power line. No heavy article shall be placed on it and it must not be clamped.
9. Please turn the temperature controller to "0" and pull out the plug after the machine is used so as to prevent any electric leakage or shock due to the insulation aging.
10. This machine shall be placed at a dry, clean and well-ventilated place. It must be placed horizontally and steadily.

11. The machine must be grounded reliably and the leakage switch shall be properly installed to protect personal safety; otherwise, it must not be used.

12. Please pull out the plug and wait until the machine cools down before moving, inspecting or cleaning it.

13. Don't insert or pull out the switch with a wet hand so as to avoid electric shock hazard.

Notes for the first use

1. Please read the manual carefully.

2. Check if all switches are at the OFF position.

3. Check if the accessories are complete.

4. Please tear off the protective films on the surfaces of the machine and brush away the anti-rust oil with a dry towel.

Notes

1. Transportation and storage

During the transportation, this machine must be handled with care, and must not be placed upside down to prevent any damage to the cover or internal part of the product. The packed hamburger machine shall not be stored in the open air for a long time; instead, it shall be placed in a warehouse with good ventilation but without corrosive gas. In case of temporary storage, proper measures shall be adopted to protect it from rains.

2. Notes for installation

1). The supply voltage must coincide with the service voltage of this equipment.

2). Upon installation, we shall examine whether there is any looseness of all connecting lines, whether the voltage is normal, and whether the safety grounding is reliable.

3). This equipment shall be placed in a steady place, with 10cm away

from any incombustible matters on both sides, while its back shall be 20cm or farther from any incombustible matters, such as wall bricks or windows.

4). The fixed wiring connecting with this equipment must be equipped with an all-pole disconnection switch as per the rule of wiring, and each pole on the switch shall have a contact separation of at least 3mm. It is suggested that an earth leakage circuit breaker should be grounded. No sundries shall be piled in front of the switch to ensure the convenient operation of the switch.

5). No flammable and explosive articles are allowed to be stored near the location of installation. The environmental temperature shall be lower than 45°C, while the relative humidity below 85%.

6). The electrical connection, installation and reparation of this equipment shall be operated by a professional technician.

Special remarks:

1. It is unsuitable for family use; instead, it is a commercial machine which shall be operated by a trained chef.

2. The machine shall not be shook when it is at work, nor shall it be placed slantingly.

3. The machine shall not be disassembled or refit. Any disassembly or refitting of the machine would cause a serious accident.

4. The machine casing shall not be opened. The product contains high-voltage circuits so that there may occur an electric shock accident in case of disassembling the casing.

5. The plug shall be pulled out and the power shut off before cleaning the machine.

6. No jet water course shall be used for cleaning the machine. The water is conductive so that there may occur an electric leakage, which may cause an electric shock accident.

7. The product shall not be patted, and no heavy article shall be placed on it. Abnormal operation will cause damage or hazard to the equipment.

8. High temperature will cause a burn so that you are prohibited from

touching the machine body directly with hands during, before or after the work of the machine.

9. In the event of a thunderstorm, the power connection to the device must be disconnected to prevent damage caused by overvoltage.

10. Hard and sharp articles are prohibited from being used to avoid any damage to the control panel.

11. The switch must be disconnected after the work is over.

12. No inspection operation of the machine shall be conducted by any

personnel other than the qualified maintenance personnel since it is dangerous..

How to bake:

1. Before using the machine, you must examine whether the installation of power supply is normal so as to ensure that the supply voltage coincides with the service voltage of the machine.

2. Please take away any other items before using, especially inflammable goods such as clothes or towel.

3. The machine must be stopped in case of any abnormal condition during the process of using.

4. Turn on the power switch, the green indicator lights up, indicating the electric current is connected with the machine. When we rotate the temperature controller clockwise and align the required temperature scale value with the desired location, the yellow light lights up, indicating that the electrical heating tube is working; when the temperature rises to the required level, the temperature controller can automatically cut off the power supply, when the orange light shuts off, indicating that the electrical heating tube stop working. When the temperature decreases slightly, the temperature controller can automatically switch on and the orange light lights up, indicating the electrical heating tube restarts working, with the temperature climbing again. Such process repeats and recycles to ensure that the temperature is within the constant temperature scope as set.

5. The plate cannot be turned to 360 degrees. You must turn 180 degree to the left and then 180 degree to the right.
6. The timer is just for reminding you. It can not cut off the power.
7. You can adjust the timer to get different color and different flavor products. Normally, it will become deep color with the longer time.
8. The first three pieces of waffle can not be eaten. It taste paste.

Cleaning and maintenance

1. Before and after using the waffle iron, you must clean the baking plates to avoid food residues on them.
2. Before such cleaning, you must shut off the power supply and stop heating. You may do it after it cools down.
3. Upon completion of work every day, you can scrub the surfaces of the machine and the power line with a wet towel which contains no corrosive cleaner before cleaning it with a piece of dry cloth. No jet water course is used for directly washing the machine so as to prevent any water from permeating it and damaging its electrical performance, as well as any accident in association with electricity. It is prohibited to scratch or shovel the heating plate with a hard object.
4. The power switch must be turned off whenever the machine is not in operation.
5. In case of not being in operation for a long period, the plate for pancake must be cleaned and then placed in a warehouse with good ventilation and without corrosive gas.

Breakdowns analysis and fixing

Fault phenomenon	Causes	Elimination methods
The heating indicator light is on, but the temperature does not rise after the power is switched on.	<ol style="list-style-type: none"> 1. The temperature controller has been damaged; 2. The heat generating line has been burnt out. 	<ol style="list-style-type: none"> 1. Replace the temperature controller; 2. Replace the damaged heat generating line.
The heating indicator light is on, but the temperature rise cannot be controlled after switching on and rotating the temperature controller.	<ol style="list-style-type: none"> 1. The temperature controller fails. 	<ol style="list-style-type: none"> 1. Replace the temperature controller.
The heating is normal, but the indicator light is not on after the power is switched on.	<ol style="list-style-type: none"> 1. The indicator light has been damaged. 	<ol style="list-style-type: none"> 1. Replace the indicator light.
The indicator light is not on, nor does it produce any heat.	<ol style="list-style-type: none"> 1. The power supply is abnormal, or the power has not switched on. 2. The fuse has been burned out. 	<ol style="list-style-type: none"> 1. Check the power supply and the connecting lines to see if the power supply is normal. 2. Replace the fuse.

The breakdowns listed above are for reference only. In case of any breakdown, the machine shall be stopped from being used, and a prompt notice shall be dispatched to the professional technician for inspecting and repairing the machine!!!

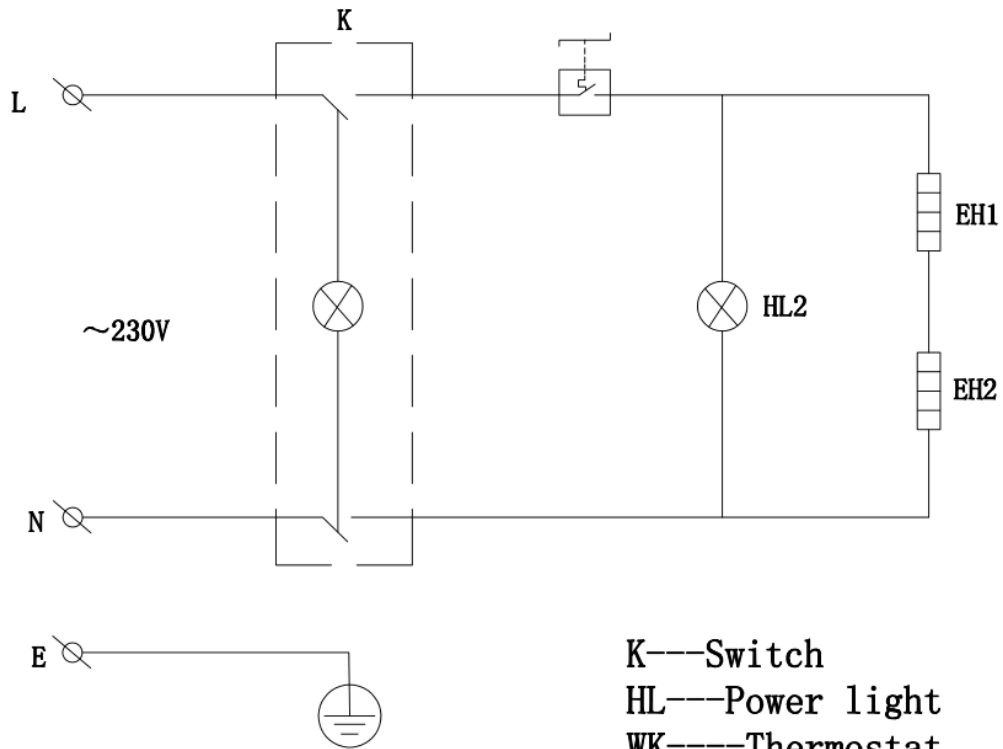

K---Switch
 HL---Power light
 WK---Thermostat
 EH1、EH2---Element

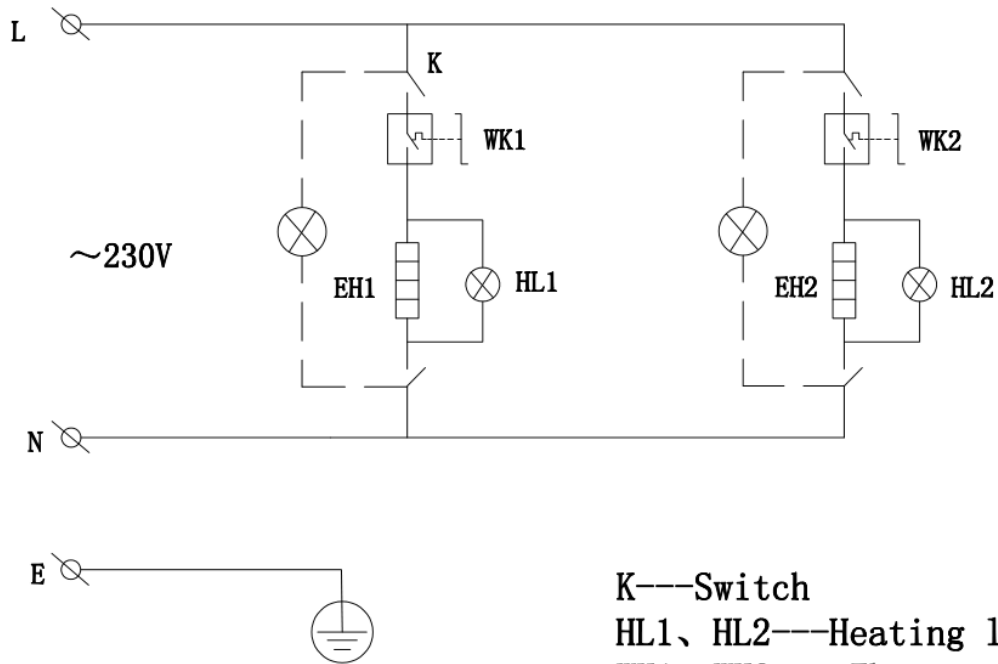

K---Switch
 HL1、HL2---Heating light
 WK1、WK2---Thermostat
 EH1、EH2---Element

Exploded drawing

WEJ180

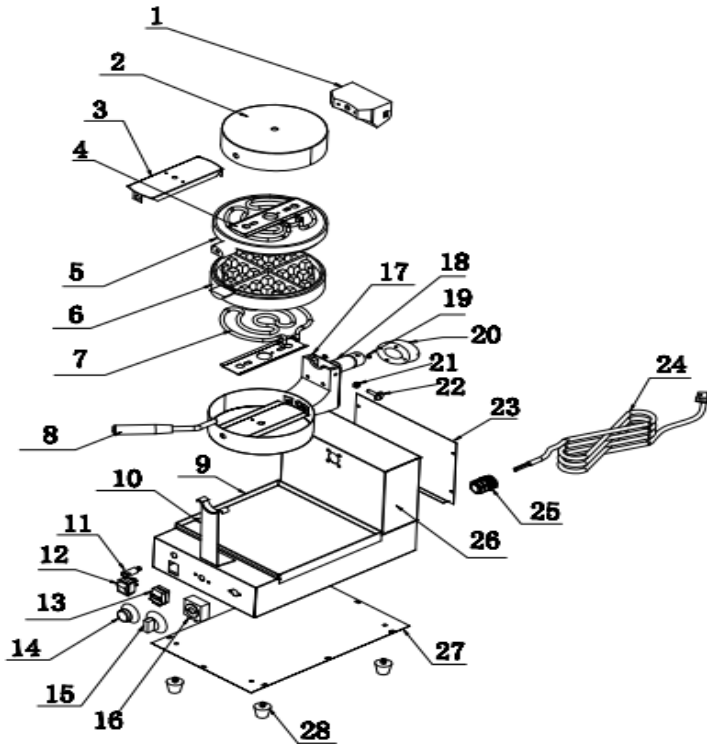

No.	Spare parts name
1	Up aluminum plate
2	Up lid bowl down lid bowl
3	Lid bowl supporting board
4	Element press board
5	Up mold board
6	Down mold board
7	Element
8	Handle
9	Debris basin
10	Support
11	Light (green)
12	Switch (Red)
13	Thermostat
14	knob
15	Timer knob
16	Timer
17	Down aluminum plate
18	Line tube
19	Protector ring
20	Aluminum fixing stand
21	Copper nut
22	Screw
23	Back sealing board
24	Wire
25	Line clamp
26	Base
27	Bottom board
28	Foot

MELJ322

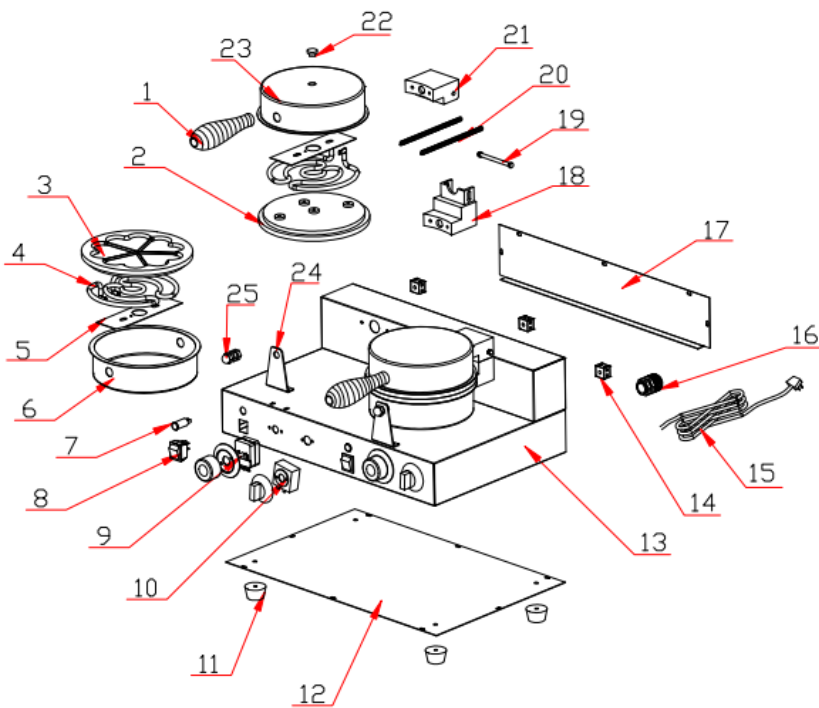

No.	Spare parts name
1	Handle
2	Up molding board
3	Down molding board
4	Element
5	Element press board
6	Down lid
7	Light (green)
8	Switch (Red)
9	knob
	negative
	Thermostat
10	Timer
	Timer knob
11	Foot
12	Bottom sealing board
13	Base
14	Connection terminal
15	Wire
16	Line clamp
17	Back sealing board
18	Down aluminum stand
19	Axle
20	Spring
21	Up aluminum stand
22	Nut
23	Up lid
24	Fixing board
25	Screw

GGM Gastro International GmbH
Weinerpark 16, 48607 Ochtrup
www.ggmgaastro.com