

FWK46-E Chip Heating Instructions Manual

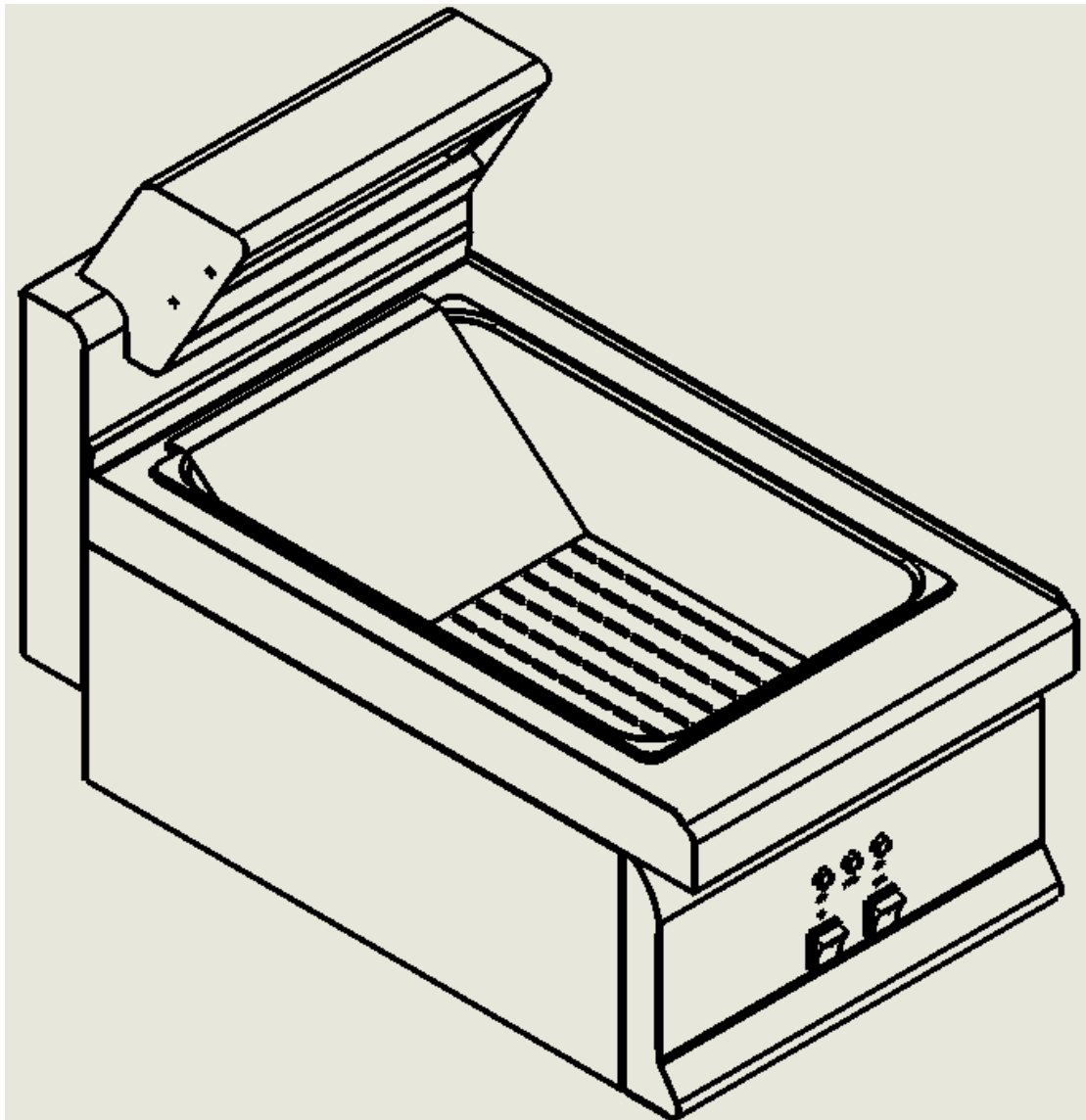

Thank you for choosing our products. Please read the manual instruction carefully before using the equipment and use only as specified.

Attention Owners and Operators

This equipment is designed to provide safe and productive processing, cooking and warming of food products as long as the equipment is used in accordance with the instructions in this manual and is properly maintained. Owners of this equipment bear the responsibility to make certain that this equipment is used properly and safety, and to strictly follow all of the instructions contained in this manual and the requirements of local, state or federal law.

Warning

Improper installation, adjustment, alteration, service or maintenance can cause property damage, injury or death. Read the installation, operating and maintenance instructions thoroughly before installing or servicing this equipment.

For Your Safety

Do not store or use any gasoline or other flammable vapors or liquids in the vicinity of this or other appliance.

1. Parameters

Description	Model	Dimensions	Voltage/ Frequency	Power
Chip heating	FWK46-E	400*600*540	220-240V/50HZ	1.17KW

2. Installation Requirement:

- Please put this equipment on a flat place, and far away from combustible elements.
- Please install proper power switch, fuse and power leakage protector near the equipment.
- The voltage supplied must be consistent with the information in the parameter part above.
- This equipment is connected with fixed wiring, according to the wiring rules and it is equipped with all extremely disconnect switch.
- Repairs should only be performed by qualified technicians to ensure safety. Repairs and other work by unqualified persons could be dangerous. Remove switch components, and the power cord (internal line), the light bulb unit etc, must first stop using; laypeople may not arbitrarily dismantle and modification.

3. Operation Instruction

3.1 Connect the power supply and green power indication lamp will be on.

3.2 Switch on, porcelain heater will be working and keep food warmer.

3.3 After use, please disconnect the power.

4. Daily Checking

Check the appliance before and after use. Before using, make sure the appliance dose not lean. Be certain that the power cord is not worn out or broken. When in use, make sure no unpleasant smell is present and there is no any unusual noise.

Important: Do not discard this manual

This manual is considered to be part of the appliance and is to be given to the owner or manager of the hotel or restaurant, or to the person responsible for training operators of this appliance. It should be retained for future reference. Additional manuals are available from your local dealer.