

03-06-2014

CONTENTS: page

INSTRUCTIONS FOR THE INSTALLER

I.	WARNINGS	2
II.	PRELIMINARY OPERATIONS	2
III.	INSTALLATION AREA	2
IV.	PREPARING FOR INSTALLATION	3
V.	ELECTRICAL CONNECTION	4
VI.	SPECIFICATIONS	7

INSTRUCTIONS FOR THE USER

I.	WARNINGS	8
II.	TESTING	9
III.	ORDINARY MAINTENANCE	9
IV.	EXTRAORDINARY MAINTENANCE	10
V.	MAINTENANCE IN CASE OF BREAKAGE	10
VI.	CONTROL PANEL	10
VII.	ADVICE DURING COOKING	11

INTRODUCTION

Dear customer, thank you and congratulations for buying this appliance; we are confident that this is the beginning of a positive and long-lasting collaboration.

This manual has all the necessary information for the correct use, maintenance and installation of this appliance. The objective of this manual is to enable the technician and user to take all measures and precautions necessary for the safe, efficient, long-term use of the appliance.

Keep this booklet in a safe place, over the entire life cycle of the product for subsequent reference by the operators designated to use and specialized technicians.

Where documents are lost or damaged the replacement documentation must be requested directly from the manufacturer or retailer.

The manufacturer is not held liable for any damage caused by people or things or for inappropriate use of the appliance, modifications or repairs carried out by unauthorized personnel or used with spare parts not recommended by the manufacturer and not intended for use with this model.

This appliance complies with the EEC directives in force.

INSTRUCTIONS FOR THE INSTALLER

I. WARNINGS

Read this instructions booklet carefully before starting the installation and start-up operations.

All installation, assembly, assistance and extraordinary maintenance shall be carried out by qualified personnel and supplied with necessary professional (authorisations by the manufacturer or retailer), in accordance with local laws in effect where installation takes place regarding product and workplace safety.

Incorrect installation, assistance, maintenance, cleaning, tampering or modifications can cause malfunction, damage and breakage.

The appliance must only be used for cooking or heating of foods in industrial kitchens. Any other use is inappropriate and dangerous.

II. PRELIMINARY OPERATIONS

On receipt of the product, make sure it has not been damaged during transport and that the packaging has not been tampered with. In the case of damage or missing parts inform the carrier and retailer/manufacturer immediately, indicating **the code (Art.) and serial number (Ser N°)** and attach a photo.

Check that the installation area is kept clear so that doors, corridors and passageways are accessible.

WARNING: the appliance may fall over during transport leading to breakage and damage to things and people. Use suitable transport capable of taking the weight of the appliance. Do not drag or lean the device for any reason. Lift it up straight from the ground and place horizontally.

III. INSTALLATION AREA

The appliance shall be installed in enclosed and well ventilated areas (not outdoors).

Before positioning the appliance, check the overall dimensions and the exact position of the electrical, water connections.

Make sure that it is placed so that the door may be fully opened.

The appliance is not meant to be fitted and a 5 cm space must be left all round it.

It is not advised to place it near heat, fryers or other hot liquids. If this is not possible at least respect the following distances from machinery: 50 cm from the sides and above the appliance and 70 cm from behind.

Do not place the device near materials or containers of inflammable liquids (such as walls, furniture, screens, gas canisters) as it can be a fire hazard. If this is not possible, cover the inflammable parts with fire and heatproof material and by checking fire hazard regulations.

IV. PREPARING FOR INSTALLATION

Remove the outer packaging (wooden caging and/or carton box) and dispose it in compliance with the laws in force in the country of installation.

REMOVING PROTECTIVE FILM ETC.

Remove the protection film from the external and internal walls. (See image)

Remove all information covering from the inside, and take off all plastic packaging.

STANDS ADJUSTMENT

Do not use the appliance without feet.

Take the feet from inside, raise the device on one side and screw them in the positions shown. They have threaded inserts (see image).

If they are not used, this prevents airflow from cooling the electric parts and outsides of the device which causes over-heating and damage to components.

By placing the appliance flat it will ensure correct functioning. This can be achieved by fitting the stands correctly and using a spirit level.

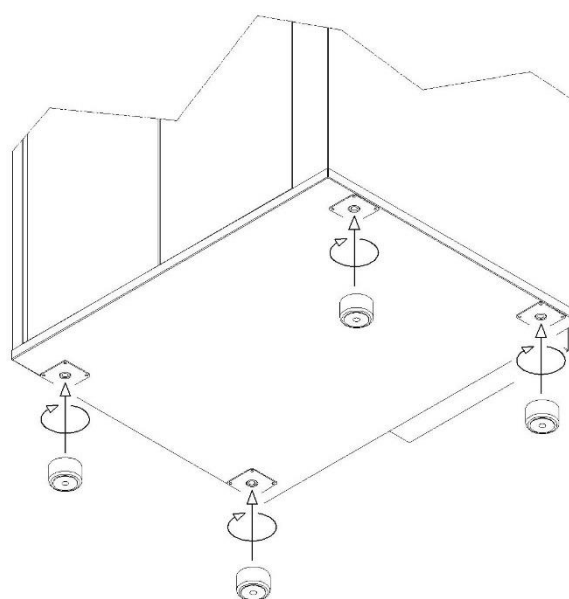
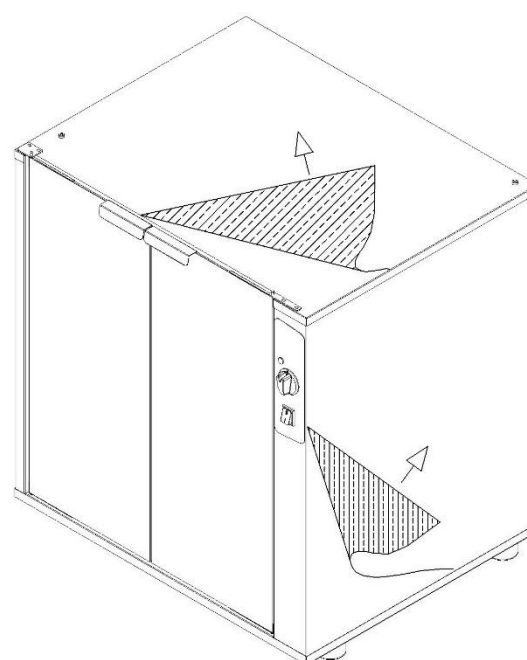

V. ELECTRICAL CONNECTION

WARNING: Main connections must be carried out by a qualified and authorised technician according to national, international and local laws in the country where it is installed.

Before mains connection, ensure that the frequency (.....V) and voltage (....Hz) meet the requirements indicated in the in the information tag on the back of the appliance.

WARNING: if the device does not come with a trolley to facilitate transport, it is advisable to connect it first then place it in position in the work area ensuring the cable is not damaged during placement. This enables easy and safe connection. Ensure that the cable is uniformly exposed to a room temperature no higher than 50°.

PROOFERS WITH CABLE AND SINGLE PHASE PLUGS

For appliance with cable and plug (single phase 220-240V) the plug merely needs to go into the appropriate socket (the socket must be adapted for the supplied plug and must withstand the voltage required by the appliance indicated on the information plate). The product must be positioned so that the plug is always accessible.

The appliance comes with certified cable and plug therefore they must not be tampered with or modified.

Only the cable can be substituted: **this must be carried out by a qualified authorised technician.** The earth wire must always be yellow green.

APPLIANCE NOT SUPPLIED WITH CABLE WITH THREE PHASE TERMINALS

Articles supplied by us come with terminals such as in the image. To connect to the mains see the label in the manual and stuck to the lower part of the back of the appliance near the Information plate.

The device must be connected to the electricity with a rubber cable such as H07RN-F.

WARNING: the yellow/green voltage wires in the earth cable must be 3cm longer than the others.



The device must be connected directly to the mains and must have an easily accessible switch from the start, installed for the device according to the national, international and local laws in the country where it is installed. This switch must separate polarization guaranteeing complete disconnection in accordance with the overvoltage III category.

Correct earthing is obligatory and the earth wire must not be operated by the protection switch.

CABLE CONNECTION

Proceed as follows to connect the power supply wire to the terminal board:

- (A1) Loosen the tops of the cable gland and open the bottom part of the back of the appliance by loosening the screws.
- (A2) Feed the new cable through the cable gland. Connect the cable voltage to the terminal strips following the connection diagram on the label on the back of the appliance. Only connect what is indicated inserting the copper bridge and the electricity cable together under the

screws, in the tightening direction, so the cable and the bridge are tightly fixed by tightening the screw. The type of cable to be used (HO7RN-F) is indicated on the label for each connection and the voltage sections in mm².

- (A4) Close the bottom part of the back of the appliance by tightening the screws and fit the cable by tightening the cable gland top.

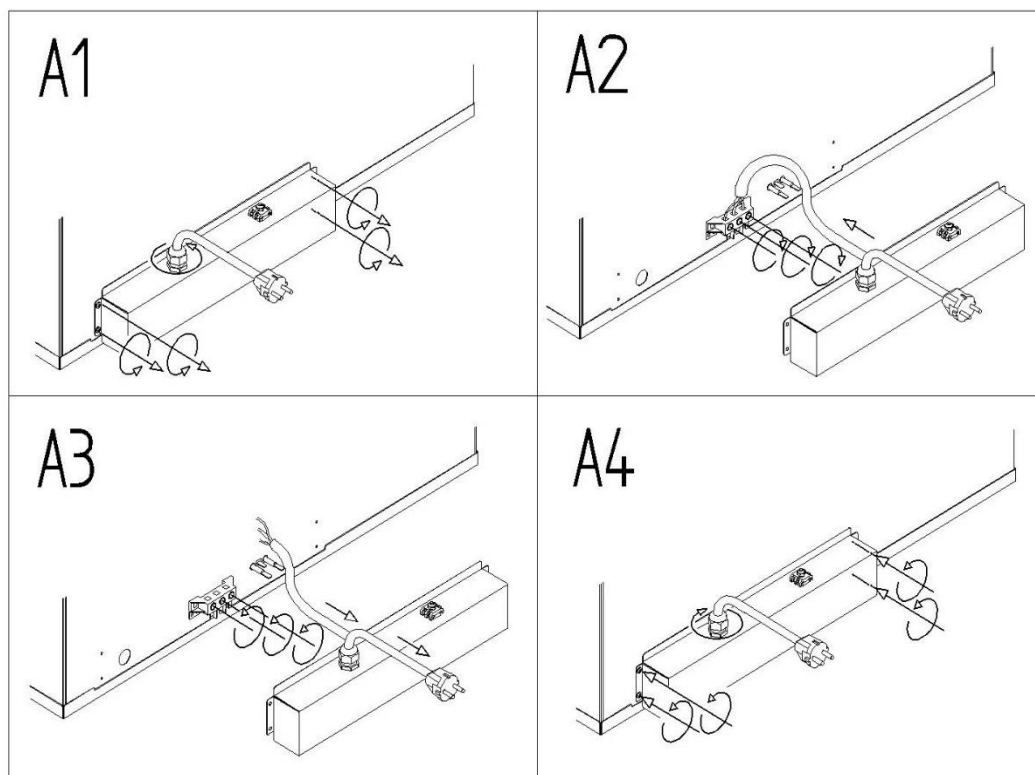
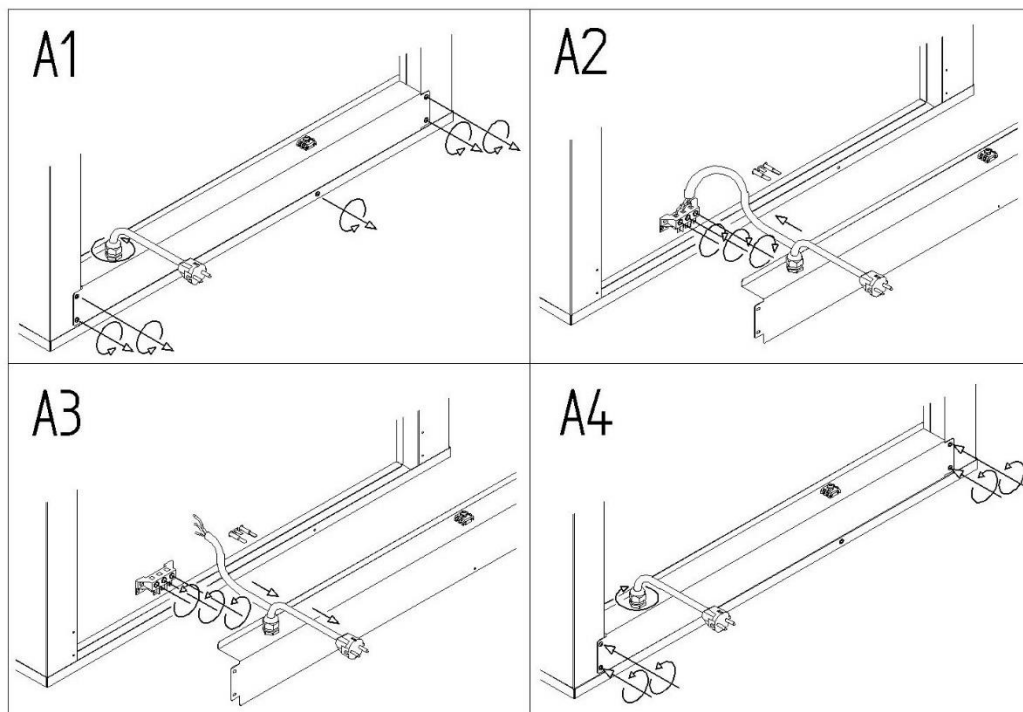

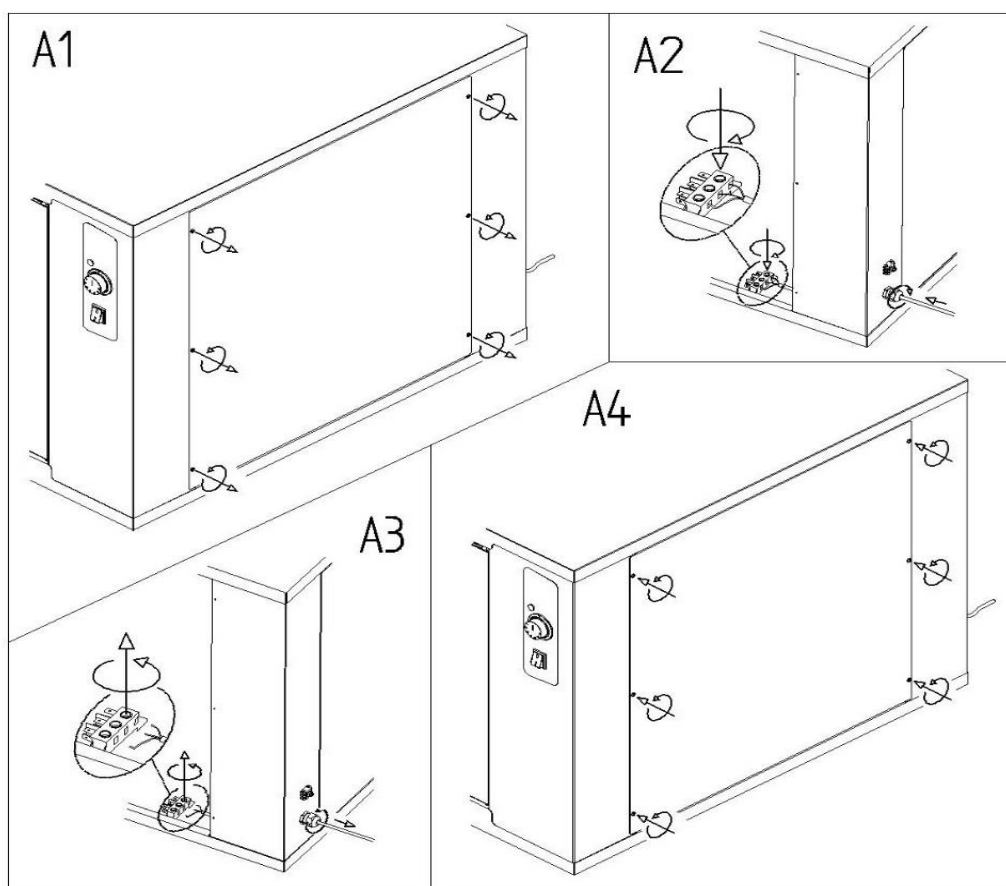

Erroneous connection could lead to overheating of the terminal board which could lead to blowout and electric shock.

Check that all the connections are tight before connecting the device to the mains.

PE = Yellow/Green: “EARTH” protection conductor.

N = Blue: neutral conductor.

L = Brown, Grey, Black: live conductors

Check there is no static discharge between live and earth. Check the limit switch continuity between the external casing and the earth wire of the mains. It is advised to use a multi tester to carry out these operations.

CABLE SUBSTITUTION

This must be carried out by a qualified authorised technician. The earth wire must always be yellow green.

WARNING: the yellow/green voltage wires in the earth cable must be 3cm longer than the others.

Proceed as follows to connect the power supply wire to the terminal board:

- (A1) Loosen the tops of the cable gland and open the bottom part of the back of the appliance by loosening the screws.
- (A3) Loosen the terminal screws and feed the cable conductors through. Take out the old cable from the cable gland.
- (A2) Feed the new cable through the cable gland. Connect the new cable’s conductors to the terminal following the connection diagram on the label at the lower part of the back of the appliance. Only connect what is indicated inserting the copper bridge and the electricity cable

together under the screws, in the tightening direction, so the cable and the bridge are tightly fixed by tightening the screw. The type of cable to be used (H07RN-F) is indicated on the label for each connection and the voltage sections in mm².

- (A4) Close the bottom part of the back of the appliance by tightening the screws and fit the cable by tightening the cable gland top.

Check that all the connections are tight before connecting the device to the mains.

WARNING: Erroneous connection could lead to overheating of the terminal board which could lead to blowout and electric shock.

Check there is no static discharge between live and earth. Check the limit switch continuity between the external casing and the earth wire of the mains. It is advised to use a multimeter to carry out these operations

The appliance must be connected to the mains using a H07RN-F cable.

EQUIPOTENTIAL CONNECTION

This connection shall be carried between the different appliances with the terminal marked by the symbol: (see image). This terminal enables the connection of Yellow/Green cable with a section between 2.5 and 10mm².

The appliance shall be included in an equipotential system whose efficiency shall be duly verified according to the provisions of the laws in force.

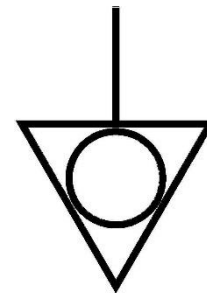

VI. SPECIFICATIONS

INFORMATION PLATE

Art.: P8					
Model.: P8					
Ref.: P85ME010102000					
Ser. N°: 000000000000					
TYPE:					
IPX	kPa:	anno: 2013			
2,0 kW	220-240V	50 Hz			
KG: 0			CE	RoHS MADE IN ITALY	

INFORMATIONS

POWER CONSUMPTION

WEIGHT

SUPPLY

SUPPLY FREQUENCY

Art.:	model according to customer classification
Ref.:	model according to internal manufacturer's classification
Ser. N°:	identification number, different for each product
TYPE:	product model according to its technical properties
Information:	IPX protection level against water sprays / kPa...inflow water pressure / production year.
Power consumption:	appliance nominal power kW
Mains supply:	TERMINAL CONNECTION TYPE: device tension in V, number of phases and neutrals (3N = 3 phases more neutral).
Supply frequency:	appliance frequency in Hz.
Weight:	appliance weight

INSTRUCTIONS FOR THE USER

I. WARNINGS

Read this instructions booklet carefully in that it provides indications regarding safety and use of the appliance.

Keep carefully for reference at all times.

Incorrect installation, assistance, maintenance, cleaning, tampering or modifications can cause malfunction, damage and breakage.

The proofer cabinet must only be used for proofing of foods in industrial and professional kitchens. Any other use is inappropriate. The manufacturer is not liable where it is used inappropriately.

The appliance is intended for professional use and it shall be used by qualified personnel.

The appliance is not suitable for use by people with low physical or mental abilities or lacking experience, unless instructed regarding the operation of the device by the personnel in charge of safety their safety.

Do not leave the appliance unattended in presence of children and ensure that the latter do not have access to the appliance.

It is thus strongly recommended not to position sources of heat near the appliance.

Do not under any circumstance, leave flammable material near appliance: it can be a fire hazard.

Food container temperatures, accessories or other objects can be very hot; beware of burns when moving them. Only touch them with relevant thermal protection. Scald danger!

Use fingers to regulate the digital panel options; any other object may damage the device hence nullify the validity of the warranty.

Damage or breakage of door glass components must be substituted immediately (contact the Assistance Centre). If it is not in use for long periods of time (many days) it is advisable to turn it off at the mains. The producer shall not be deemed liable for any damage incurred by persons or properties, caused by non compliance with the aforementioned instructions of deriving from tampering with even a single part of the appliance and use of non-genuine spare parts. This appliance complies with the EU directives in force.

II. TESTING

Make sure all checks required to ascertain strict adherence with the soundness of the systems and the installation of the appliance with the law regulations as well as technical and safety instructions provided for by this manual are as well carried out before operating the appliance.

There should not be plastic bags inside it, instruction manuals, plastic film or anything else.

All packaging should have been entirely removed, including the protective film applied on the walls of the product purchased.

Check every item in the list below:

On reaching the set temperature, the cooking temperature thermostat turns off the heating elements.

FIRST CLEANING OF THE COOKING CHAMBER

Disconnect electrical power from the appliance and wait until the device is cooled completely before cleaning.

WARNING: the appliance should never be cleaned with high pressure water sprays.

There should never be any residue of solvents or detergents. They should be removed by rinsing thoroughly using a damp cloth. Appropriate eye, mouth and hand protection should be used. Possible danger of corrosion.

Clean the walls of the proofer chamber using hot water and soap, then rinse; never use aggressive or acid products.

III. ORDINARY MAINTENANCE

The user is solely responsible for ordinary maintenance. The Assistance Centre must be contacted for extraordinary maintenance which requires a specialised authorised technician.

ORDINARY CLEANING OF COOKING CHAMBER CLEANING

Disconnect electrical power from the appliance and wait until the oven is cooled completely before cleaning.

At the end of a working day, clean the equipment, both for hygienic reasons and to avoid malfunctioning.

The proofer must never be cleaned using direct or high pressure water jets. In the same manner, to clean the appliance do not use pan-scrubbers, steel brushes or scrapers; it is possible to use stainless steel wool, rubbing it in the direction of the sheets satin finish.

Wait for the cooking compartment to cool down.

Remove the side tray racks.

Manually remove all removable residues place the removable parts inside dishwashers.

To clean the cooking compartment use soapy warm water. Subsequently, all surfaces must be thoroughly rinsed, being careful to ensure no detergent residues remain.

Only use products recommended by the manufacturer of the appliance.

EXTERNAL CLEANING

Only use a damp cloth with warm water or products suitable for cleaning stainless steel. Do not use acidic products or ammonia.

WARNING: the appliance should never be cleaned with high pressure water sprays.

IV. EXTRAORDINARY MAINTENANCE

It is advisable to have the appliance subjected to periodical checks (at least once per year) by a specialised authorised technician.

Any maintenance, installation or repair work must be carried out by qualified authorised personnel by contacting the Assistance Centre. Before carrying out any operation the appliance must be plugged out at the mains, turn off the water mains taps and wait for it to cool down.

Before moving the appliance from position, check that the electricity and water connections (electric cables water pipe and drainage) are correctly plugged out.

If the appliance is on wheels check that electric cables, pipes or anything else are not damaged while moving it. Ensure the break is on. Avoid placing the device near heat (such as fryers etc.). After carrying out the task and replacing the appliance in its initial position, check that the electric and water are connected correctly.

V. MAINTENANCE IN CASE OF BREAKAGE

If the appliance breaks, disconnect it from the mains and turn off water.

Before ringing Customer Service, check the chart below).

PROBLEM	CAUSE	SOLUTION
The leavening cabinet isn't heating	Supply voltage failure	Restore power supply voltage
	Incorrect connection to the power supply network	Check connection to the power supply network
	Broken resistance	Contact specialised technician for repair (Assistance Service).
	Broken thermostat of temperature	Contact specialised technician for repair (Assistance Service).

If the problem persists we advise you to consult a retailer or manufacturer asking for Assistance Service specifying the problem and supplying your **code (Art.) and serial number (Ser N°)**. This information is provided on the INFORMATION PLATE on the back of the machine.

SPARE PARTS

Use only authorized parts for product repair. All interventions shall be carried out by authorized and specialized technical personnel. Contact the Assistance Centre to request spare parts.

VI. CONTROL PANEL

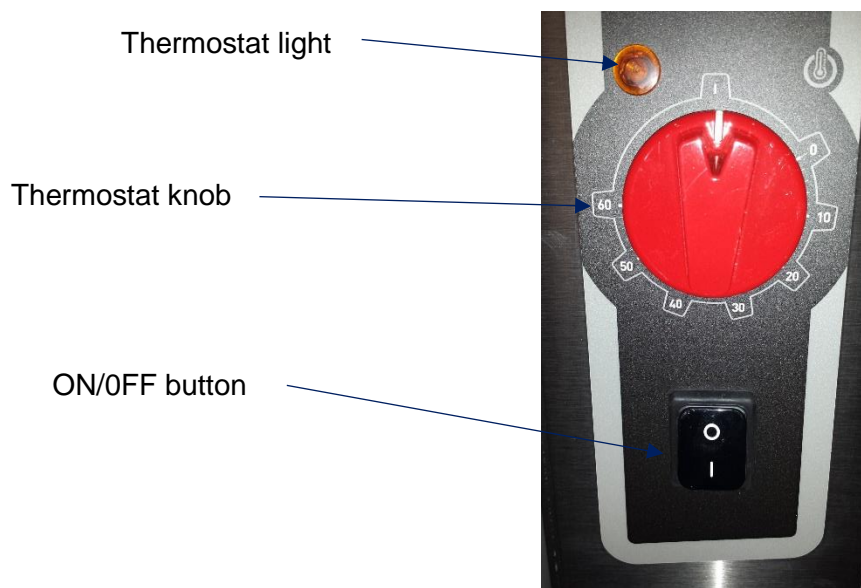

- **ON/OFF BUTTON**

This button turn the the leavening cabinet on and off.

- **THERMOSTAT KNOB**

This knob allows selecting the desired coking temperature.

- **THERMOSTAT LIGHT**

When the heating elements are lit they are on because the internal leavening cabinet temperature is less than the set by the thermostat value dial. When the light goes off it means that the inside of the leavening cabinet has reached the set temperature.

VII. ADVICE DURING COOKING

Press ON/OFF and turn the temperature dial to the desired value.

HUMIDIFIER

For proofing or to conserve any food, fill the container at the bottom of the proofer cabinet with water and turn on the appliance, setting the desired temperature. The water will become steam thanks to the heating of components on the underside of the container.