

Esploso Forno Best For 523

Exploded View Best For 523

Particolare
Single Item

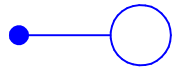

Kit

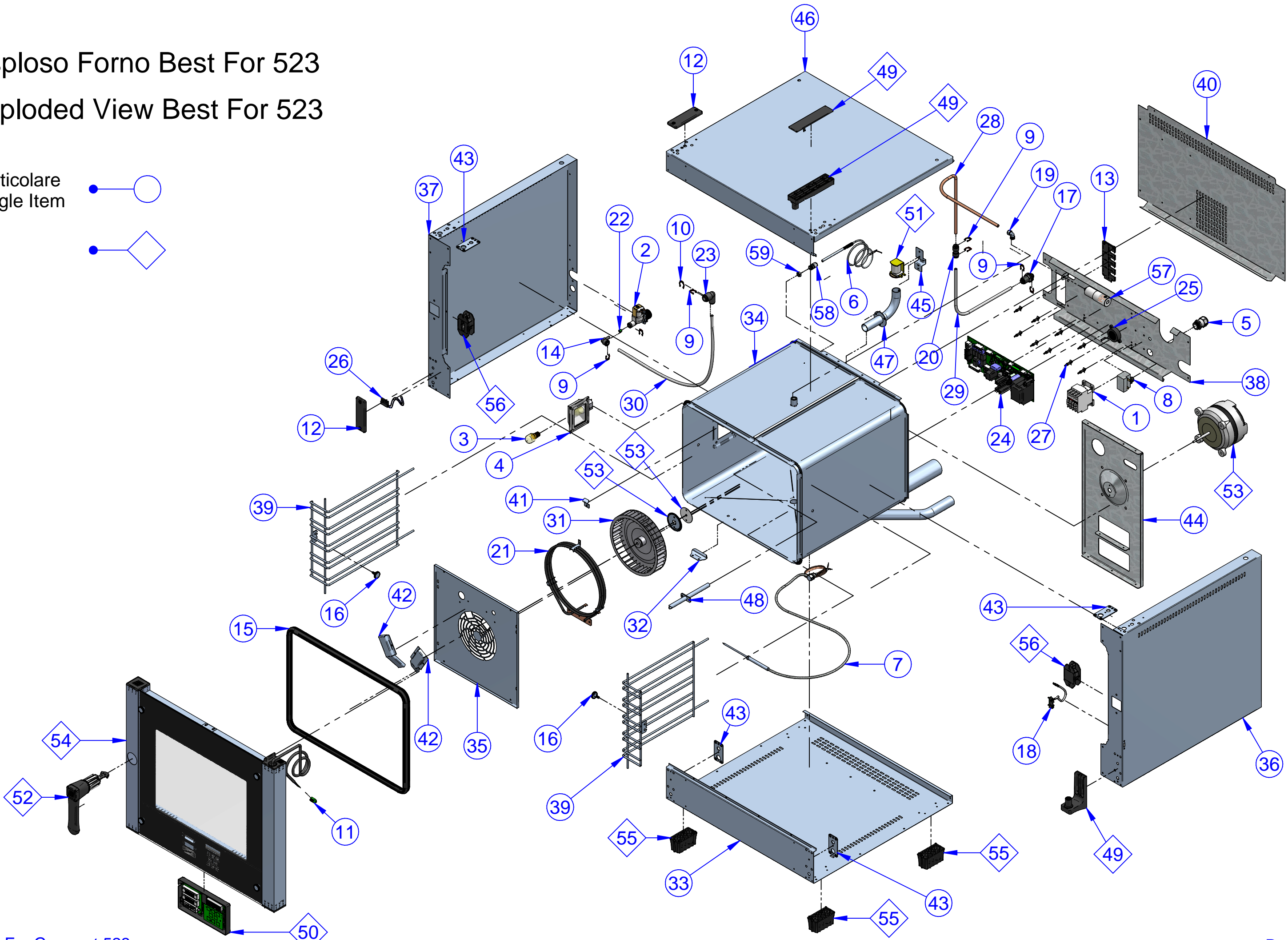
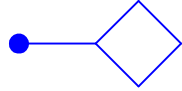

Particolare Impianto Idrico 523

Water System 523

Particolare
Single Item

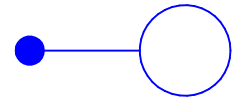

Kit

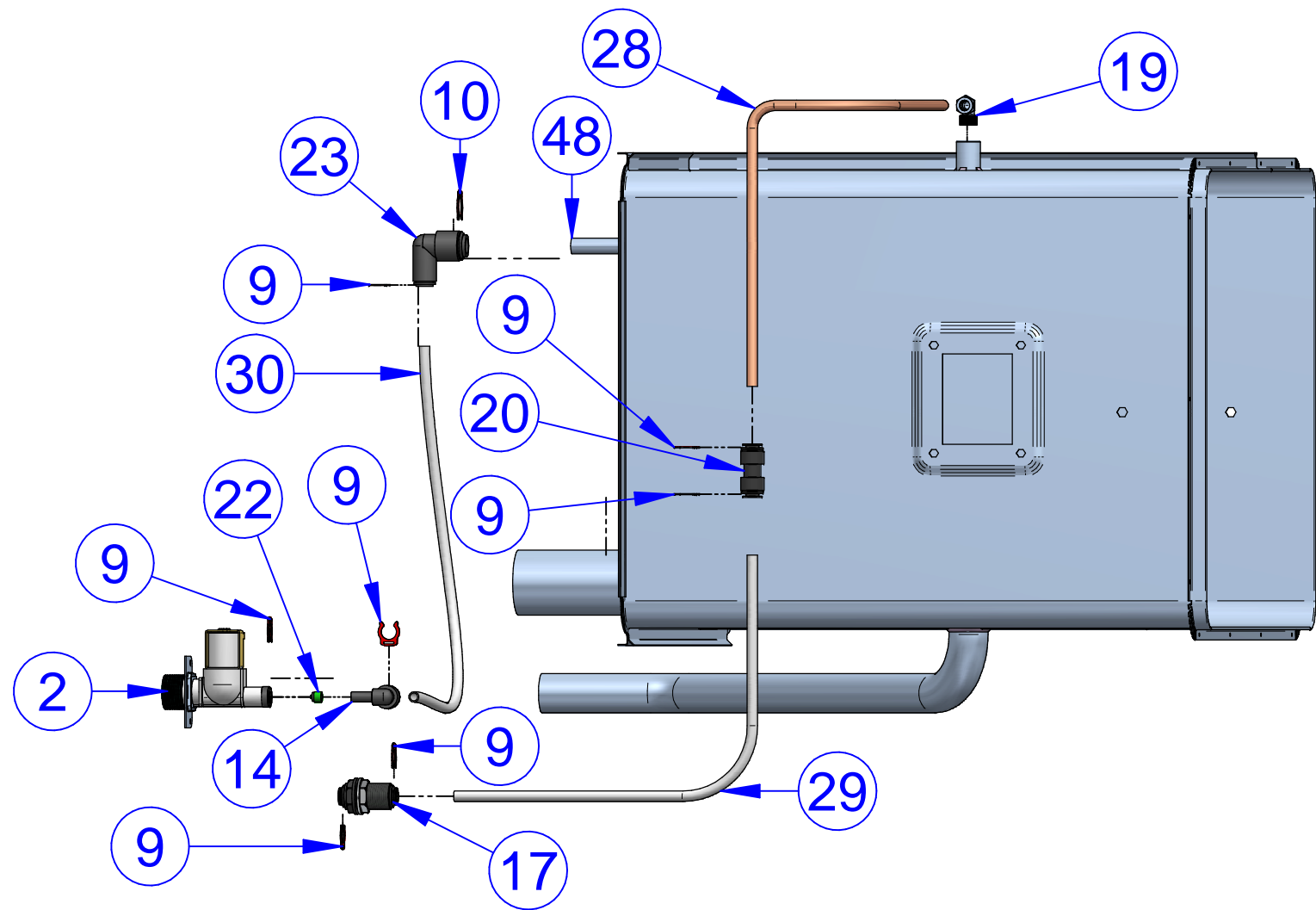
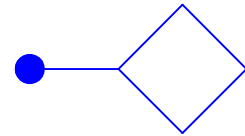

Componenti Pannello Elettrico e Centralina 523

Back Power Panel and Front Control Panel 523

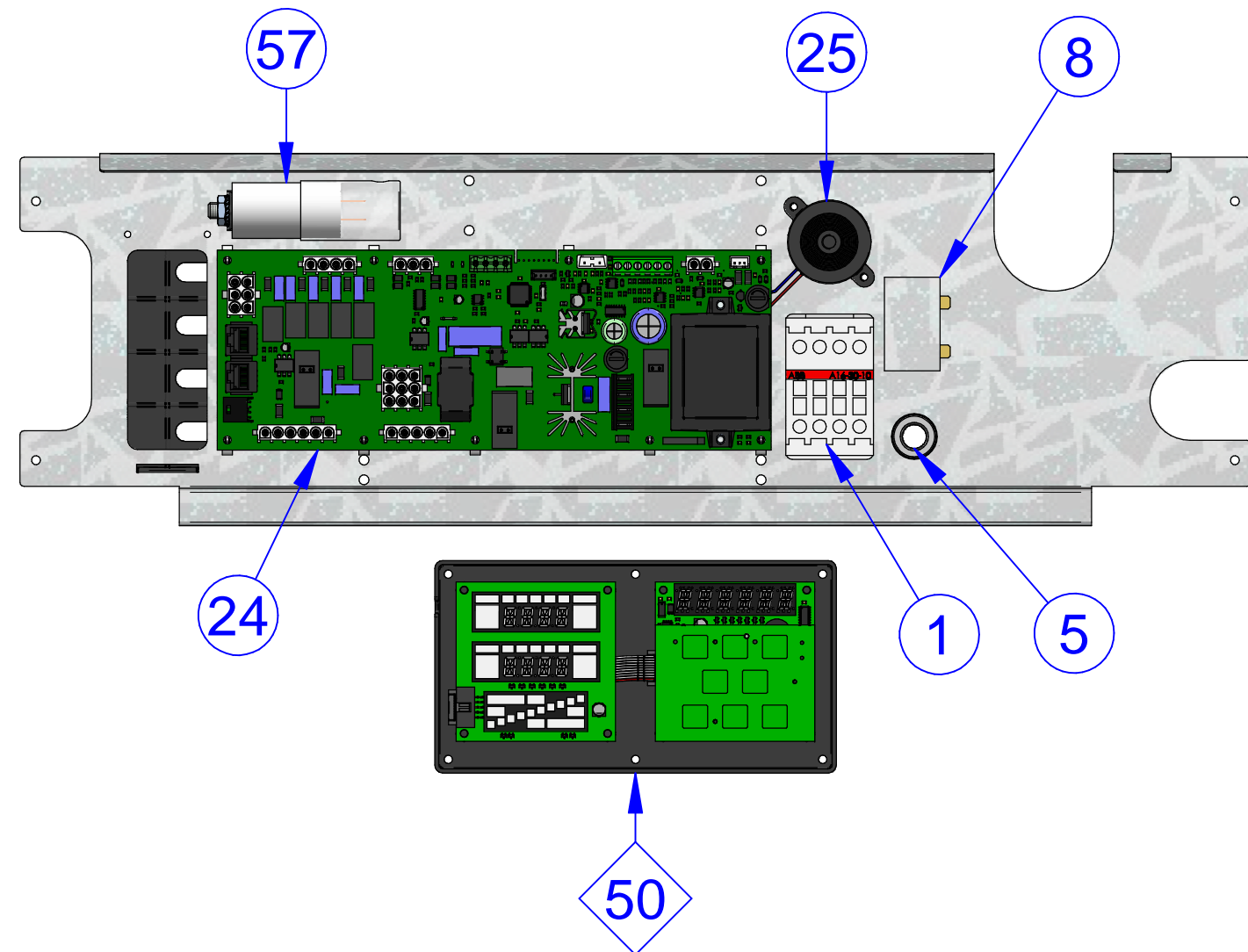

Esploso Kit Porta Completa 523

Door Kit Best For 523 Exploded View

Particolare
Single Item

Kit



Tabella Componenti Forno 523

N	Codice	Titolo	Description	Descripció	Descriptiò	Beschreibung	Q
1	113007020	Teleruttore ABB A16-30-10	Remote control switch ABB A16-30-10	Telerruptor ABB A16-30-10	Télerupteur ABB A16-30-10	Fernschalter ABB A16-30-10	1
2	120800011	Elettrovalvola 230V 1 Uscita JG Ruotata	Solenoid valve 230V 1 JG turned outlet	Electroválvula 230V 1 Salida JG rotada	Électrovanne 230V 1 Sortie JG pivotante	Magnetventil 230V 1 Ausgang JG Gedreht	1
3	146600013	Lampadina 23 W 240 V 300°	23W 240V 300° la mp	Bombilla 23W 240V 300°	Lampe 23W 240V 300°	Leuchte 23W 240V 300°	1
4	166400010	Lampada Bistrot Completa	Complete Bistrot lamp	Bombilla Bistrot completa	Lampe Bistrot complète	Komplette Leuchte Bistrot	1
5	166900002	Pressacavo PG16	Cablegland PG 16	Prensacables PG 16	Serre-câble PG 16	Kabelverschraubung PG 16	1
6	179600000	Sonda Jota Giunto Isolato 6x100 Cavo 1,5m	Insulated Jota joint probe 6x100 Cable 1.5m	Sonda Jota junta aislada 6x100 cable 1,5m	Sonde Jota joint isolé 6x100 Câble 1,5m	Fühler Jota isolierte Verbindung 6x100 Kabel 1,5m	1
7	179607520	Sonda Al Cuore SP G B 10 4 KKG 30.8 N N	Core probe SP G B 10 4 KKG 30.8 N N	Sonda aguja SP G B 10 4 KKG 30.8 N N	Sonde à cœur SP G B 10 4 KKG 30.8 N N	Kernfühler SP G B 10 4 KKG 30.8 N N	1
8	182500029	Termostato di Sicurezza 16A 250V t335° CT150	Safety thermostat 16A 250V t335° CT150	Termostato de seguridad 16A 250V t335° CT150	Thermostat de sécurité 16A 250V t335° CT150	Sicherheitsthermostat 16A 250V t335° CT150	1
9	312000020	Clip Blocca Pinzetta 8 JG PMC1808R	8 JG Pliers Locking Clip PMC1808R	Clip bloqueo pinza 8 JG PMC1808R	Clip 8 JG PMC1808R	Klammer Pinzettenbefestigung 8 JG PMC1808R	7
10	312000021	Clip Blocca Pinzetta 12 JG PIC1816R	12 JG Pliers Locking Clip PIC1816R	Clip bloqueo pinza 12 JG PIC1816R	Clip 12 JG PIC1816R	Klammer Pinzettenbefestigung 12 JG PIC1816R	1
11	313007020	Connettore Per Cavo D-P CNC PF04D1FF00	Connector for cable D-P CNC PF04D1FF00	Conector para cable D-P CNC PF04D1FF00	Connecteur pour câble D-P CNC PF04D1FF00	Steckverbinder für Kabel D-P CNC PF04D1FF00	1
12	313207025	Coperchio Fori Cerniera	Hinge slot cover	Tapa orificios bisagra	Couvercle orifices charnière	Abdeckung Scharnierbohrungen	2
13	313207030	Coperchio Prese Aux Centralina	Control unit aux socket cover	Tapa tomas aux centralita	Couvercle prises aux. de la centrale	Abdeckung zusätzl. Steckdosen Steuereinheit	1
14	331300020	Gomito con codolo JG 8-8 PM220808E	Elbow with shank JG 8-8 PM220808E	Codo JG 8-8 PM220808E	Coude à cône JG 8-8 PM220808E	Bogen mit Schaft JG 8-8 PM220808E	1
15	331807020	Guarnizione Camera	Chamber gasket	Junta cámara	Joint chambre	Abdichtung Garraum	1
16	351600007	Manopola Zigrinata M5	Knurled knob M5	Mando estriado M5	Manette crénelée M5	Rändeldrehknopf M5	2
17	363600000	Passaparete Intermedio JG 8mm PM1208E	Intermediate coupling JG 8mm PM1208E	Pasa-pared intermedio JG 8mm PM1208E	Passe-mur intermédiaire JG 8mm PM1208E	Mittlerer Wanddurchlass JG 8mm PM1208E	1
18	366907020	Prolunga Connettore Seriale PH003_A01	USB logger interface	Interfaz USB Logger	Interface USB logger	USB-Schnittstelle Logger	1
19	373000002	Raccordo a L D.8 1-4	L-shaped fitting D.8 1-4	Rácor en L D.8 1-4	Raccord en L D.8 1-4	L-förmiger Anschluss D.8 1-4	1
20	373000021	Raccordo intermedio Dritto 8-8 JG PM0408E	Straight intermediate fitting 8-8 JG PM0408E	Rácor intermedio recto 8-8 JG PM0408E	Raccord intermédiaire droit 8-8 JG PM0408E	Gerader Zwischenanschluss 8-8 JG PM0408E	1
21	373500041	Resistenza Bistrot 464 230V 3100W	Bistrot 464 heating element 230V 3100W	Resistencia Bistrot 464 230V 3100W	Résistance Bistrot 464 230V 3100W	Heizwiderstand Bistrot 464 230V 3100W	1

Tabella Componenti Forno 523

N	Codice	Titolo	Description	Descripcìon	Descriptiòn	Beschreibung	Q
22	374000008	Riduttore Di Portata Verde 0,25 L-min	Flow reducer green 0,25 lt-min	Reductor de flujo verde 0,25 lt-min	flux réducteur vert 0,25 lt-min	Grüner Zuflussuntersetzer 0,25 lt -min	1
23	374000020	Riduzione a Gomito JG 12/8 PM211208E	Elbow adaptor JG 12/8 PM211208E	Codo reductor JG 12/8 PM211208E	Raccord coudé de réduction JG 12/8 PM211208E	Bogenreduzierung JG 12/8 PM211208E	1
24	378607020	Scheda Di Potenza PJ082_A01	Power board PJ082_A01	Tarjeta de potencia PJ082_A01	Carte de puissance PJ082_A01	Leistungskarte PJ082_A01	1
25	379200000	Segnalatore acustico nero	Black acoustic indicator	Avisador acústico negro	Avertisseur sonore noir	Summer schwarz	1
26	379206500	Sensore MK21-1A71C1000W	Sensor MK21-1A71C1000W	Sensor MK21-1A71C1000W	Capteur MK21-1A71C1000W	Fühler MK21-1A71C1000W	1
27	381000003	Supporto Plastica MPDSDST2SIY00 8mm	Plastic support MPDSDST2SIY00 8mm	Soporte plástico MPDSDST2SIY00 8mm	Support en plastique MPDSDST2SIY00 8mm	Kunststoffhalterung MPDSDST2SIY00 8mm	9
28	385500002	Tubo in rame D. 8	Copper pipe D. 8	Tubo en cobre 8	Tuyau en cuivre D. 8	Kupferrohr D. 8	1
29	385500020	Tubo Pe Trasparente JG 8x6 PE-006-100M-N	Transparent PE Pipe JG 8x6 PE-006-100M-N	Tubo Pe trasparente JG 8x6 PE-006-100M-N	Tube Pe transparent JG 8x6 PE-006-100M-N	Transparenter PE-Schlauch JG 8x6 PE-006-100M-N	1
30	385500020	Tubo Pe Trasparente JG 8x6 PE-006-100M-N	Transparent PE Pipe JG 8x6 PE-006-100M-N	Tubo Pe trasparente JG 8x6 PE-006-100M-N	Tube Pe transparent JG 8x6 PE-006-100M-N	Transparenter PE-Schlauch JG 8x6 PE-006-100M-N	1
31	391500015	Ventola Pale Dritte VE14484 D.200x43	Straight blade fan VE14484 Diameter 200x43	Ventilador palas rectas VE14484 Diámetro 200x43	Vanne à pales droites VE14484 Diamètre 200x43	Geblase gerade Schaufeln VE14484 Durchmesser 200x43	1
32	502604433	Alloggiamento sonda al cuore	housing core probe	Vivienda sonda aguja	Logement sonde à cœur	Kernfühlergehäuse	1
33	505604433	Basamento	Base	Base	Base	Unterteil	1
34	510604433	Camera Di Cottura	Cooking chamber	Cámara de cocción	Chambre de cuisson	Garraum	1
35	513104433	Convogliatore Aria	Air conveyor	Direccionador aire	Convoyeur d'air	Luftführung	1
36	546604433	Laterale Destro	Right side	Lateral derecho	Latéral droit	Rechte Seite	1
37	546604435	Laterale Sinistro	Left side	Lateral izquierdo	Latéral gauche	Linke Seite	1
38	563704433	Pannello Impianto Elettrico	Electrical system panel	Panel instalación eléctrica	Panneau installation électrique	Anlagentafel	1
39	566504523	Portateglie GN 2/3	Pan support GN 2/3	Portabandejas GN 2/3	Porte-plats GN 2/3	Blechhalter GN 2/3	2
40	573604433	Retro Forno	Oven Back	Trasera horno	Arrière four	Ofenrückseite	1
41	580306021	Squadretta Spruzzatori	Spray nozzle bracket	Escuadra rociadores	Équerre vaporisateurs	Winkelplatte Sprühdüsen	1
42	580306500	Squadretta spruzzatore	Spray nozzle bracket	Escuadra rociador	Équerre vaporisateur	Winkelplatte Sprühdüse	2
43	581007030	Supporto\Rinforzo Cerniera	Hinge support/reinforcement	Soporte/refuerzo bisagra	Support\Renforcement de la charnière	Scharnierhalterung\Verstärkung	4
44	581104433	Supporto Motori	Motor support	Soporte motores	Support moteurs	Motoren halterung	1
45	581107021	Supporto Attuatore Aria	Air actuator support	Soporte actuador aire	Support actionneur d'air	Halterung Luftantrieb	1
46	582604433	Tetto	Top panel	Techo	Toit	Abdeckung	1

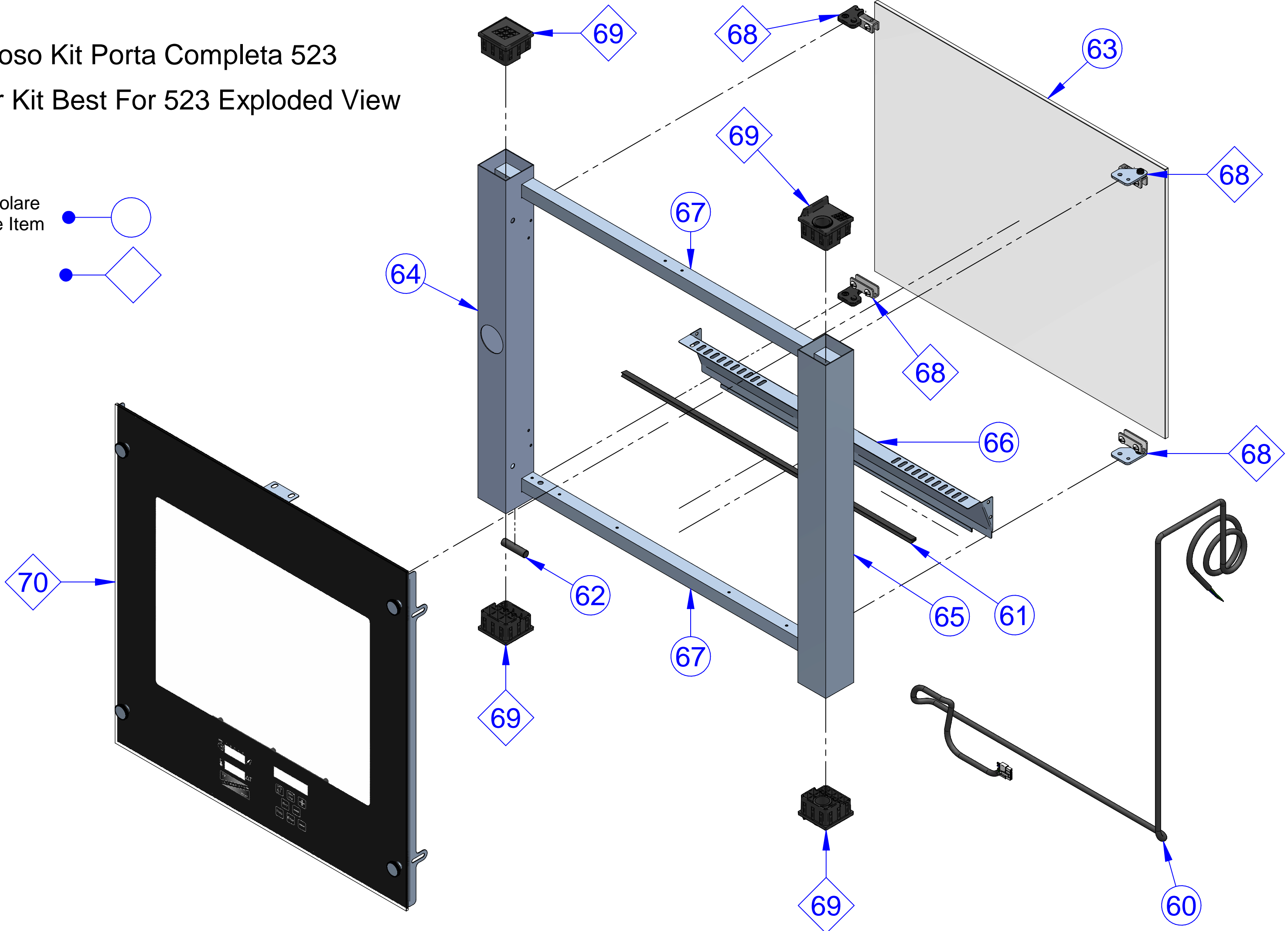
Tabella Componenti Forno 523

N	Codice	Titolo	Description	Descripcìon	Descriptiòn	Beschreibung	Q
47	585504433	Tubo Ingresso Aria	Air inlet pipe	Tubo entrada aire	Tuyau d'entrée de l'air	Lufteintrittsrohr	1
48	585504435	Tubo Ingresso Acqua	Water inlet pipe	Tubo entrada agua	Tuyau d'entrée de l'eau	Wassereinlaufrohr	1
49	711007030	Kit Cerniere Porta Serie Star	Door hinge Serie Star Kit	Kit Bisagra puerta Serie Star	Kit charnière porte Serie Star	Türscharnier Kit Serie Star	1
50	715707021	Kit Centralina Frontale Serie Star Orizzontale	Front Control unit Serie Star Kit (horizontal)	Kit Frontal centralita Serie Star (horizontal)	Kit Frontal centrale Serie Star (horizontale)	Vorderseitiges Steuerneinheit-Kit Serie Star (waagrecht)	1
51	734600003	Kit Attuatore	Actuator Kit	Kit Actuador	Kit Actionneur	Kit Antrieb	1
52	751607900	Kit Maniglia Serie Star	Handle Serie Star Kit	Kit Tirador Serie Star	Kit Poignée Serie Star	Griff Kit Serie Star	1
53	753000030	Kit Motore K48210 Serie Star	Motor Kit K48210 Serie Star	Kit Motor K48210 Serie Star	Kit Moteur K48210 Serie Star	Motor Kit K48210 Serie Star	1
54	753104433	Kit Porta Completa 523 Serie Star	Complete door 523 Serie Star Kit	Kit Puerta completa 523 Serie Star	Kit Porte complète 523 Serie Star Kit	Komplettes Tür 523 Serie Star Kit	1
55	764507020	Kit 4 Piedini di Supporto Forno	Oven 4 feet kit	Kit 4 Patas soporte	Kit 4Pieds de support	Kit 2 Ofenstützfüße	1
56	779207030	Kit Serrature in Plastica	Plastic lock Kit	Kit Cerradura de plástico	Kit Serrure en plastique	Schlösserkit aus Kunststoff	1
57	Commerciale	Condensatore 5mF Ducati Energia	Condenser 5mF Ducati Energia	Condensador 5mF Ducati Energia	Condensateur 5mF Ducati Énergie	Kondensator 5mF Ducati Energie	1
58	Commerciale	Raccordo Porta Sonda Jota	Jota probe holder fitting	Rácor portasonda Jota	Raccordo porte sonde Jota	Anschluss Türfühler Jota	1
59	Commerciale	Dado 1/8 Gas Inox	Nut 1/8 gas inox	Tuerca 1/8 gas inox	Écrou 1/8 gaz inox	Mutter 1/8 gas inox	1

Tabella Componenti Kit Porta Completa 523

N	Codice	Titolo	Description	Descripcìon	Descriptiòn	Beschreibung	Q
60	310507020	Cavo Collegamento Display-Potenza CB04V4000MKZZ	Display-Power connection cable CB04V4000MKZZ	Cablo conexión pantalla-potencia CB04V4000MKZZ	Câble de branchement écran-Puissance CB04V4000MKZZ	Anschlusskabel Display-Leistung CB04V4000MKZZ	1
61	331800010	Guarnizione Vetro-centralina	Glass-control unit gasket	vidrio-centralita junta	vitre-centrale joint	Abdichtung Steurereinheitsglas	1
62	351600008	Magnete Micro Porta	Door micro magnet	Imán microinterruptor puerta	Aimant micro porte	Türmikromagnet	1
63	391604435	Vetro Interno	Internal glass	Vidrio interno	Vitre interne	Innenglas	1
64	553104433	Montante Porta Lato Maniglia Plastica	Door upright on plastic handle side	Montante puerta lado tirador plástico	Montant porte côté poignée en plastique	Türholm Kunststoffgriffseite	1
65	553104435	Montante Porta Lato Cerniere	Door upright on hinge side	Montante puerta lado bisagras	Montant porte côté charnière	Türholm scharnierseitig	1
66	578704433	Schermo Protezione Centralina	Control unit protection screen	Pantalla protección centralita	Écran de protection de la centrale	Schutzabdeckung Steuereinheit	1
67	584504433	Traversa Porta	Door cross-piece	Travesaño puerta	Barre porte	Querstrebe der Tür	2
68	712007020	Kit Montaggio Vetro Interno Serie Star	Assembly inner Glass Serie Star Kit	Kit Montaje vidrio interno Serie Star	Kit Assemblée vitre interne Serie Star	Montage Kit inner Glases Serie Star	1
69	782007020	Kit Tappi Porta Serie Star	Door plugs Serie Star Kit	Kit Tapón puerta Serie Star	Kit Cache porte Serie Star	Türabdeckkappe Kit Serie Star	1
70	791604523	Kit Vetro Esterno Gourmet 523	Outer glass Gourmet 523 Kit	Kit Vidrio externo Gourmet 523	Kit Vitre externe Gourmet 523	Kit Außenglas Gourmet 523	1