

Kit Porta Completa BL511 80P

Complete Door Kit BL511 80P

Particolare
Single Item

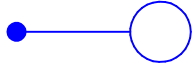

Kit

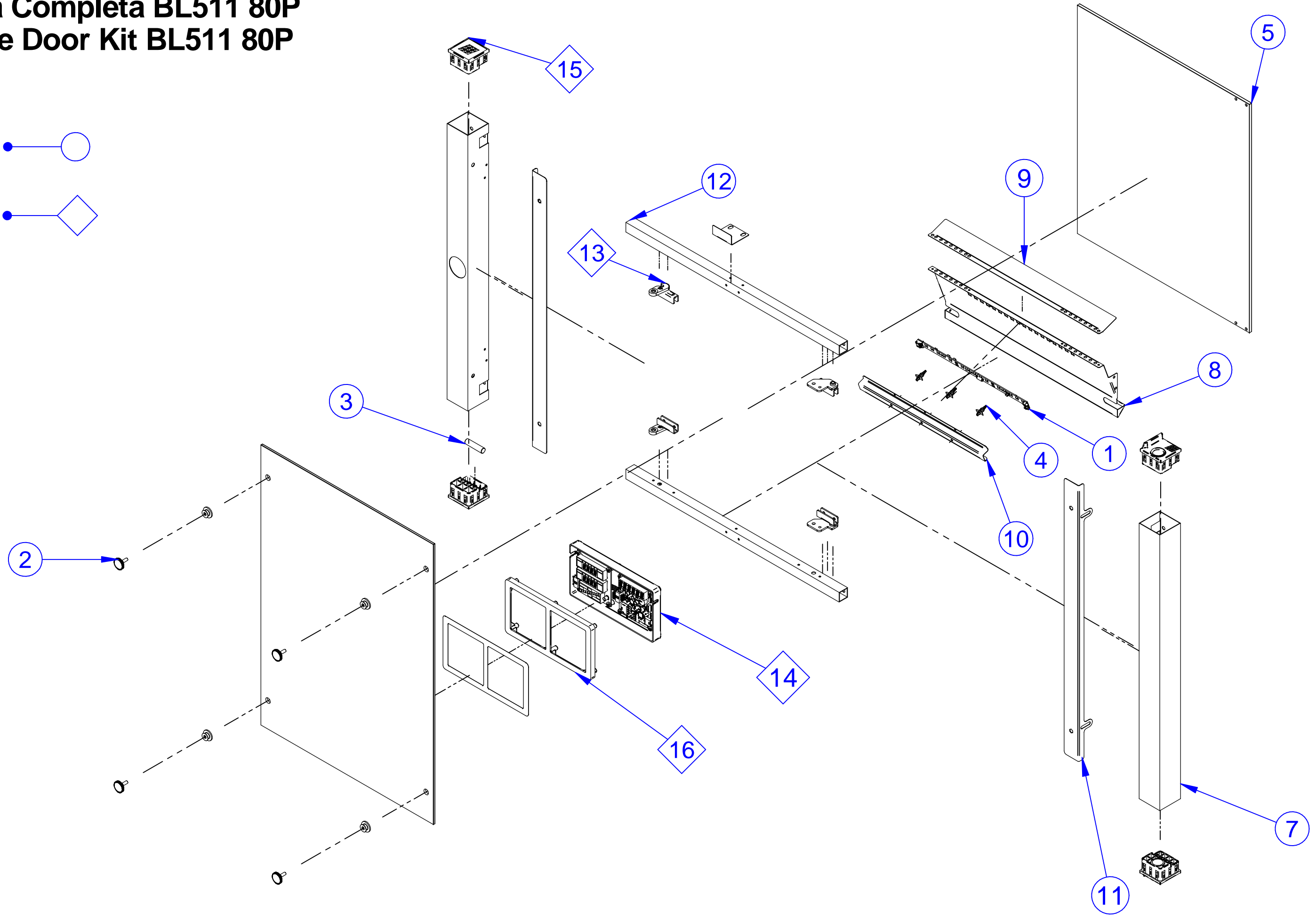
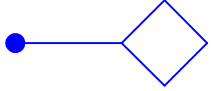

Kit Porta Completa BL511 Vision

Complete Kit BL511 Vision

Particolare
Single Item

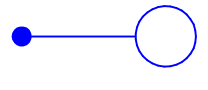

Kit

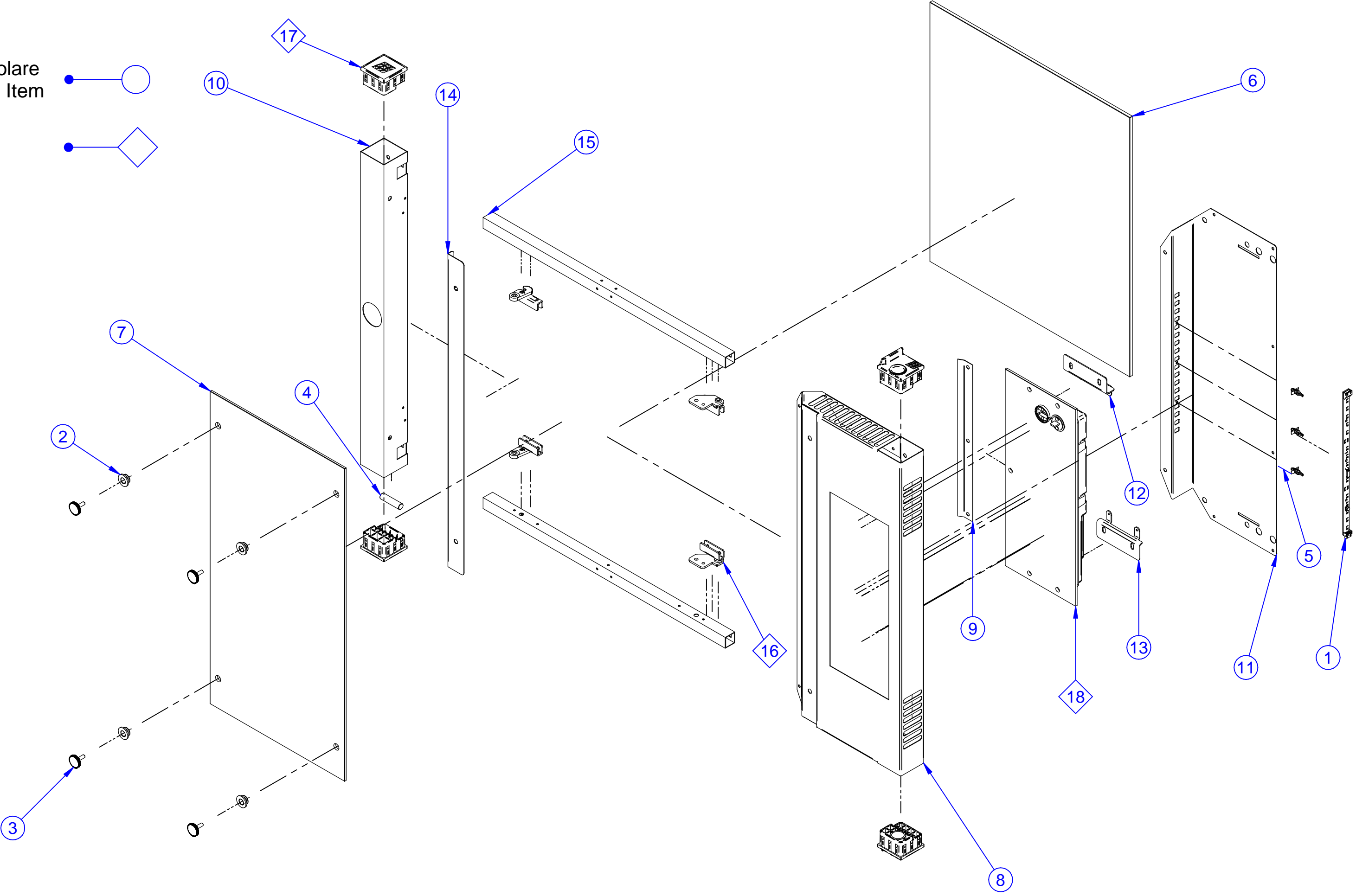
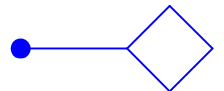

N.	Codice	Titolo	Description	Descripcìon	Descripcìon	Beschreibung	Q.
1		Kit Porta Completa BL511 Vision.asm	Complete Door Kit BL511 Vision.asm	Kit de puerta completo BL511 Vision.asm	Kit de porte complet BL511 Vision.asm	Kompletter Türensatz BL511 Vision.asm	1
2	113000015	Contattore Lovato 30-1NO 18A	Remote control switch Lovato 30-1NO 18A	Telerruptor Lovato 30-1NO 18A	Télerupteur Lovato 30-1NO 18A	Fernschalter Lovato 30-1NO 18A	2
3	120800020	Elettrovalvola 230V Mini JG8 Rid Rosso	Solenoid valve 230V Mini JG8 Rid Red	Electroválvula 230V Mini JG8 Rid Rojo	Electrovanne 230V Mini JG8 Rid Rouge	Magnetventil 230V Mini JG8 Rid Rot	1
4	123507020	Fascetta BloccaCavo PA268	Cable clamp PA268	Banda bloqueo cable PA268	Collier bloque-câble PA268	Kabelklemme PA268	1
5	153007020	Morsetto Terminale FV273 7 Poli	7-pole terminal clamp FV273 7	Terminal FV273 7 Polos	Borne terminal FV273 7 pôles	Klemme Terminal FV273 7-polig	1
6	153007050	Morsetto Equipotenziale a Pettine	Equipotential terminal comb	Terminal equipotencial peine	Borne équipotentielle peigne	Potentialausgleichsklemme Kamm	1
7	162300003	Passacavo a Membrana COD.IPC1005	membrane fairlead cod.ipc1005	pasacables de membrana cod.ipc1005	passe-câble avec membrane cod.ipc1005	membran-kabeldurchlass artikelnr.ipc1005	3
8	179600000	Sonda Jota Giunto Isolato 6x100 Cavo 1,5m	Insulated Jota joint probe 6x100 Cable 1.5m	Soda Jota junta aislada 6x100 cable 1,5m	Sonde Jota joint isolé 6x100 Câble 1,5m	Fühler Jota isolierte Verbindung 6x100 Kabel 1,5m	1
9	179607120	Sonda al Cuore Multipoint Bestfor	Heart probe Monopoint	Sonda corazón Monopoint	Coeur Monopoint sonde	Sonde Herzen Monopoint	1
10	182500035	TERMOSTATO DI SICUREZZA TU RM 335°C	Safety thermostat TU RM 335°C	Termostato de seguridad TU RM 335°C	Thermostat de sécurité TU RM 335°C	Sicherheitsthermostat TU RM 335°C	1
11	310507020	Cavo Collegamento Display-Potenza CB04V4000MKZZ	Display-Power connection cable CB04V4000MKZZ	Cablo conexión pantalla-potencia CB04V4000MKZZ	Câble de branchement écran-Puissance CB04V4000MKZZ	Anschlusskabel Display-Leistung CB04V4000MKZZ	1
12*	312000020	Clip Blocca Pinzetta 8 JG PMC1808R	8 JG Pliers Locking Clip PMC1808R	Clip bloqueo pinza 8 JG PMC1808R	Clip 8 JG PMC1808R	Klammer Pinzettenbefestigung 8 JG PMC1808R	9
13*	312000021	Clip Blocca Pinzetta 12 JG PIC1816R	12 JG Pliers Locking Clip PIC1816R	Clip bloqueo pinza 12 JG PIC1816R	Clip 12 JG PIC1816R	Klammer Pinzettenbefestigung 12 JG PIC1816R	1
14	313007020	Connettore Per Cavo D-P CNC PF04D1FF00	Connector for cable D-P CNC PF04D1FF00	Conector para cable D-P CNC PF04D1FF00	Connecteur pour câble D-P CNC PF04D1FF00	Steckverbinder für Kabel D-P CNC PF04D1FF00	1
15	313007023	Connettore Termocoppia K Miniatura	K thermocouple connector	Conector termopar k	Connecteur thermocouple K	Thermoelement-Stecker K	1
16	313207020	Coperchio Morsettiera	Terminal board cover	Tapa bornera	Couvercle bornier	Abdeckung Klemmenleiste	1
17	313207125	Coperchio Fori Cerniera	Hinge slot cover	Tapa orificios bisagra	Couvercle orifices charnière	Abdeckung Scharnierbohrungen	2
18	323502545	Fascetta Inox 25-45	Stainless steel clamp 78-98	Abrazadera Inox 78-98	Collier Inox 78-98	Schlauchselle Edelstahl 78-98	2
19	331300020	Gomito con codolo JG 8-8 PM220808E	Elbow with shank JG 8-8 PM220808E	Codo JG 8-8 PM220808E	Coude à cône JG 8-8 PM220808E	Bogen mit Schaft JG 8-8 PM220808E	1
20	331807020	Guarnizione Camera	Chamber gasket	Junta cámara	Joint chambre	Abdichtung Garraum	1
21	331807120	Guarnizione tubo ingresso acqua	Seal water inlet pipe	Sello del tubo entrada agua	Joint de tube entrée eau	Dichtung Zulaufschlauch	1
22*	337904443	Isolamento Camera	Room Isolation	Aislamiento de habitaciones	Isolation de la pièce	Raumisolierung	1
23	363600000	Passaparete Intermedio JG 8mm PM1208E	Intermediate coupling JG 8mm PM1208E	Pasa-pared intermedio JG 8mm PM1208E	Passe-mur intermédiaire JG 8mm PM1208E	Mittlerer Wanddurchlass JG 8mm PM1208E	1

N.	Codice	Titolo	Description	Descripcìon	Descripcìon	Beschreibung	Q.
24	366900008	Pres a Pannello 43R031121	Panel fitting 43R031121	Toma Panel 43R031121	Prise panneau 43R031121	Steckdose Panel 43R031121	1
25	366907020	Prolunga Connettore Seriale PH003_A01	USB logger interface	Interfaz USB Logger	Interface USB logger	USB-Schnittstelle Logger	1
26	373000000	Raccordo Porta Sonda Jota	Jota probe holder fitting	Rácor portasonda Jota	Raccordo porte sonde Jota	Anschluss Türfühler Jota	1
27	373000002	Raccordo a L D.8 1-4	L-shaped fitting D.8 1-4	Rácor en L D.8 1-4	Raccord en L D.8 1-4	L-förmiger Anschluss D.8 1-4	1
28	373000021	Raccordo intermedio Dritto 8-8 JG PM0408E	Straight intermediate fitting 8-8 JG PM0408E	Rácor intermedio recto 8-8 JG PM0408E	Raccord intermédiaire droit 8-8 JG PM0408E	Gerader Zwischenanschluss 8-8 JG PM0408E	1
29	373500050	Resistenza Bistrot 664 230V 5000W	Bistrot 664 heating element 230V 5000W	Resistencia Bistrot 664 230V 5000W	Résistance Bistrot 664 230V 5000W	Heizwiderstand Bistrot 664/364 230V 5000W	1
30	373500057	Resistenza Aggiuntiva 240V 1500W	Aux heating element 240V 1500W	Resistencia adicional 240V 1500W	Résistance supplémentaire 240V 1500W	Heizwiderstand zusätzlich 240V 1500W	2
31	374000020	Riduzione a Gomito JG 12/8 PM211208E	Elbow adaptor JG 12/8 PM211208E	Codo reductor JG 12/8 PM211208E	Raccord coudé de réduction JG 12/8 PM211208E	Bogenreduzierung JG 12/8 PM211208E	1
32	374100020	Riduttore di pressione 1.2 bar JG	Pressure reducer 1.2 bar JG	Reductor de presión 1.2 bar JG	Réducteur de pression 1.2 bar JG	Druckminderer 1.2 bar JG	1
33	378607025	Scheda Di Potenza PJ082_A02	Power board PJ082_A02	Tarjeta de potencia PJ082_A02	Carte de puissance PJ082_A02	Leistungskarte PJ082_A02	1
34	379200000	Segnalatore acustico nero	Black acoustic indicator	Avisador acústico negro	Avertisseur sonore noir	Summer schwarz	1
35	379206500	Sensore MK21-1A71C1000W	Sensor MK21-1A71C1000W	Sensor MK21-1A71C1000W	Capteur MK21-1A71C1000W	Fühler MK21-1A71C1000W	1
36*	381000003	Supporto Plastica MPDSDST2SIY00 8mm	Plastic support MPDSDST2SIY00 8mm	Soporte plástico MPDSDST2SIY00 8mm	Support en plastique MPDSDST2SIY00 8mm	Kunststoffhalterung MPDSDST2SIY00 8mm	9
37	385500002	Tubo in rame D. 8	Copper pipe D. 8	Tubo en cobre 8	Tuyau en cuivre D. 8	Kupferrohr D. 8	1
38	385500020	Tubo Pe Trasparente JG 8x6 PE-006-100M-N	Transparent PE Pipe JG 8x6 PE-006-100M-N	Tubo Pe trasparente JG 8x6 PE-006-100M-N	Tube Pe transparent JG 8x6 PE-006-100M-N	Transparenter PE-Schlauch JG 8x6 PE-006-100M-N	1
39	385500020	Tubo Pe Trasparente JG 8x6 PE-006-100M-N	Transparent PE Pipe JG 8x6 PE-006-100M-N	Tubo Pe trasparente JG 8x6 PE-006-100M-N	Tube Pe transparent JG 8x6 PE-006-100M-N	Transparenter PE-Schlauch JG 8x6 PE-006-100M-N	1
40	385500020	Tubo Pe Trasparente JG 8x6 PE-006-100M-N	Transparent PE Pipe JG 8x6 PE-006-100M-N	Tubo Pe trasparente JG 8x6 PE-006-100M-N	Tube Pe transparent JG 8x6 PE-006-100M-N	Transparenter PE-Schlauch JG 8x6 PE-006-100M-N	1
41	385500023	Tubo Gomma Radiatore d.30x38	Radiator Rubber Tube	Motor del sensor de rotor Mod PK020	Moteur de capteur de rotor Mod PK020	Gummischlauch-Heizkörper d.30x38	1
42	391500027	Ventola Ebm-Papst 4656N	Ebm-Papst 4656N fan	Ventilador Ebm-Papst 4656N	Vanne Ebm-Papst 4656N	Geblase Ebm-Papst 4656N	1
43	391500051	Ventola pala dritta 200x80 Airtech Mozzo Conico	200x80 Airtech Fan with tapered hub	Manga plana de ventilador 200x80 Airtech Hub cónico	Manchon d'avion de ventilateur 200x80 Hub conique d'Airtech	Lüfterhülse 200x80 Airtech Konische Nabe	1
44	500804820	Adattatore scarico 32/30mm	Discharge Adapter	Adaptador de descarga 32 / 30mm	Adaptateur de Refoulement	32 / 30mm Entladungsadapter	1
45	502604433	Alloggiamento sonda al cuore	housing core probe	Vivienda sonda aguja	Logement sonde à cœur	Kernfühlergehäuse	1
46	505604820	Basamento	Base	Base	Base	Unterteil	1

N.	Codice	Titolo	Description	Descripción	Descripción	Beschreibung	Q.
47*	510504820	Deflettore Sonda Temperatura					1
48	510604820	Camera Di Cottura	Cooking chamber	Cámara de cocción	Chambre de cuisson	Garraum	1
49	510604821	Carter Ventolina Raffreddamento	Carter Ventilation Cooling	Refrigeración por ventilación del cárter	Ventilation Carter Ventilation	Carter Lüftungskühlung	1
50	513104820	Convogliatore Aria	Air conveyor	Direccionador aire	Convoyeur d'air	Luftführung	1
51	546604820	Laterale Destro	Right side	Lateral derecho	Latéral droit	Rechte Seite	1
52	546604821	Laterale Sinistro	Left side	Lateral izquierdo	Latéral gauche	Linke Seite	1
53	563704820	Pannello Impianto Elettrico	Electrical system panel	Panel instalación eléctrica	Panneau installation électrique	Anlagentafel	1
54	563704821	Pannello Box Lavaggio	Washing Panel Panel	Panel del panel de lavado	Panneau de panneau de lavage	Waschepanel	1
55	566504820	Portateglie Sinistro Lamiera	Left hand Plate	Placa izquierda	Plaque gauche	Linke Platte	1
56	566504830	Portateglie Destro Lamiera	Right Sheet Metal Holder	Soporte derecho de chapa	Support de tôle droit	Rechter Blechhalter	1
57	573604820	Retro Forno	Oven Back	Trasera horno	Arrière four	Ofenrückseite	1
58	580306021	Squadretta Spruzzatori	Spray nozzle bracket	Escuadra rociadores	Équerre vaporisateurs	Winkelplatte Sprühdüsen	1
59	580306500	Squadretta spruzzatore	Spray nozzle bracket	Escuadra rociador	Équerre vaporisateur	Winkelplatte Sprühdüse	2
60	581007030	Supporto\Rinforzo Cerniera	Hinge support/reinforcement	Soporte/refuerzo bisagra	Support\Renforcement de la charnière	Scharnierhalterung\Verstärkung	4
61	581104820	Supporto Motori	Motor support	Soporte motores	Support moteurs	Motoren halterung	1
62	581104821	Supporto Elettrovalvola	Solenoid Support	Soporte del solenoide	Support de solénoïde	Magnethalterung	2
63	582604820	Tetto	Top panel	Techo	Toit	Abdeckung	1
64	585507120	Tubo Ingresso Aria	Air inlet pipe	Tubo entrada aire	Tuyau d'entrée de l'air	Luft Eintrittsrohr	1
65	585507121	Tubo Ingresso Acqua Corto	Water inlet pipe	Tubo entrada agua	Tuyau d'entrée de l'eau	Wassereinlaufrohr	1
66	591507120	Ventolina Vaporizzatore	Vaporizer fan	Fan vaporizador	fan vaporisateur	Fan verdampfer	1
67*	664107020	Perno supp. guida teglie 2 posizioni	Pan guide support pin - 2 positions	Perno sop. guía bandejas 2 posiciones	Axe supp. glissière plats à four 2 positions	Zapfen Blechführungshalter 2 Stellungen	8
68	711007030	Kit Cerniere Porta Serie Star	Door hinge Serie Star Kit	Kit Bisagra puerta Serie Star	Kit charnière porte Serie Star	Türscharnier Kit Serie Star	1
69	715807120	Kit Contagiri MFA80	Rev counter kit MFA80	Tacómetro kit MFA80	Tachymètre kit MFA80	Kit drehzahlmesser MFA80	1

<i>N.</i>	<i>Codice</i>	<i>Titolo</i>	<i>Description</i>	<i>Descripcìon</i>	<i>Descriptiòn</i>	<i>Beschreibung</i>	<i>Q.</i>
70	751607900	Kit Maniglia Serie Star	Handle Serie Star Kit	Kit Tirador Serie Star	Kit Poignée Serie Star	Griff Kit Serie Star	1
71	753000121	Kit Motore Mod_MFA80H25-VA 230V-ALBconico	Mod_MFA80H25-VA 230V-ALBconico Engine Kit	Kit de motor Mod_MFA80H25-VA 230V-ALBconico	Kit moteur Mod_MFA80H25-VA 230V-ALBconico	Mod_MFA80H25-VA 230V-ALBconico Motor Kit	1
72*	753104820	Kit Porta Completa BL511 80P	Complete Door Kit BL511 80P	Kit de puerta completo BL511 80P	Kit de porte complet BL511 80P	Komplettes Türensset BL511 80P	1
73	764507020	Kit 4 Piedini di Supporto Forno	Oven 4 feet kit	Kit 4 Patas soporte	Kit 4Pieds de support	Kit 2 Ofenstützfüße	1
74	779207030	Kit Serrature in Plastica	Plastic lock Kit	Kit Cerradura de plástico	Kit Serrure en plastique	Schlösserkit aus Kunststoff	1
75	779604620	Kit Sonda Multipoint e installazione	Multipoint probe kit and installation	Kit de sonda multipunto e instalación	Kit de sonde multipoint et installation	Multipoint Probe Kit und Installation	1
76	779607120	Kit Sistema Attuatore	Actuator System Kit	Kit sistema Actuador	Kit Système Actionneur	Kit Antrieb System	1
77*	Codice	Fascetta Plastica	Plastic clamp	Banda de plástico	Collier plastique	Kunststoff-Schlauchschelle	4
78	Commerciale	Condensatore 5mF Ducati Energia	Condenser 5mF Ducati Energia	Condensador 5mF Ducati Energia	Condensateur 5mF Ducati Énergie	Kondensator 5mF Ducati Energie	1

Kit Porta Completa BL511 80P

Complete Door Kit BL511 80P

N.	Codice	Titolo	Description	Descripción	Description	Beschreibung	Q.
1	305507050	Scheda Barra LED N034_2	Electronic board led bar	Tarjeta led bar	Electronic board LED bar	Karte led bar	1
2	351600007	Manopola Zigrinata M5	Knurled knob M5	Mando estriado M5	Manette crénelée M5	Rändeldrehknopf M5	4
3	351600008	Magnete Micro Porta	Door micro magnet	Imán microinterruptor puerta	Micro Interrupteur Porte	Türmikromagnet	1
4	381000004	Supporto plastica MPDSDST5SIY00/6 mm	Plastic support MPDSDST5SIY00/6 mm	Soporte plástico MPDSDST5SIY00/6 mm	Support en plastique MPDSDST5SIY00/6 mm	Kunststoffhalterung MPDSDST5SIY00/6 mm	3
5	391604821	Vetro Interno	Internal glass	Vidrio interno	Vitre interne	Innenglas	1
6*	553104820	Montante Porta Lato Maniglia Plastica	Door upright on plastic handle side	Montante puerta lado tirador plástico	Montant porte côté poignée en plastique	Türholm Kunststoffgriffseite	1
7	553104821	Montante Porta Lato Cerniere	Door upright on hinge side	Montante puerta lado bisagras	Montant porte côté charnière	Türholm scharnierseitig	1
8	578704820	Schermo Protezione Centralina	Control unit protection screen	Pantalla protección centralita	Écran de protection de la centrale	Schutzabdeckung Steuereinheit	1
9	578704822	Schermo Led 80 Programmi	LED Shield	Proteccion LED	Protecion de LED	LED Schutz	1
10	581004820	Supporto Barra LED	LED Bar Support	Soporte de barra LED	Support de barre de LED	LED Bar Unterstützung	1
11	581204820	Supporto Vetro Esterno	External glass support	Soporte cristal externo	Support vitre externe	Außenglashalterung	2
12	584504820	Traversa Porta	Door cross-piece	Travesaño puerta	Barre porte	Querstrebe der Tür	2
13	712007122	Kit Montaggio Vetro Interno Serie Slim	Assembly inner Glass Serie Star_2 Kit	Kit Montaje vidrio interno Serie Star_2	Kit Assemblée vitre interne Serie Star_2	Montage Kit inner Glases Serie Star_2	1
14	715707021	Kit Centralina Frontale Serie Star Orizzontale	Front Control unit Serie Star Kit (horizontal)	Kit Frontal centralita Serie Star (horizontal)	Kit Frontal centrale Serie Star (horizontale)	Vorderseitiges Steuerneinheit-Kit Serie Star (waagerecht)	1
15	782007020	Kit Tappi Porta Serie Star	Door plugs Serie Star Kit	Kit Tapón puerta Serie Star	Kit Cache porte Serie Star	Türabdeckkappe Kit Serie Star	1
16	791604820	Kit Vetro Ext 5T Slim 80P.asm	Glass kit Ext 5T Slim 80P.asm	Kit de vidrio Ext 5T Slim 80P.asm	Kit de vitrage Ext 5T Slim 80P.asm	Glas-Kit Ext 5T Slim 80P.asm	1

Kit Porta Completa BL511 Vision

Complete Kit BL511 Vision

N.	Codice	Titolo	Description	Descripcìon	Descriptiòn	Beschreibung	Q.
1	305507050	Scheda Barra LED N034_2	Electronic board led bar	Tarjeta led bar	Electronic board LED bar	Karte led bar	1
2	308200011	Boccola Fissaggio Vetro Foro 11mm	Bore Hole Fixing Bush	Agujero de montaje de Bush 11mm	Trou de fixation du trou d'alésage	Buchsen-Befestigungsloch 11mm	4
3	351600007	Manopola Zigrinata M5	Knurled knob M5	Mando estriado M5	Manette crénelée M5	Rändeldrehknopf M5	4
4	351600008	Magnete Micro Porta	Door micro magnet	Imán microinterruptor puerta	Micro Interrupteur Porte	Türmikromagnet	1
5	381000004	Supporto plastica MPDSDST5SIY00/6 mm	Plastic support MPDSDST5SIY00/6 mm	Soporte plástico MPDSDST5SIY00/6 mm	Support en plastique MPDSDST5SIY00/6 mm	Kunststoffhalterung MPDSDST5SIY00/6 mm	3
6	391604821	Vetro Interno	Internal glass	Vidrio interno	Vitre interne	Innenglas	1
7	391604825	Vetro Esterno Centralina Vision	Exterior Glass Vision Control Unit	Unidad de control de visión exterior de vidrio	Unité de contrôle de vision vitrée extérieure	Außenglas Vision Control Unit	1
8	513304820	Cruscotto Centralina Vision	Dashboard Vision control unit	Unidad de control de la vista del tablero	Unité de commande Dashboard Vision	Dashboard Vision-Steuergerät	1
9	524507120	Fissaggio Vetro Cruscotto Centralina	Fixing Glass Dashboard Control Unit	Reparación de la unidad de control del tablero de vidrio	Unité de commande de tableau de bord en verre	Befestigung der Glass Dashboard Control Unit	1
10	553104820	Montante Porta Lato Maniglia Plastica	Door upright on plastic handle side	Montante puerta lado tirador plástico	Montant porte côté poignée en plastique	Türholm Kunststoffgriffseite	1
11	578704821	Schermo Protezione Centralina Vision	Vision Control Protection Screen	Pantalla de Protección de Control de Visión	Écran de protection de contrôle de vision	Vision Control Schutz Bildschirm	1
12	581004510	Supporto Superiore Centralina Vision	Higher support unit Vision	Apoyo superior Unidad Visión	Soutenir supérieur de l'unité Vision	Unterstützen Höhere Einheit Vision	1
13	581004511	Supporto Inferiore Centralina Vision	Lower support unit Vision	Apoyo inferior Unidad Visión	Support inférieur de l'unité Vision	Unterstützen unteren Einheit Vision	1
14	581204820	Supporto Vetro Esterno	External glass support	Soporte cristal externo	Support vitre externe	Außenglashalterung	1
15	584504820	Traversa Porta	Door cross-piece	Travesaño puerta	Barre porte	Querstrebe der Tür	2
16	712007122	Kit Montaggio Vetro Interno Serie Slim	Assembly inner Glass Serie Star_2 Kit	Kit Montaje vidrio interno Serie Star_2	Kit Assemblée vitre interne Serie Star_2	Montage Kit inner Glases Serie Star_2	1
17	782007020	Kit Tappi Porta Serie Star	Door plugs Serie Star Kit	Kit Tapón puerta Serie Star	Kit Cache porte Serie Star	Türabdeckkappe Kit Serie Star	1
18	791604513	Kit Vetro Centralina Vision S2X	Removable Vision Control Unit S2X Kit	Kit Desmontable centralita Vision S2X	Kit amovible centrale Vision S2X	Abnehmbarem ecu Vision S2X Kit	1