

GASTRONOMY OVEN - BAKERY OVEN
MECHANICAL CONTROL



Manual of use and installation

1. SAFETY WARNINGS	4
1.1 SAFETY STANDARDS FOR THE USER.....	4
1.2 SAFETY STANDARDS FOR THE INSTALLER.....	5
1.3 EXPLANATION OF PICTOGRAMS.....	6
1.4 SAFETY STANDARDS FOR COOKING AND WASHING.....	6
1.5 HOW TO READ LABEL TECHNICAL SPECIFICATIONS	7
2. TRANSPORT.....	7
2.1 TRANSPORT EQUIPMENT.....	7
2.2 CHARACTERISTICS OF THE POSITIONING ROOM	7
2.3 INSTALLING EQUIPMENT	7
3. POSITIONING	8
3.1 STANDING ON TOP OF A TABLE/CLOSET	8
3.2 STANDING ON A PROOFER	9
3.3 STANDING ON A OVEN	9
3.4 STANDING ON A STAND	9
4. ELECTRICAL CONNECTIONS	9
4.1 HOW TO MAKE THE CONNECTION.....	10
4.2 REPLACEMENT OF THE POWER CABLE.....	11
5. WATER CONNECTIONS	11
5.1 INCOMING WATER.....	11
5.2 INLET WATER CHARACTERISTICS.....	11
5.3 OUTGOING WATER	12
6. EXHAUST FUMES.....	12
7. BASIC NOTIONS FOR THE FIRST IGNITION	12
7.1 FILM REMOVAL.....	13
7.2 TYPES OF COOKING	13
7.3 MANUAL COOKING	14
8. MECHANICAL CONTROL PANELS.....	15
9. CLEANING AND MAINTENANCE	16
9.1 GENERAL CLEANING WARNINGS.....	16
9.2 CLEANING OF THE DOOR AND INTERNAL GLASS	17
9.3 ROUTINE AND MANUAL CLEANING OF THE COOKING CHAMBER.....	17
9.4 CLEANING OF EXTERNAL SURFACES	18
9.5 REPLACEMENT OF THE BULB	18
9.6 MAINTENANCE IN CASE OF BREAKAGE	18
10. PERIODS OF INACTIVITY	20
11. END-OF-LIFE DISPOSAL.....	20
11.1 EQUIPMENT DISPOSAL.....	20
11.2 INFORMATION ON DISPOSAL IN THE EUROPEAN UNION	20

1. SAFETY WARNINGS



Failure to comply with the following guide can cause even fatal damages and injuries, causes the warranty to expire and relieves the Builder of any liability. Read this booklet carefully before installation, use and maintenance of the equipment and keep it carefully for any further future consultation by the various operators. If you have not understood all the contents of this booklet, please contact the Builder. In the event of loss or deterioration of the documentation, please request the Manufacturer to send the replacement one.

1.1 SAFETY STANDARDS FOR THE USER

- Before the ordinary use and maintenance of the equipment read this booklet carefully and keep it carefully for any further future consultation by the various operators. If some parts are not understandable, contact the Builder.
- In case of transfer of the equipment to the new user this booklet.
- A use, cleaning and maintenance other than those indicated in this book are considered improper and can cause damage, injury or fatal accidents, cause the warranty to expire and relieve the Builder of any liability.
- Cleaning and maintenance intended for the user shall not be carried out by children without supervision.
- Children must be supervised to ensure that they do not play with the appliance.
- This appliance shall only be used for cooking food in professional kitchens by qualified personnel: any other use is not in accordance with the intended and therefore dangerous use.
- It is recommended to monitor the equipment throughout its operation.
- The apparatus may be used by children under the age of 8 years and by persons with reduced physical, sensory or mental capacity, or inexperienced or from the necessary knowledge, provided that they have been supervised or after they have received instructions on the safe use of the apparatus and on the understanding of the dangers inherent therein. Children don't have to play with braces. Cleaning and maintenance intended to be carried out by the user and shall not be carried out by children without supervision.
- If the equipment does not work or you notice functional or structural anomalies, disconnect it from the power supply and water and contact a Service Center authorised by the Builder without attempting to repair it itself. For a possible repair request the use of original spare parts. Failure to comply with this requirement causes the Warranty to lapse.
- In order to ensure that the appliance is in perfect conditions of use and safety, it is recommended that it be subjected to maintenance and control by an authorised service centre at least once a year.
- Do not obstruct any air intake on the equipment. The user shall carry out only ordinary cleaning operations. For inspection, extraordinary maintenance and replacements of defective components, please contact an Authorised Service Centre for the sending of a skilled and properly trained technician.





- Before any cleaning, it is necessary to disconnect the power supply of the appliance and wear appropriate personal protective equipment (e.g. gloves, etc.).
- If the appliance is fitted with wheels or is placed on top of a cabinet with wheels, its freedom of movement must be limited by anti-movement devices (e.g. chains) so that during movement it cannot in any way damage electrical cables and water and drainage pipes.

1.2 SAFETY STANDARDS FOR THE INSTALLER

- All extraordinary installation and maintenance operations must be carried out only by qualified personnel authorised by the Manufacturer, in accordance with the rules in force in the country of use and complying with the rules relating to plant and safety at work.
- Before installing the equipment, verify the conformity of the systems with the regulations in force in the country of use and to what is reported on the technical data plate.
- The equipment shall be disconnected from the power supply before any installation or maintenance work is carried out.
- Interventions, tampering or modifications not expressly authorised and which do not comply with the provisions of this manual will terminate the warranty. An installation or maintenance other than those indicated in this booklet may cause injury or fatal accidents to the installer and the user and cause damage to the facilities of the place of installation.
- During the installation of the equipment, the transit or permanence of persons not engaged in installation near the work area shall be prohibited.
- Replacement of the power cable shall be carried out only by a qualified and authorised technician. The cable may only be replaced with one of similar characteristics: the technical data plate always indicates the type of cable to be used and its section. The grounding cable must always be green yellow.
- The technical data plate shall provide important technical information which is indispensable in the event of an application for maintenance or repair of the equipment: it is therefore recommended not to remove, damage or modify it.
- Packaging material, as potentially dangerous, must be kept out of the reach of children or animals and properly disposed of in accordance with local standards.

1.3 EXPLANATION OF PICTOGRAMS

Installation and use instructions shall apply to all models unless otherwise specified in the following pictograms:

	<ul style="list-style-type: none">• It's a danger! Immediate danger or dangerous situation that could cause injury or death.
	<ul style="list-style-type: none">• Read the instruction manual
	<ul style="list-style-type: none">• Grounding symbol
	<ul style="list-style-type: none">• Symbol of equipotential

1.4 SAFETY STANDARDS FOR COOKING AND WASHING

- Before use ensure that no non-compliant objects (instruction booklets, plastic bags or anything else) or residues of detergents are present in the chamber of the equipment; likewise, make sure that the smoke discharge is free of obstruction and there are no flammable materials in its vicinity.
- To move containers, accessories and other objects inside the cooking chamber, always wear protective thermal clothing (DPI) suitable for use (e.g. thermal gloves).
- During cooking and until cooling, the external and internal parts of the equipment could be very hot (temperature greater than 60 °C/140 °F). To avoid the danger of burns, it is recommended not to touch the areas marked with this symbol.
- Take the utmost care when extracting the baking trays from the equipment chamber, especially if they contain liquids. Do not use easily flammable foods or liquids during cooking (e.g. alcohol). Make sure that the baking tray structures inside the cooking room are well locked on the walls. Otherwise, baking trays containing food or hot liquids may fall, causing risk of burns.
- Always keep the cooking room clean, making a daily cleaning: fats or food residues if not removed from the inside could set fire!
- Do not place heat sources (e.g. grids, deep fryers, etc.), highly flammable or combustible substances near the appliance (e.g. diesel, petrol, alcohol bottles, etc.).

1.5 HOW TO READ LABEL TECHNICAL SPECIFICATIONS

- A) Article
- B) Model
- C) Reference
- D) Serial number
- E) Operating pressure
- F) Degree of protection
- G) Electrical data
- H) Weight of equipment

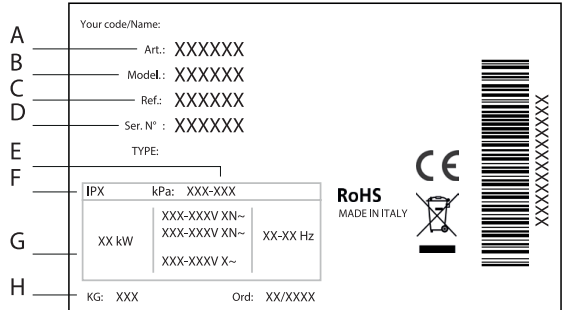

2. TRANSPORT

2.1 TRANSPORT EQUIPMENT

By wearing personal protective equipment, bring the equipment to the installation space using a fork trolley: the correct transport must be done by threading the forks from the front side, taking care not to damage the lanes of the trolley and the exhaust pipe that are located at the bottom of the furnace.

The equipment should never be overturned, dragged or overturned! During handling, the transit or stay of non-employed persons near the work area shall be prohibited.

2.2 CHARACTERISTICS OF THE POSITIONING ROOM

The positioning room shall:

- Be well aerated and not exposed to atmospheric agents;
- Have a temperature between + 5 °C and + 45 °C (+ 41 °F and + 113 °F) and humidity below 70 %;
- Have a flooring free of roughness, perfectly leveled and supporting the equipment at full load;
- To comply with current regulations in terms of safety at work and plant;
- Be dedicated to the preparation of food;

2.3 INSTALLING EQUIPMENT

The equipment shall be installed:

- Under a suction hood of adequate power (it is advisable to install the hoods of the manufacturer for optimal performance);
- In such a way as to have access to water and electrical connections;
- Away from flammable and/or potentially explosive materials (e.g. gas cylinders);
- Taking into account that the door of the equipment can be opened completely.

It is not recommended to place close to other equipment that reaches high temperatures. In case there is a need to provide a space of at least 50 cm lateral and 70 cm back from them or interpose an insulating wall.

For safety reasons, do not place the highest baking tray at a height of more than 160 cm.

If this is necessary, the “danger burns” adhesive supplied to the equipment at the specified height must be applied.

Do not place the equipment in the vicinity of flammable materials or containers (e.g. partition walls, gas cylinders, etc.) due to fire hazard. Cover any walls with non-flammable thermal material.

The equipment is not suitable for collection.

When choosing the positioning room, take into account that the equipment must be easily moved for any extraordinary maintenance: be careful that any subsequent masonry works (e.g. construction of walls, replacement of doors with narrower ones, renovations, etc.) do not hinder movement.

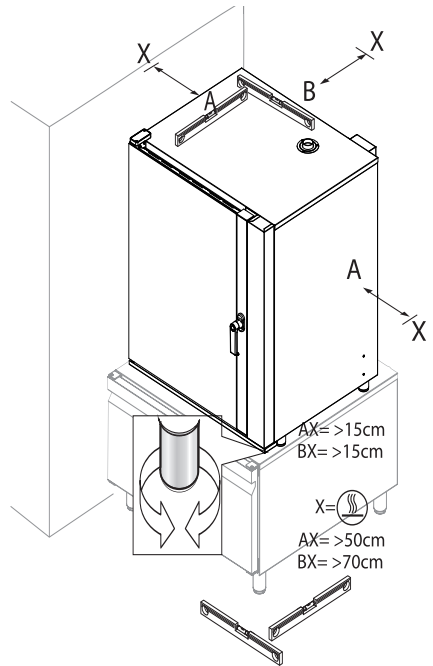

3. POSITIONING

The equipment can be positioned:

- above a table or closet of the user;
- above a compatible lever;
- above a compatible oven;
- above a compatible blast chiller;
- above a structure of the Builder (stand).

Direct ground support of the equipment is not permitted. They are available from the Builder and/or Dealer of the supports to be placed under it to obtain the desired height from the ground.

Do not install equipment without feet.

The maximum number of overlapping equipment is two.

3.1 STANDING ON TOP OF A TABLE/CLOSET

If the equipment is positioned above a work table or a neutral cabinet, the latter must be perfectly level and stable, it must support the equipment at full load and the support surface must be flame-retardant and possibly resistant to high temperatures. Possibly act on the feet of the equipment to adjust the bubble.

3.2 STANDING ON A PROOFER

If the equipment is placed above a proofer of the same series, it is sufficient to place it on top of it, ensuring that the feet are stable and fit into the pins of the lower structure.

3.3 STANDING ON A OVEN

If the equipment is positioned above ovens of the same series it is mandatory to mount the overlay kit to be requested from the Builder, then insert the base of the furnace feet into the pins of the lower equipment. For the assembly instructions of the superposition kit, please refer to the sheet in the packaging of the superimposed kit..

3.4 STANDING ON A STAND

If the equipment is positioned above a stand, insert the base of its feet into the pins of the lower structure.

It is always possible to complete your composition, adding or replacing complementary accessories and equipment, in this way it is possible to satisfy every need of cooking or space. Visit our website or contact us for any information about it

DOOR ADJUSTMENT

If the door struggles to close, it is possible to act on the hake by rotating it with a clamp to obtain a perfectly horizontal position.

4. ELECTRICAL CONNECTIONS

BE CAREFUL!

Before proceeding to the electrical connection, read carefully the safety warnings on the first pages of this manual and always compare the system data with those shown in the technical data plate.

The connection to the power supply network must comply with the regulations in force in the country of installation of the equipment and must be performed by qualified personnel authorised by the Builder. Failure to comply with these norms can cause damage and injury, causes the warranty to lapse and relieves the Builder of any liability.

When the appliance is in operation, the power supply voltage value shall not differ by ± 10 % of the value shown on the technical data plate.

The illustrated connection and the colours of the cables are indicative, please refer only to the diagram shown on the equipment.

The equipment must be connected directly to the electricity grid and must be provided with an easy-to-access switch upstream and installed to the plant in accordance with the regulations in force in the country of installation of the equipment. This switch shall have an omnipolar contact separation so as to ensure complete disconnection under the overvoltage category III.

A proper ground connection

is required and the ground cable must not be interrupted under any circumstances by the protection switch.

When several appliances are present in the same environment, it is mandatory to provide an equipotential connection using the appropriate clamp marked by the symbol in the lower back of the appliance.

This clamp allows to connect a ground cable according to applicable legal requirements. The effectiveness of the equipotential system should be properly checked in accordance with the legislation in force.

There is a sticker on the equipment that indicates how to connect to the terminal block according to the type of voltage available.

To make connections use only the bridges provided.

4.1 HOW TO MAKE THE CONNECTION

- Open the back of the equipment and locate the terminal block.
- Loosen the cable entry and insert the power cord through it. The adhesive applied to the sideboard always indicates the type of cable to be used and its section, depending on the voltage and absorption of the equipment
- (eg.) Cable: Cable: 5x10 mm² H07RNF).
- Connect the cable conductors following the diagram on the external adhesive plate: make **ONLY** the links indicated without changing them. The yellow/green earth conductor shall be at least 3 cm longer than the other conductors.
- PE (yellow/green): earth protection conductor
- N (blue): neutral conductor
- L1/2/3 (brown/grey/black): phase conductors
- An incorrect connection could cause overheating to the terminal block leading to melting and the risk of electric shocks.
- Check the absence of electrical dispersion between phases and earth. Check the electrical continuity between the external carcass and the ground wire of the grid. It is recommended to use a multimeter to perform these operations.
- Close the side with the screws and lock the cable by screwing the nut of the cable presser.

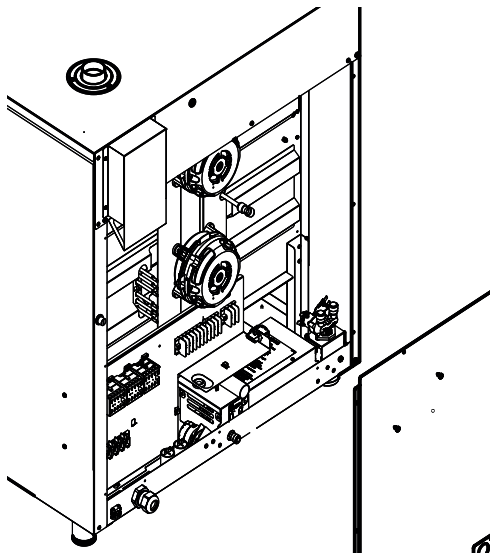

4.2 REPLACEMENT OF THE POWER CABLE

This operation shall only be carried out by a qualified and authorised technician. The cable may only be replaced with one of similar characteristics: the technical data plate always indicates the type of cable to be used and its section. The grounding cable must always be green yellow.

5. WATER CONNECTIONS

5.1 INCOMING WATER

The equipment is equipped with an input Ø 12 mm. It is also supplied a 1.5 m tube complete with a filter and a JG 3/4 connection as required by current regulations, to be mounted during installation.

For connection use only the material provided, do not use or reuse other pipes.

Before connecting the pipe to the appliance, let water drain to eliminate any impurities present in the water pipeline.

Provide a gate valve for closing the water supply as needed.

5.2 INLET WATER CHARACTERISTICS

The incoming water must have the following characteristics:

- maximum temperature of 30 °C (86 °F);
- maximum hardness of 5 °f (French degrees) to avoid accumulation of limestone inside the cooking chamber;
- be drinkable;
- pressure values between 150 kPa (1.5 bar) and 200 kPa (2 bar).

Pressure below 150 kPa (1.5 bar): the equipment could work incorrectly.

Pressure greater than 200 kPa (2 bar): install a pressure reducer calibrated to 200 kPa (2 bar).

Water hardness indicates the content of magnesium, calcium and heavy metals present in the water.

It is measured using kits that are easily available on the market.

The hardness is expressed in French (°f) or German (dH) degrees (1 °dH German degrees = 1.8 °f French degrees – 1 °f = 10 mg calcium carbonate (CaCO₃) per litre of water).

Water classification:

- very sweet up to 7 °f
- desserts from 7 °f to 14 °f
- average hard from 14 °f to 22 °f
- discretely hard from 22 °f to 32 °f
- hard from 32 °f to 54 °f
- very hard over 54 °f

In the case of excessively hard water (> 5 °F) use demineralisers (available from the Manufacturer/Retailer); excessive hardness of water could cause accumulation of limestone inside the cooking chamber and damage the internal pipes, heating elements, fans, solenoid valves.

5.3 OUTGOING WATER

Connect the exhaust to a non-metallic flexible hose in a degree of withstanding high temperatures (over 90 °C).

The discharge shall have the following characteristics:

- be siphoned (siphon not supplied);
- be up to one meter long;
- have a minimum gradient of 4 %;
- do not have bottlenecks;
- have an air gap of at least 25 mm;
- have a diameter not less than that of the exhaust coupling.

6. EXHAUST FUMES

During cooking hot fumes and odors are produced evacuated from the exhaust fireplace that is located at the top of the equipment.

The latter must be placed under an extractor hood of flow rate and size appropriate to the type of equipment.

The Builder recommends the installation of his hoods; for their assembly please refer to the instructions contained in the packaging of the hoods.

The hood shall remain on during all operation of the equipment. Make sure that no objects and/or materials are present above the fume discharge that can obstruct the outflow of the fumes or be damaged by the temperature or the fumes themselves.

Do not leave flammable materials near the exhaust pipe.

7. BASIC NOTIONS FOR THE FIRST IGNITION

The use of its equipment is simple and intuitive. In the following pages we will guide you step by step in the knowledge of the equipment: this will give you the certainty of obtaining results that always meet your expectations and will guarantee optimal performance and long life of your equipment.

7.1 FILM REMOVAL

Remove the protective film from the furnaces avoiding the use of abrasive/aggressive substances or metal objects (e.g. scrapers).

If glue residues remain, rub with a soft cloth soaked in oil-based detergent, suitable for surfaces in stainless steel, non-aggressive or abrasive. Avoid the use of scrapers, abrasive or sharp tools.

- At first use of the equipment, clean the inside of the room thoroughly by washing. Make sure that the equipment chamber and chimneys/flowers are free of non-compliant objects (booklets, plastic bags, etc.).
- Avoid salting the food in the cooking chamber. If not avoidable, clean the equipment as soon as possible.
- Avoid overloading the food or overloading the baking trays (maximum 10 kg per baking tray).
- Spread the baking trays evenly over the entire height of the cooking chamber, respecting the maximum number indicated for each appliance. Always respect the load instructions of the equipment in your possession
- In the case of cooking with grills of particularly fat foods (e.g. roasts or poultry), place a baking tray with high edges at the bottom of the cooking chamber for the collection of fats that drain from foods.
- For optimal results, open the door as little as possible during cooking.
- Use the equipment with an ambient temperature between + 5 °C and + 45 °C (+ 41 °F and + 113 °F).

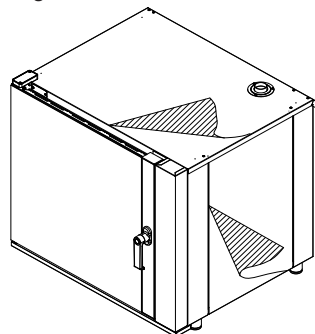

7.2 TYPES OF COOKING

ATTENTION: For a good cooking it is necessary to preheat the oven before each cooking. It is advisable to pre-heat with a temperature set at least 30°C higher than the cooking temperature.

Increase the temperature in case of full load.

• CONVECTION COOKING

Food cooks thanks to the dry heat generated by the heating elements. Fans allow a uniform diffusion of hot air in the cooking chamber.

In case of need, this type of cooking allows to manually introduce humidity into the chamber.

- **STEAMING COOKING**

The food is cooked by steaming in the room. To ensure optimal results it is necessary that the humidity value is set to “100 %”. For the humidification function to function satisfactorily, the temperature must be set at at least 80-100 °C. Steaming is ideal for all those dishes that require “delicate” cooking or for pasteurisation of creams.

- **COMBI COOKING**

The food cooks thanks to the high temperature generated by the resistances associated with the steam automatically injected into the chamber.

7.3 MANUAL COOKING

The operator has the option to set:

- Temperature in the chamber;
- Humidity adjustment;
- Fan speed (in the models in which it is available).
- If the cooking time has been set in time (ex.30: minutes) it will end at the end of the cooking time (0.00).

8. .MECHANICAL CONTROL PANELS

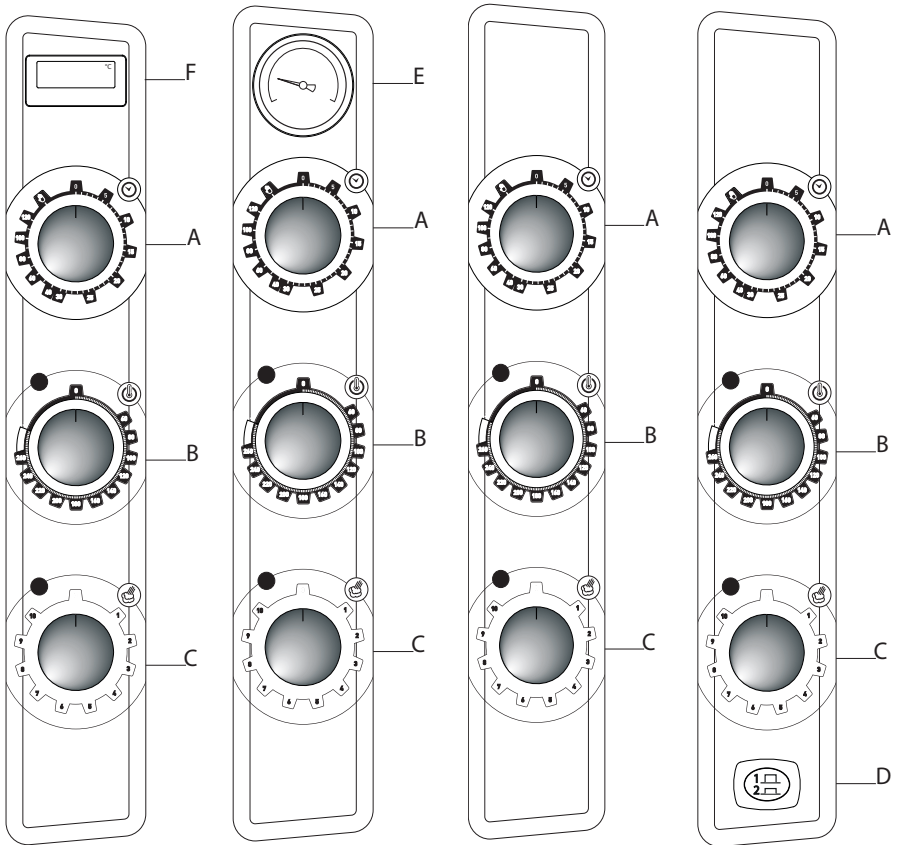

A	Time adjustment knob
B	Temperature adjustment knob
C	Knob steam regulation\ humidification
D	Ventilation adjustment button
E	Temperature indicator
F	Display temperature display

- **TIME ADJUSTMENT**

When the manual option is selected, the oven will always be switched on for an infinite time until the operator intervenes. When a certain value is selected, the oven remains on for that amount of time (maximum 120 minutes).

- **TEMPERATURE ADJUSTMENT**

This knob allows you to select the desired cooking temperature.

- **THERMOSTAT SPY**

This indicator lamp is turned on when the heating elements of the oven are switched on and therefore the internal temperature of the cooking chamber is lower than the value set by the thermostat knob. When the light is switched off means that the heating is off and that the cooking chamber has reached the set temperature.

- **STEAM/HUMIDITY ADJUSTMENT**

This knob allows you to activate the humidification function. It is adjustable from minimum to maximum by turning the knob clockwise.

ATTENTION: For the humidification function to work satisfactorily, the temperature must be set to at least 80-100 °C. In addition, for good cooking it is necessary to preheat the oven to the desired temperature before activating the steam supply.

- **HUMIDIFICATION LED**

When it is turned on means that you are putting water into the cooking room to get steam. This is done independently of the temperature (it is up to the operator to check that the temperature is sufficiently high for the cooking to proceed properly).

- **SPEED ADJUSTMENT**

The furnace has two different fan/engine speeds:

- 1-Max: it means that the engine is at maximum speed and is used in most cooking.
- 2-Min: it means that the engine is at minimum speed and is mainly used for delicate dishes, such as pastry

9. CLEANING AND MAINTENANCE

9.1 GENERAL CLEANING WARNINGS

- Before doing any cleaning, it is necessary to disconnect the power supply of the appliance and wear appropriate personal protective equipment (e.g. gloves, etc.)The user must carry out only ordinary cleaning operations. For inspection, extraordinary maintenance and replacements of defective components, please contact an Authorised Service Centre for the sending of a skilled and properly trained technician.

- The Manufacturer does not recognise as a guarantee any damage resulting from a failure to maintain or from incorrect cleaning (e.g. the use of unsuitable detergents).
- Before any cleaning, wait for the cooking chamber to be cold (temperature not exceeding 70 °C).

For cleaning any part of the equipment or accessory, do NOT use:

- Abrasive or powdered detergents;
- Aggressive or corrosive detergents (e.g. hydrochloric/muriatic or sulfuric acid, caustic soda, etc.). Be careful! Do not even use these substances to clean the substructure/floor under the equipment;
- Abrasive or sharp tools (e.g. abrasive sponges, scrapers, steel brushes, etc.);
- Steam or pressure water jets.

9.2 CLEANING OF THE DOOR AND INTERNAL GLASS

To clean the glass inside the door wait until the oven has completely cooled. The inner crystal can be opened for easy cleaning.

Use a freshly moistened soft cloth of a neutral product, specifically for crystals, following the instructions of the detergent manufacturer.

9.3 ROUTINE AND MANUAL CLEANING OF THE COOKING CHAMBER

At the end of a day's work, it is necessary to clean the equipment, both for hygienic reasons and to avoid operating failures.

The oven must never be cleaned with direct or high-pressure water jets.

Similarly, iron cleaning pads, brushes or common steel scrapers shall not be used for cleaning the appliance.

Attention: any fats and food residues present in the cooking room could catch fire while using the oven, so it is advisable to remove them promptly.

- Wait for the cooking chamber to cool.
- Remove the side grills that keep the baking trays.
- Remove any residues that can be removed manually and put the extractable parts in the dishwasher.
- Clean the cooking room with warm water and soap.
- Subsequently, all areas concerned must be accurately
- Rinse, be careful not to leave detergent residues.
- To clean the outside of the oven, use a damp cloth and a mild detergent.

To perform the manual cleaning correctly, follow the following steps:

- Turn on the appliance and set the temperature to 176 °F (80 °C).
- Leave it on for 10 minutes (with steam function, for preset ovens).
- Turn off the appliance and let it cool.
- Remove the supports of the side trays.
- Spray the detergent over the entire internal surface of the oven and wait 10 minutes.
- Rinse the cooking chamber thoroughly at the end of the cleaning cycle.
- It is strictly forbidden to wash the cooking chamber at temperatures above 70°C (158°F). Danger of burn.

9.4 CLEANING OF EXTERNAL SURFACES

Daily cleaning of the covering of the oven cooking chamber must be carried out with a non-abrasive detergent to ensure its proper functioning. Use plastic bristles or a sponge soaked in vinegar and hot water in the case of dry residues.

Use only a damp cloth with hot water or products suitable for cleaning stainless steel. Do not use acid or ammonia products.

ATTENTION: never clean the appliance with water or steam jets under pressure.

9.5 REPLACEMENT OF THE BULB

ATTENTION: Strictly comply with the following procedure to avoid electrocution or damage to persons.

- Disconnect the oven from the mains and let it cool.
- Remove the side supports that hold the baking trays.
- Remove the cover "A", unscrewing the 4 fixing screws.
- Replace the lamp "B" with a lamp having the same characteristics.
- Reposition the lid "A" and fix it again with the screws previously removed.
- Put back the side grids, making sure they are well fixed.

In case the glass lid breaks or damages, do not use the oven until the lid is replaced (contact Customer Service).

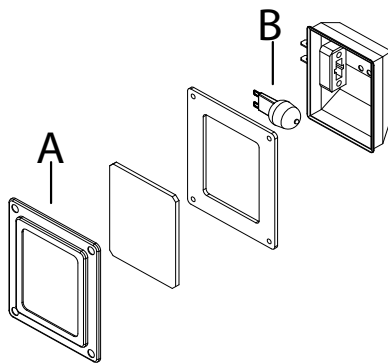

9.6 MAINTENANCE IN CASE OF BREAKAGE

If the appliance breaks down, disconnect it from the mains and turn off the water. Before calling customer service, check the table below.

PROBLEM	CAUSE	SOLUTION
The oven does not start when in START	<ul style="list-style-type: none"> • Door is open. • The microswitch does not signal that the door is Closed. 	<ul style="list-style-type: none"> • Make sure the door is closed. • Contact a specialized technician for repairs (Service Assistance).
The oven light is off	<ul style="list-style-type: none"> • Loose light bulb. • Blown light bulb. 	<ul style="list-style-type: none"> • Insert the light bulb correctly. • Replace the light bulb.
The oven does not cook uniformly	<ul style="list-style-type: none"> • The fans no longer execute inversion. • A fan has stopped. • One of the resistances has broken • A door seal is out of place. 	<ul style="list-style-type: none"> • Contact a specialized technician for repairs (Service Assistance). • Contact a specialized technician for repairs (Service Assistance). • Contact a specialized technician for repairs (Service Assistance). • Correctly reposition the appliance's door seal.
The oven is completely turned off	<ul style="list-style-type: none"> • No main power supply. • Incorrect connection to the main power supply. • Safety thermostat triggered. 	<ul style="list-style-type: none"> • Restore the main power supply. • Check connection to the main power supply. • Contact a specialized technician for repairs (Service Assistance).
Water does not enter the steam tubes	<ul style="list-style-type: none"> • Water inlet is closed. • Incorrect connection to the water supply. • Water inlet filters obstructed by dirt. 	<ul style="list-style-type: none"> • Open the water inlet. • Check connection to the main water supply. • Clean the filters.
Water leaks out from the washer with the door closed	<ul style="list-style-type: none"> • Dirty washer. • Damaged washer. • Problems with the door closing mechanism 	<ul style="list-style-type: none"> • Clean the washer with a damp cloth. • Contact a specialized technician for repairs (Service Assistance). • Contact a specialized technician for repairs (Service Assistance).
The fan stops during operation	<ul style="list-style-type: none"> • Motor safety thermostat is triggered. • The motor capacitor is broken. 	<ul style="list-style-type: none"> • Switch off the oven and wait for the motor's thermal protection to automatically reset. If the problem persists, please contact a specialized technician for repairs (Service Assistance). • Check the safety distance of the oven. • Contact a specialized technician for repairs (Service Assistance).

10. PERIODS OF INACTIVITY

During periods of inactivity, disconnect the power supply and water, remove the tank of the detergent and close them with care. Protect the steel outer parts of the equipment by passing them with a soft cloth just soaked with vaseline oil. Leave the door so as to ensure a proper air exchange.

When restoring, before use:

- carry out an accurate cleaning of the equipment and accessories;
- reconnect the equipment to the power supply, water supply;
- subject the equipment to check before re-use;

In order to ensure that the appliance is in perfect conditions of use and safety, it is recommended that it be subjected to maintenance and control by an authorised service centre at least once a year.

11.END-OF-LIFE DISPOSAL

In order to avoid any unauthorised use and the risks associated with it before disposing of the equipment:

- Make sure that it is no longer possible to use it: for this purpose, the power cable must be cut or removed (with equipment disconnected from the mains).
- To ensure that no child is accidentally trapped inside the cooking chamber for play, to this end block the opening of the door (e.g. with adhesive tape or stoppers).

11.1 EQUIPMENT DISPOSAL

Pursuant to Article 13 of Legislative Decree No. 49 of 2014 “Implementation of the WEEE Directive 2012/19/EU on waste electrical and electronic equipment” The mark of the barred bin with a bar specifies that the product has been placed on the market after 13 August 2005 and that at the end of its useful life it must not be assimilated to other waste but must be disposed of separately. All equipment is made of recyclable metal materials (stainless steel, iron, aluminium, galvanised sheet metal, copper, etc.) in a percentage of more than 90 % by weight.

Attention needs to be paid to the management of this product at the end of life by reducing negative environmental impacts and improving resource efficiency, applying the principles of “polluter pays”, prevention, preparation for re-use, recycling and recovery. Please note that the unfair or incorrect disposal of the product involves the application of the sanctions provided for by the current legislation.

11.2 INFORMATION ON DISPOSAL IN THE EUROPEAN UNION

The EU WEEE Directive has been implemented differently in each country, so if you wish to dispose of this equipment we suggest that you contact your local authority or Dealer to ask for the correct method of disposal.