Installation and User Manual

Touch screen oven series:

EHONP17

Note!

Before use and operation, please read the operation manual carefully and operate in strict accordance with the operation manual. We reserve the right to change the relevant information (including design and parts) in this instruction book without further notice when the product is upgraded or adjusted for use.

Key symbols



DANGER!

This symbol highlights dangerous situations which could lead to serious injury or death



WARNING!

This symbol highlights potential dangerous situations which might lead to serious injury or death



CAUTION!

This symbol highlights potential dangerous situations which could lead to light injury



DANGER!

Be careful. Life is at risk. Failure to comply may result in electrical shock

Introduction

Speed Oven series reduce a lot of cooking time when we compare it with traditional ovens, without compromising with quality.

It is easy for multiply repeated operation once each recipes' parameters are set and stored. It is capable for up to 1024 recipes.

Programmable cooking steps:

Adjustable programming parameters and stages provide various combination to tackle different recipes in order to pursuit high quality result.

Each menu can program **15** stages; each stage can adjust Time, Temperature, Wind Speed and Microwave grades (different model have different features).



Prevent microwave exposure

1. DO NOT open the door during operation, it will cause microwave exposure.
2. DO NOT leave anything between the door seal, must not have any cleansers or other residues on the door seal surface;
3. DO NOT use this device if there is a breakdown. The normal closing of the door body is very important and needs to be checked frequently:
 - 1) Check the door if it is not deformed;
 - 2) Check the door hinges and clasp for cracks and loose;
 - 3) Check the door seals and door seal surface is intact.
4. Only qualified service technician is allowed for repair



Warning:

This is a grade A product, it might cause electromagnetic interference at domestic circumstance. Therefore, some supporting measures are required from user.

Please read all sections of this manual carefully prior to using this oven and retain for future reference.

✘ IMPORTANT SAFETY INSTRUCTIONS

WARNING

Before use and operation, please carefully read the operating manual, and operate in strict accordance with the safety instructions to reduce the risk of burns, electrical shock, fire, personal injury, exposed to overdose microwave radiation

1. READ all instructions before using equipment.
2. READ AND FOLLOW the specific "Important Safety Precautions" on this page.
3. This device must be grounded. The grounding wire must be connected to the appropriate grounding outlet seat (see "Electrical connection");
3. Do not operate the equipment by minors;
4. Read and follow the instructions relating to "Protect against high levels of microwave radiation".
5. Do not remove the cover;
6. Do not remove the parts installed in the interior of the oven;
7. Strictly follow the installation instructions provided on the device to perform the installation and positioning;
8. Only qualified personnel can undertake the maintenance of the equipment. Please contact authorized service providers for equipment inspection, repairs or adjustments
9. Please stop using the oven when the following occurs: The power cord damage / abnormal operation / failure and stop;
10. Do not put the power cord or plug in water, and not close to a heat source.
11. Do not hang the power cord on the table with sharp edges, and do not be pressed by objects;
12. If there is any damage in the power cord, please ask a qualified technician for service.
13. Only suitable containers for the microwave oven are allowed to be used.
14. Do not use this oven for heating liquids or other food with a closed container such as glass bottles and eggs in order to avoid bursting.
15. DO NOT USE THIS DEVICE WITHOUT FOOD LOADING.
16. Do not block the vents, cooling vents, filters and steam ports;
17. Do not put the oven near water and cannot use the oven in wet areas;
18. When cleaning, be careful not to use the corrosive cleaner, otherwise the oven will be permanently damaged;
19. To avoid the risk of fire in the oven chamber. Do not a) over-baked; b) store things in oven chamber; c) before putting the paper or plastic bags into the chamber, all metal seals need to be removed and keep eyes on the operation; d) if the food in the oven is on fire, do not open the door, turn off the oven and cut off the power of the oven;
20. When the liquid food is heated above the boiling point, the surface of the liquid does not always occur boiling. The boiling bubble is rarely been seen under normal circumstances when removing the container from the microwave oven. But shaking the container or putting spoon into the liquid, the liquid will boil violently and overflow. It is very easy to get burnt when this happen.
21. When picking and putting hot drink, food or containers, please pay attention to avoid burns;
22. Do not damage the control panel, door, door seals and other parts, if the door seal is damaged, please ask the qualified service technician for repair;
23. Do not hang clothes or wash cloth in any part of the oven.
24. Before heating the liquid food, stir the food to avoid violent boiling.
25. Baby milk bottles and container of the baby food should not be put into oven for heating;
26. Do not heat wine, such as brandy, rum or any other foods containing alcohol to avoid overheat and fire
27. Oven could not make fried food;
28. This appliance is NOT intended for use by persons (including children) with reduced physical, sensory or mental capabilities, or lack of experience and knowledge, unless they have been given supervision or instruction concerning use of the appliance by a person responsible for their safety.
29. CHILDREN SHOULD BE SUPERVISED to ensure that they DO NOT play with the appliance.

IMPORTANT SAFETY INSTRUCTIONS

Please read this instruction carefully before operation

1. Same as other electric appliance, this product needs an overall checking of electric wiring connection at least once every year;
2. Follow cleaning chapter within this book to clean chamber and door seal frequently, in order to prevent potential fires and leaking hazards;
3. Shut down oven every day after use;
4. Cannot be used for drying cotton and linen;
5. Prevent food catching fire in the chamber while cooking;
6. Transfer food from flammable packages to microwave/oven safe containers before heating;
7. Open its package before heating
8. Egg with shell and other sealed food cannot use this product to heat up otherwise it will have danger of explosion;
9. Food with skin, like potato, apple, sausage, etc. Users should pierce holes or makes cuts on skin before heating by this product.
10. Do not heat the food in the completely sealed container, because the steam generated by heating will cause the container to explode;
11. Remove excess fat from container before taking out from oven;
12. If accident arise, glass container has broken in oven, must check and discard the food if unsure;
13. Under any of following circumstance, DO NOT use this oven: door is stuck, cannot close properly/ door body, hinge, clasp or door seal. CANNOT operate WITHOUT food loading

 If there is smoke

- Shut down the oven
- Cut down main power supply
- Do Not open the door, let fire extinct in the chamber

Chart of Suitable Containers

Manufacturer will list a few containers that allowed under specific conditions below, please check carefully and be aware before use.

Heat-resistant containers		
Tempered glass	√	Containers with metal ornaments cannot be used
Glass ceramics	√	
Pottery (enamel, pottery, ceramics)	√	
Metal plate		
Metal plate (cannot use all the other metal containers)	√	Only on a shelf inside the chamber. DON'T COOK FOOD DIRECTLY ON FLOOR OF OVEN.
Plastic containers		
Special plastic containers suitable for oven use	√	Not able to be used when temperature reach a certain heat. Please refer to the manual of manufacturer
Disposable Tableware		
Do not use flammable container(paper /cardboard)	X	
Foil Paper	X	
Other instruments		
Sealing tap, label	X	When heating, you cannot have any cooking utensils inside the oven.
Tableware	X	
Temperature Sensor	X	

CONTENTS

Key symbols.....	2
Introduction	3
1. Installation	8
1.1 Receipt Note:.....	8
1.2 The location and position of the oven.....	8
1.3 Power supply installation	9
1.3.1 Power supply	9
1.3.2 Power supply installation.....	9
1.3.3 Single phase.....	9
1.3.4 Three phases.....	10
2. Device parameters.....	11
2.1 Product parameters table.....	11
3. Features	13
4. Operation Instruction	14
4.1 Power Connection	14
4.2 Operation interface.....	15
4.2.1. Interface.....	15
4.2.2. Editing Menu.....	16
4.2.3. A quick Customized menu	19
4.2.4 System setting	20
5. Cleaning	26
5.1 Cleaning instruction.....	26
5.1.1 Rapid cool down method.....	26
5.1.2 Cleaning tools.....	26
6. Trouble shooting	27

1. Installation

1.1 Receipt Note:

1. At the time of receipt, check for apparent shipping damage. Contact the shipping company directly if necessary;
2. Open the package, tear off/remove the protective tape from the chamber top AND stainless steel protective film. Then dispose the package waste in a proper way.

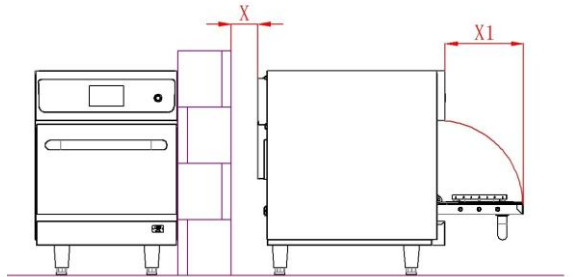

1.2 The location and position of the oven

1. Choose a location far away from heat.
2. Do not place the oven near fryer, Griddle, etc. If the heat sources are next to the oven, a heat shield must be set, which is taller than the oven's height.
3. Place the oven in a non-slip, non-flammable platform, the platform shall be horizontal, stable, and can support the weight of the entire oven.
4. A minimum of 60mm clearance (X) must be left around the oven, with a minimum of 140mm at the top for heat dissipation.
The front of the oven must be adequately spaced (X1) to allow for easy opening and closing.
5. **Air inlet is underneath the oven door, the temperature into the oven is as low as possible, it is very important. If the inlet air is preheated by stove, oven, griddle, fryer, etc. It will reduce the performance of the oven, thereby shortening the life of the oven.**
6. Do not paste any mark or label on the oven except the label with the oven and the label with the manufacturer's permission.

CAUTION!

1. **EXCESSIVE WEIGHT HAZARD.** Handle the oven properly, complying with national or local regulations regarding handling heavy objects, **DO NOT CARRY THE DOOR HANDLE AS THE FOCAL POINT.** Otherwise it will damage the oven or cause injury. Our company will not be liable for any claims arising from falling of the oven, and not responsible for such injury that may cause.
2. When the oven not being used, cut off the power supply, store the oven in a dry, cool place, do not stack up the oven.

1.3 Power supply installation

1.3.1 Power supply

Strongly recommend oven connects to leakage protector, its decoupling current will be not less than 30 mA.

At least choose electrical signal sensitive standard type (B class standard) circuit breaker. Jump signal will occur when user open a freezer, fridge and other appliance (includes microwave). Strongly recommend Circuit Breaker (C class standard), which is designed for products like this oven. While there are many ovens, each must connect to a suitable capacity Circuit Breaker This product adopts EN61000-3-11 standard. It might interfere power supply system, so acquire permission of power supply department before connecting. Where necessary, use low-impedance power supply.

1.3.2 Power supply installation

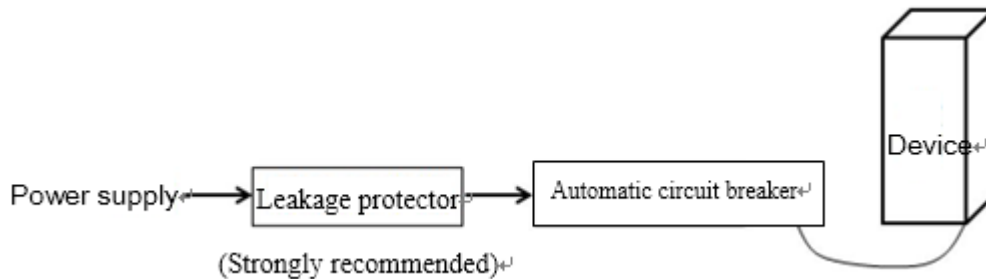

Connect the device to the automatic circuit breaker first and then to the power supply, see the diagram above.

1.3.3 Single phase

The connection of single-phase power supply is shown in the picture.

The UK model is a 32A blue plug with the symbol IEC 60309 (EN 60309).

Rated current of circuit breaker (class C standard) is 40A.

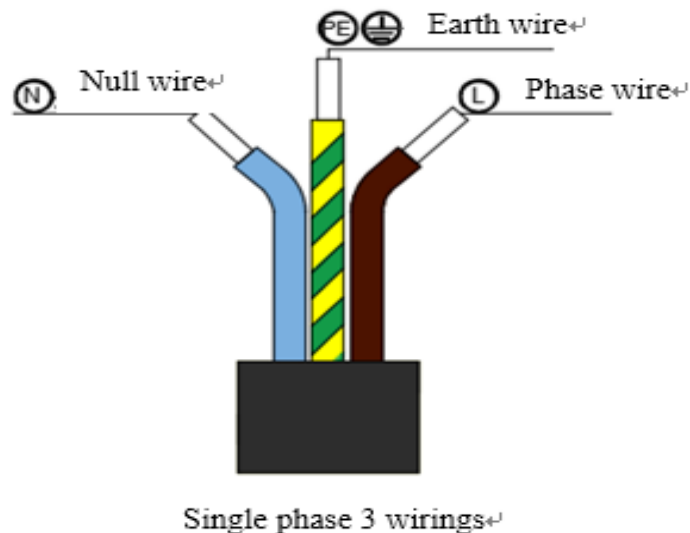

1.3.4 Three phases

The connection of three-phase power supply is shown in the picture.

The rated current of the circuit breaker (class C standard) is 20A per phase.

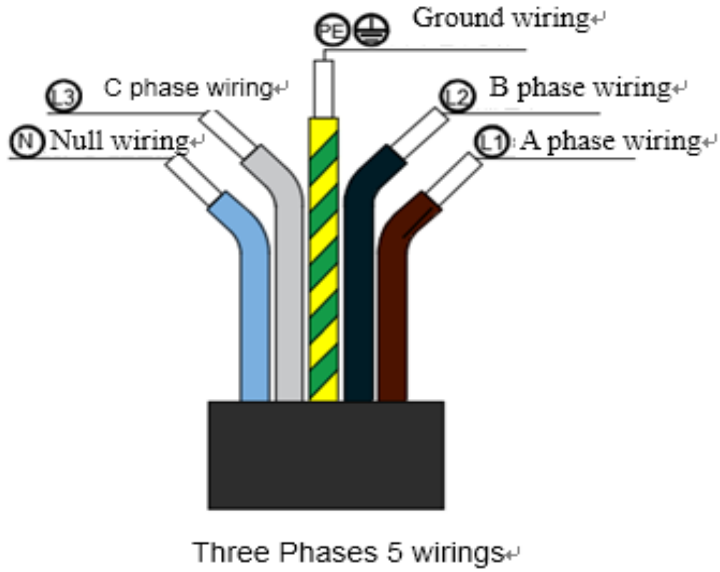

Consult a qualified electrician if doubt exists on electric connection.



Warning!

When connecting the power cord, make sure the connection of each core wire is firm and the power cord is locked tightly. Even if the power cord is affected by external forces, the wiring terminals should not be loose, otherwise it may cause danger. The supply cord shall be oil-resistant sheathed cable, not lighter than that of ordinary neoprene or other equivalent synthetic rubber sheathed cord. If the power cord is damaged, it must be replaced with one of the same specifications



Warning!

If the power supply is outside, please pay attention to the water proof and dust proof measures



Warning!

To avoid the risk due to worn power cord, bushing must be installed at the outlet of the power cord and at the hole through which the power cord passes



Danger!

This product must be grounded, or it may cause electric shock or even death. The electrical wiring of the equipment must be connected to a separate power supply by a qualified electrical technician. Each device must be fitted with a double-way insulated switch with an appropriate rated capacity and contact spacing more than 3mm



Warning!



When connecting the ground wire, ensure that the power cord is connected to the ground wire terminal when acted upon by external forces



Equipotential

The back of the equipment has an equipotential ground point for separate grounding (GND)



Caution!

When the length of the power cord is insufficient, please REPLACE with a new power cord with sufficient length. DO NOT CONNECT TWO POWER CORDS TOGETHER FOR EXTENSION

2. Device parameters

2.1 Product parameters table

Model	EHONP17
Dimension(mm)	460X675X660
Chamber(mm)	305X305X185
Capacity(L)	17
Net Weight(KG)	66
Voltage(V)	208-240V~

Frequency	50/60Hz
Rated Power(KW)	3.3
Controller	5" Touch Screen
Menu Storage	1024
Cooking stage	15
Cooking Mode	Hot Air Impingement+ Microwave
*Microwave power (KW)	1.2
Hot air power	3
Microwave range	0-100%
Wind grades	10
IPX Rating	IPX3
Max. Temperature	280

Approximation microwave power output

3. Features

1. Turn On/ Off Power switch

Touch screen will be light up. Notice: Turn off switch does not mean cut off internal power supply;

2. Touch Screen controller

Details please refer to "Operation Instruction" section;

3. Rating plate

Locate at the back, it contains product model, series number, and power specification;

4. USB connector

Easily change to the menu stored in the oven, there is a USB connector underneath the front door;

5. The vent

Locate at the back. The air flow is used to cool the internal components and the steam discharged from cooking chamber. Do not block the vent, it won't cause the microwave leakage into the environment.

6. Air filter

Locate underneath the oven door. It plays an important part in air circulation, so DO NOT block it and follow daily cleaning instruction;

7. The door handle

It is a rigid structure, the oven door can be opened and closed when the handle is pulled down and pushed up from the outside; NEVER CARRY THE DOOR HANDLE AS THE FOCAL POINT.

8. Door

The door has 3 safety interlocking micro-switches. Please Keep the door clean and intact; (Refer to cleaning section)

9. Convection fan, grease filters and catalytic converters (depending on the model).

The grease filters in front of the convection fan must be kept clean and free of debris, etc. Different oven has different procedures for this part. Please pay special attention. Please refer to the "cleaning and maintenance" section in this manual for details.

10. The chamber is made of stainless steel. Please follow the instructions in the "cleaning and maintenance" section of this manual.

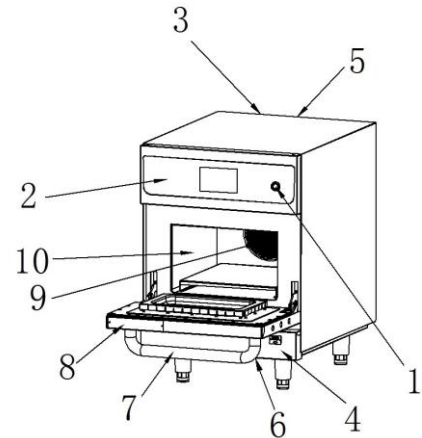

USB port location

It locates underneath the front air filter.

Step 1: Take off air filter

Air filter is mounted with cover by magnet;
pull out with some strength;

Step 2: Open USB dust cap

Rotate left or right to open

Step 3: Insert U disk to download or upload recipe,
picture, etc.

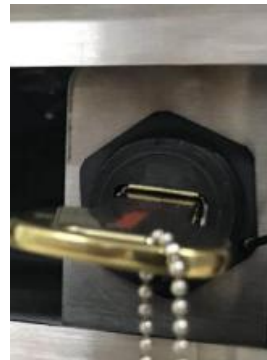

4. Operation Instruction

4.1 Power Connection

Steps	Action	Reference	Details
1	Connect to main power		Single phase 3 wirings/ Three phases 5 wirings
2	Switch on power button		Switch on power button, screen light on, enter stand-by mode

4.2 Operation interface

4.2.1. Interface

1. Switch on power button, screen light up, enter standby interface as below:

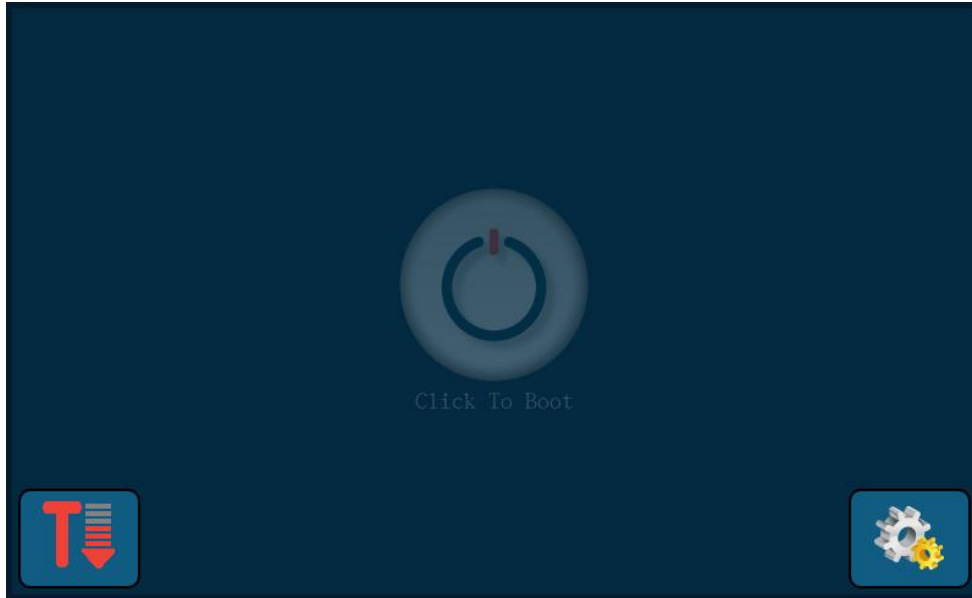

Cooling Mode, when cavity temperature is over 70°C, follow notice window to open the door meanwhile fan keeps working; when temperature drops down to 70°C, it automatically

exits back to standby interface, or you cancel cool down mode by pressing



2. Press  , enter main interface:



: Set Preheat temperature, press this



: Switch off button, it requires a long press to return back to standby interface

4.2.2. Editing Menu

1. Tap on dish photo to enter setting:



: view parameters of each stage.

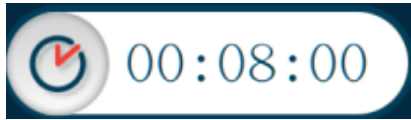

: Click on timer to edit cooking time for this time, not saved;



: Click to edit cooking temperature for this time, not saved;



: Hold pressing this icon can view real cavity temperature.



: Continually tap to change microwave percentage. (0%-100% then recycle)



: Click to adjust wind speed.



: Preheating



: Preheating finish, ready to cook



: Temp is

higher than preset, cooling down



: Return, back to main interface



: Start

cooking.  : Microwave

2. Tap on start cooking icon, enter cooking screen:

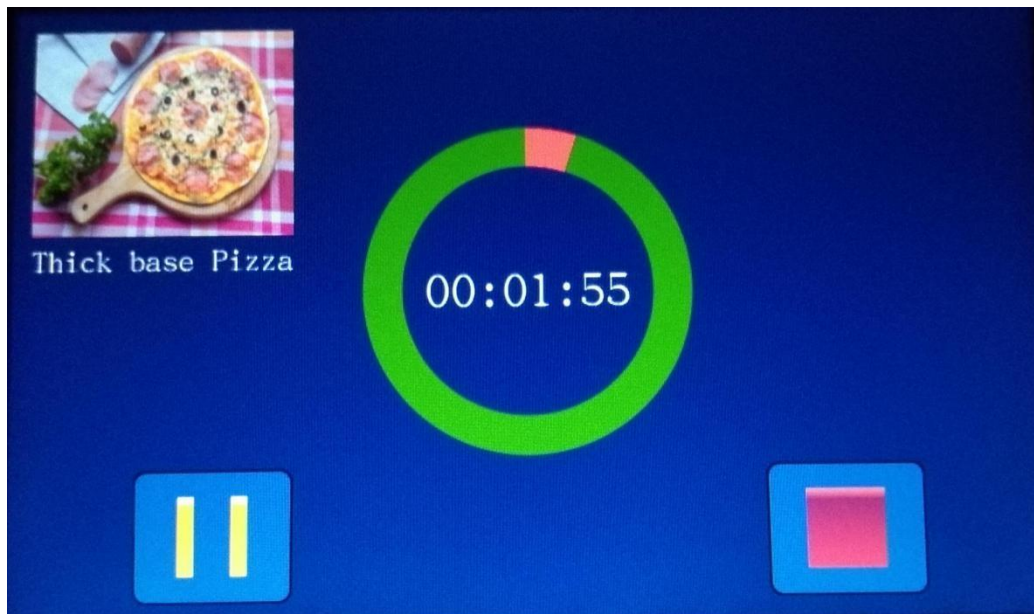

 : Pause/Resume, Pause/resume cooking process

 : Stop, Exit cooking

 Caution:

Open the door during cooking process will result in warning sound and pop up notice” DOOR OPEN”, but it will continue cooking after closing the door.

If the temperature has not reached to preset temperature, system will pop out this:



If click on ✓, but did not open door and place food inside oven. System will soon display this window:

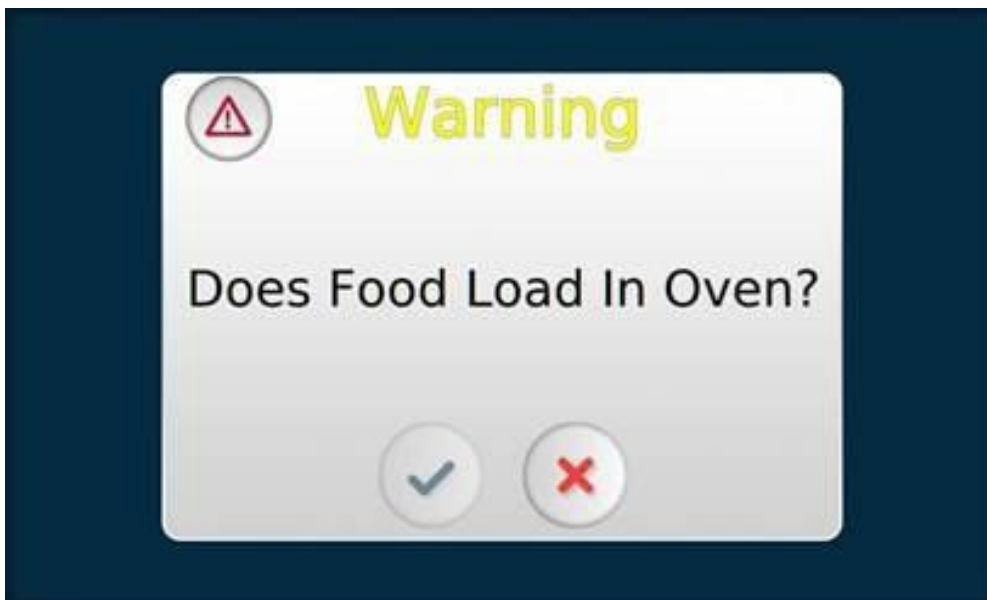

3. Finish cooking, it will pop up a window. Click "+10" to add 10 second increment at a time, as below



4. When door is open, it will appear a warning notice as picture:

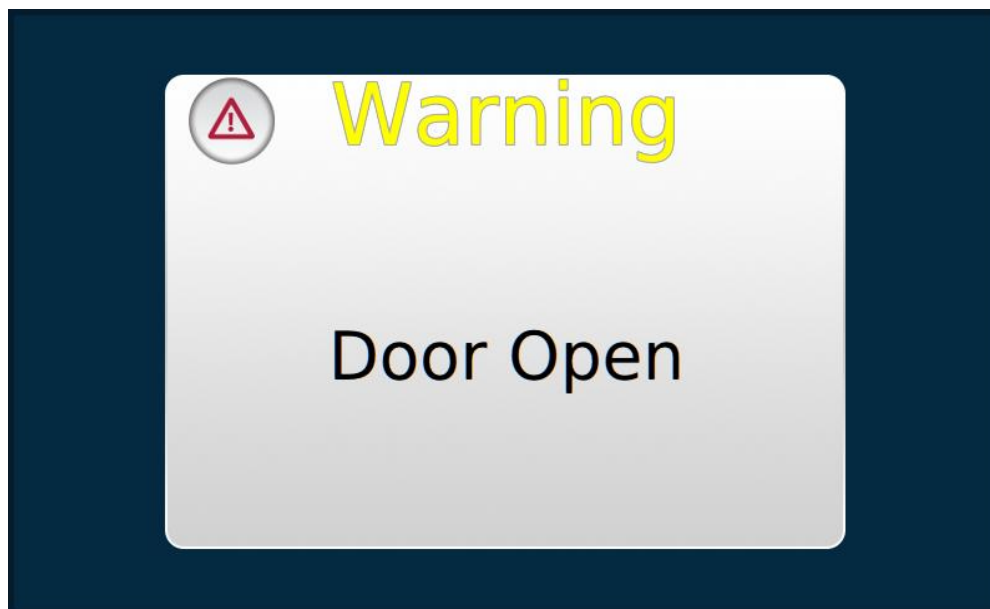

4.2.3. A quick Customized menu



: Customized mode used for recipes testing and development, all parameter are editable.

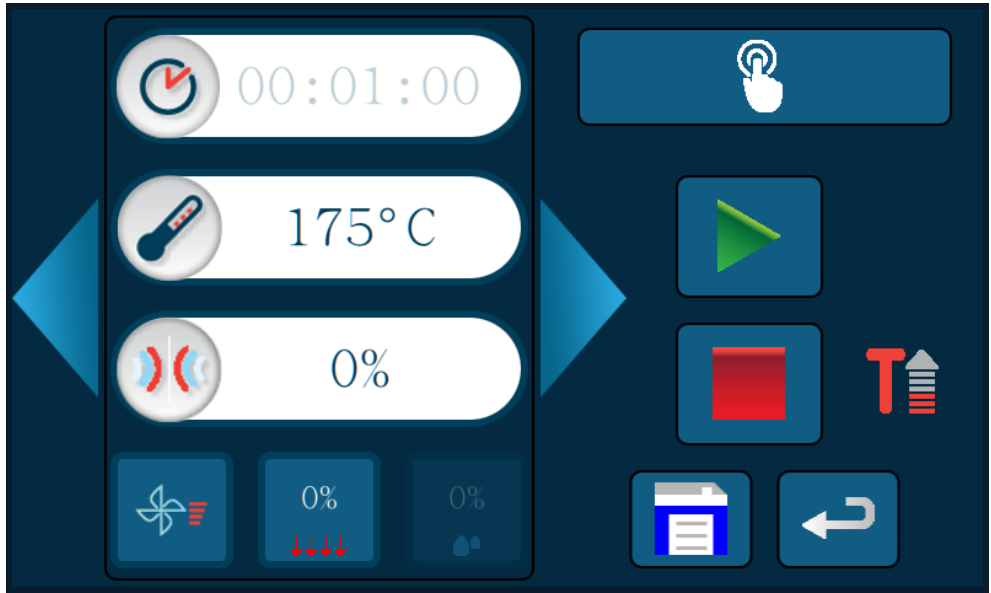

Click on , add another cooking stage.

After finish, click  to save it.

4.2.4 System setting

 : click to enter system setting interface:

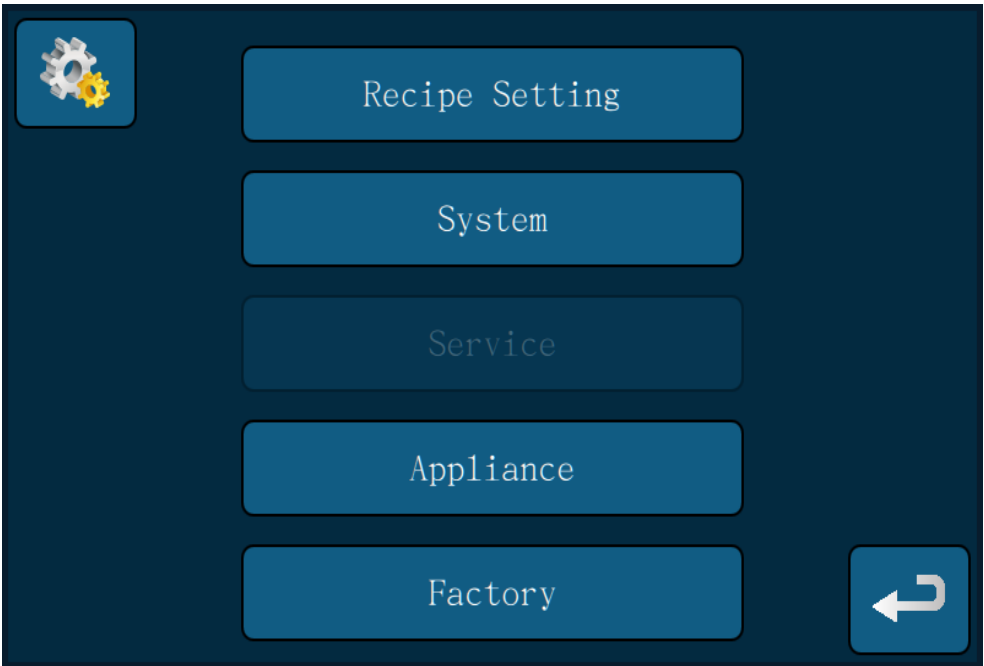

1. Click "Recipe Setting", enter screen like below:

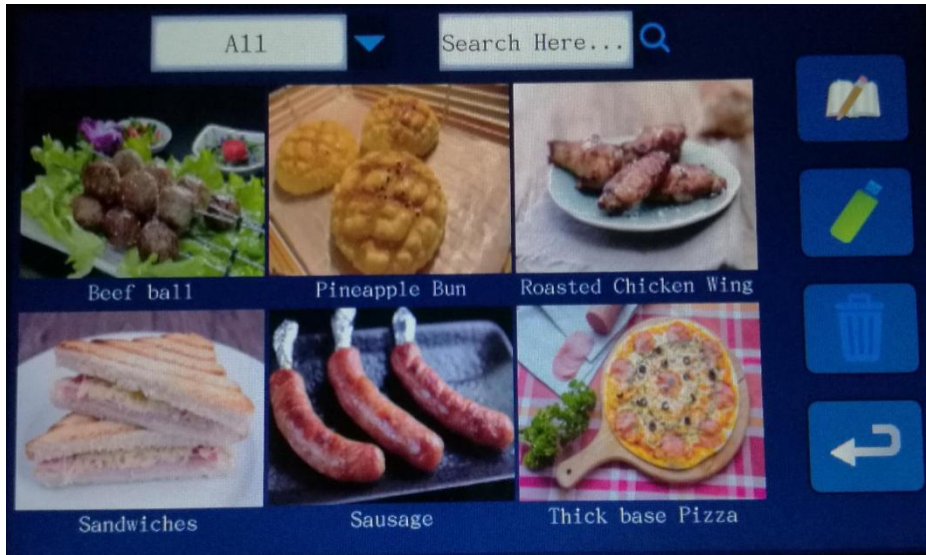

: Read & Write Recipe. Write: copy USB recipes into Oven; Read: copy Oven recipes into USB;



: Delete Menu;



: Set up a new menu, click into a screen like below:

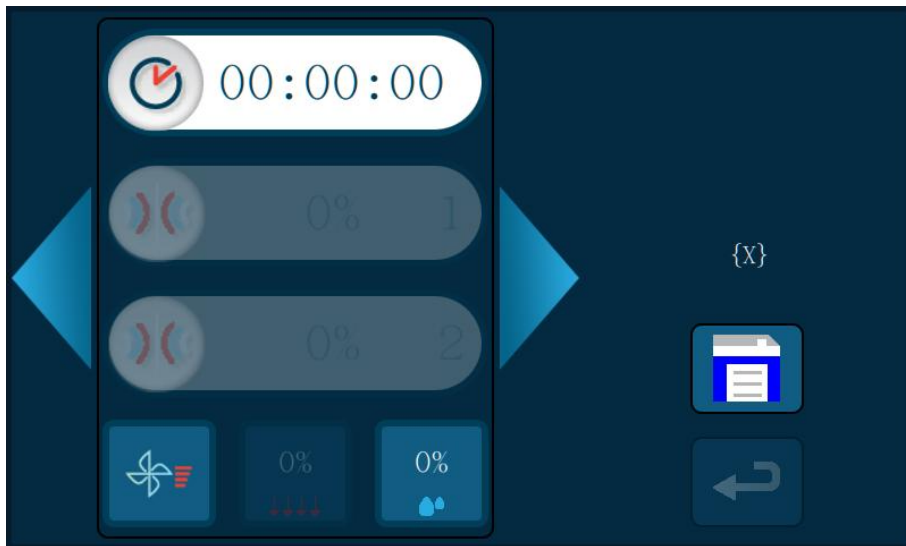

Click to edit every factor accordingly, then click  to enter into the second cooking stage as

per requirement. It has maximum **15** cooking stages. Once finish setting, click  for

saving. The screen will be like this:

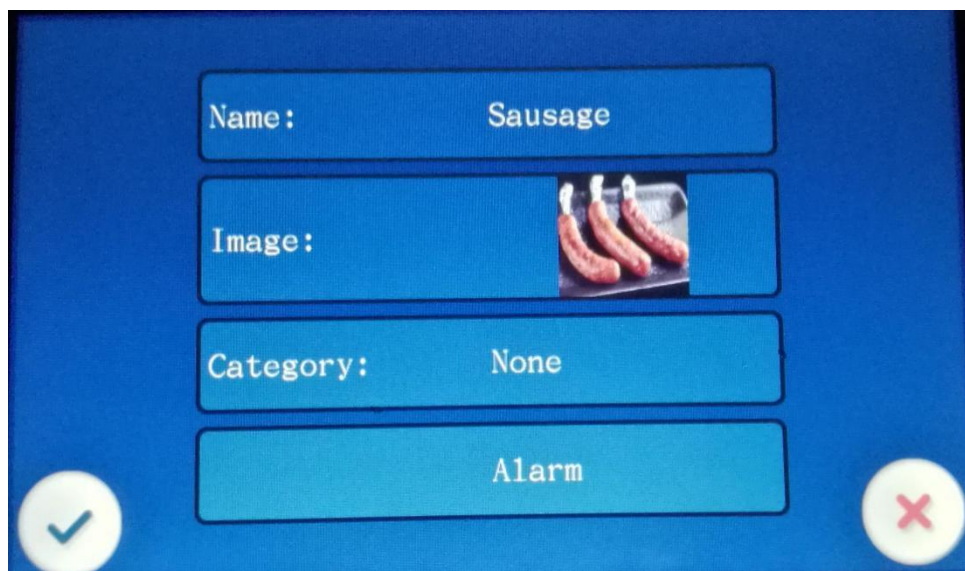

Click to add dish picture. Category range from breakfast, lunch, dinner, supper and all day. You can click on name to edit name for this recipe as well, like below:



Can use pinyin input Chinese name, or directly input English name; Direct input letter can input English, if input pinyin, then need to select Chinese text.

If you have more than 2 stages, you can set alarm for each stage, except the last stage. Click on "Alarm" to set alarm as below:

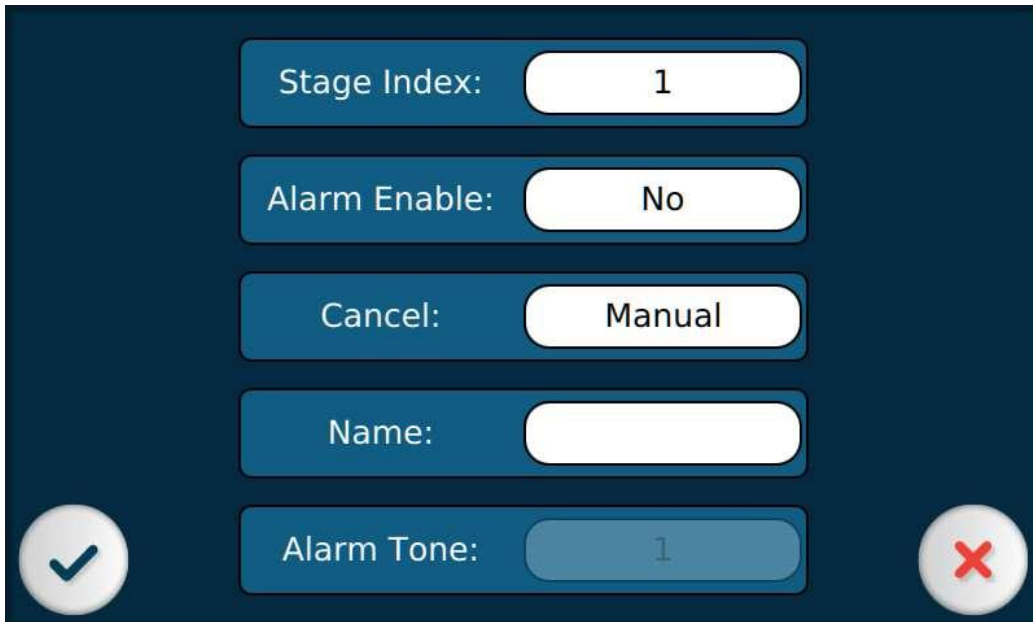

“Stage Index” can choose to set alarm for stage 1, 2, 3 (if you have more than 3 stages);
 Alarm Enable: click on “yes” ; click on “cancel” can select means of cancelling alarm,
 either manual or automatic; click on “name” to **edit name** for this alarm (**Must set!**).
 Manual: When alarm rings, there must be a physical action to stop alarm
 Automatic: After ringing for a few seconds it will automatically stop

After setting, click on  to save menu.

2. Click system to enter system setting interface:

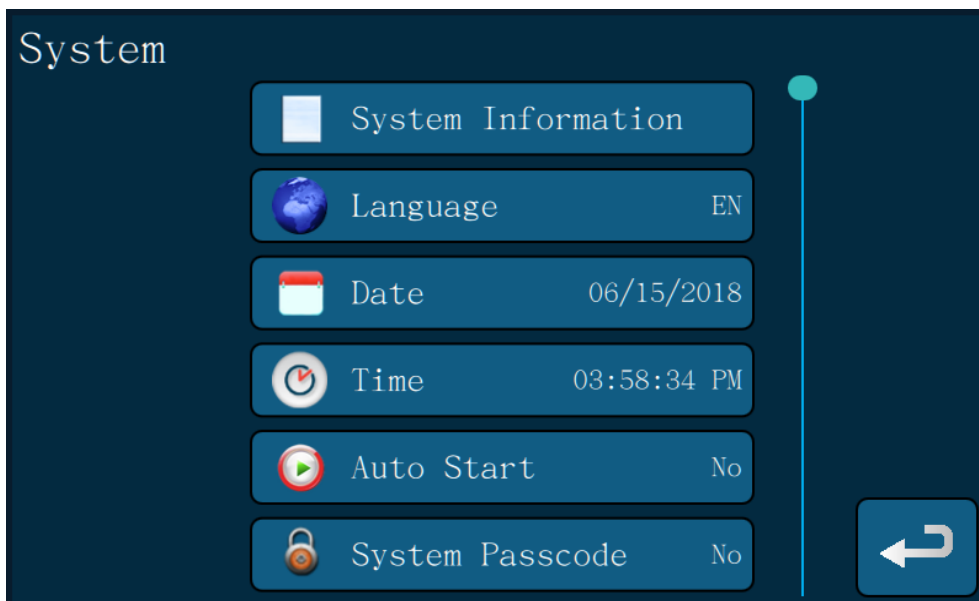

“Language”, click on EN or Chinese can select English and Chinese.

“Date”, click on date can edit the date which show on the screen

“Time”, click on time can change time which shows on the oven

“Auto Start”, click to set an auto start time for cooking a recipe

“System passcode”, set up password for entering system setting

3. Click “Service”, the password is ***** (please contact the dealer or manufacturer to obtain password authorization)

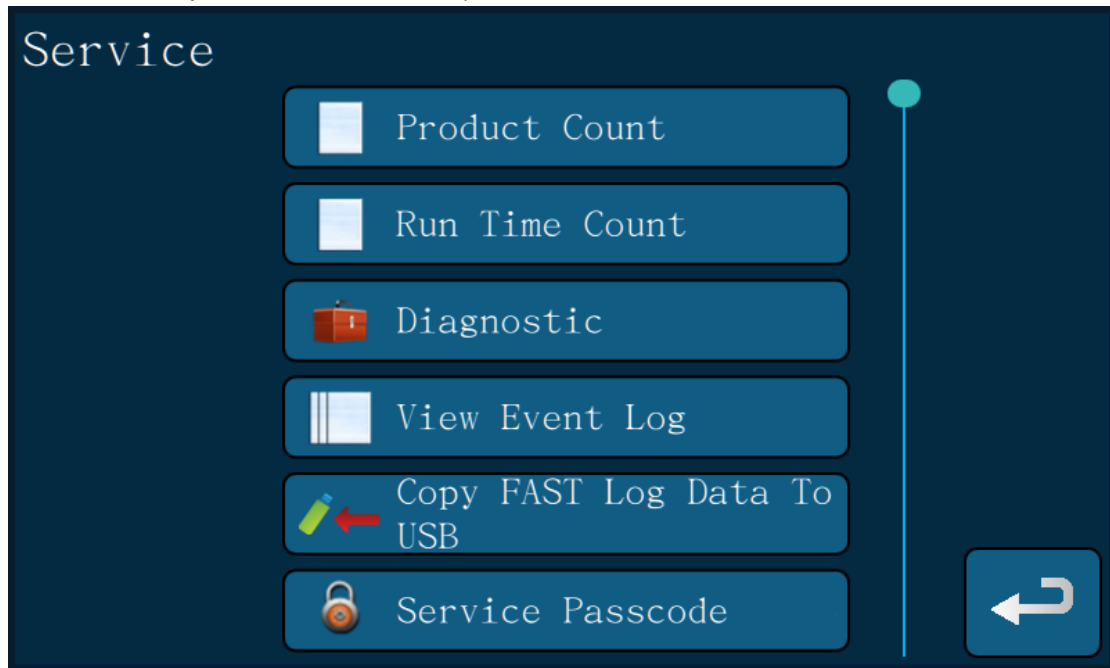

“Product Count”, click here to view how many times of using every menu

“Run Time Count” , total running time of all parameters record, for example “Power on time”

“Diagnostic”, diagnostic screen for device technical maintenance

“View Event Log”, operation malfunction will be recorded into this Log

“Copy Fast Log Data to USB”, download log data into USB.

“Service Passcode”, ***** (please contact the dealer or manufacturer to obtain password authorization). Can setup passwords to enter into this management page and block unauthorized entry.

4. Click “Appliance”, password is “*****” (please contact the dealer or manufacturer to obtain password authorization) enter into this interface:

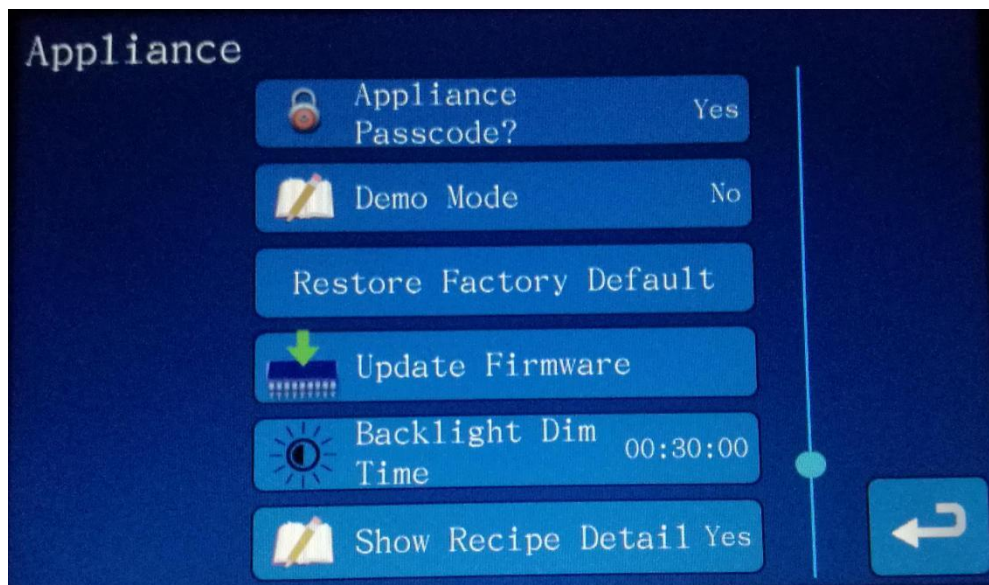
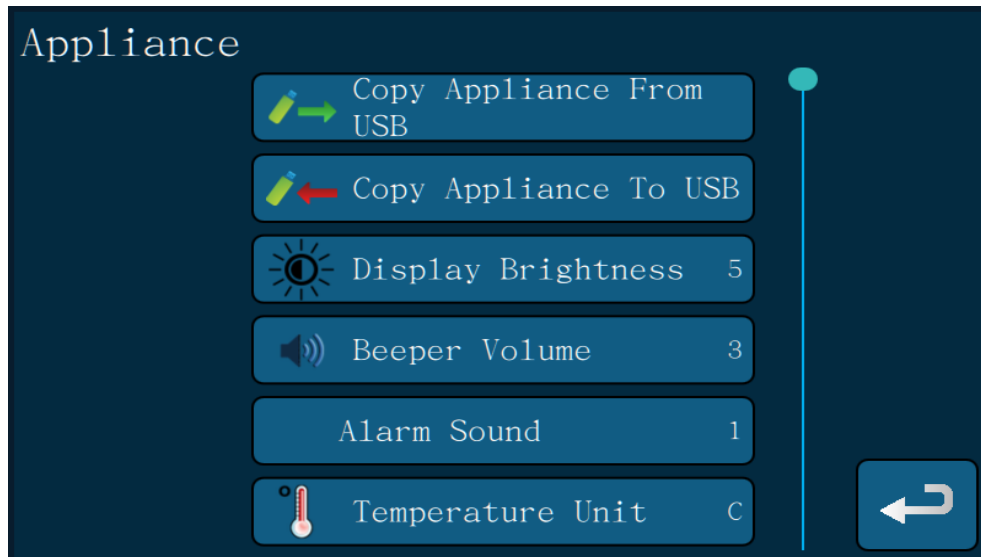

“Copy Appliance From USB”: copy appliance data from USB to Oven

“Copy Appliance To USB”: copy appliance data from Oven to USB

“Display Brightness”: higher of the number is brighter

“Beeper Volume”: volume for alarm, higher is louder

“Alarm Sound”: alarm tone

“Temperature Unit” : interchange between °C and °F

“Edit Recipe image”: manage recipe picture, add or delete

“Recipe Passcode”: once set up, it will be required to key in before entering into recipe parameter page

“Appliance Passcode”: administrator password to enter Appliance setting

“Demo Mode”: “yes”, only touch screen is working for demo, no heating function. “no”, touch screen and heating function both working

“Restore Factory Default”: reset back to factory setting

“Update Firmware”: Upgrade or repair software, restore, backup and renew apps

“Backlight Dim Time” adjust time to dim the screen brightness

“Show recipe detail”: set “NO” to hide parameter details of cooking

“Use Expiration”: Set the usage period of the device. When the time is up, you need to enter the password to enter the work page of the touch screen.

5. Cleaning

5.1 Cleaning instruction

⚠ WARNING: MAKE SURE APPIIANCE IS UNPLUGGED AND COOLDOWN BEFORE CLEANING

⚠ Warning: Must have cool down process for oven and components before cleaning, otherwise it will cause burn injury

5.1.1 Rapid cool down method

At Stand-by mode, press  device enter rapid cooling process. Open oven door. When temperature drops to 70°C automatically exit

⚠ Note! Do not clean oven during its cooling. The whole process approximately requires 30 minutes.

⚠ Warning: The maximum temperature of this oven can be up to 280 °C, if not proper cooling might cause body injuries.

Cleaning purpose

In order to ensure oven’s high efficiency, Chamber, air filter and oil filter need to be cleaned every day. Daily cleaning can make sure it reach hygiene standard and extend its life time.



5.1.2 Cleaning tools

Non-corrosive oven use cleanser, heatproof gloves, rubber gloves, non-abrasive nylon scrub pad, cleaning cloths and rags, goggles and dust masks

Caution: When cleaning the oven, please wear rubber gloves. Do not use sharp tools and strong abrasive cleaning on any part of the oven.

⚠ Caution: DO NOT use caustic cleanser on any parts of the oven, if not it will result in permanent damage to this oven.



6. Trouble shooting

This section provides an easy reference guide to some of the common problems that may occur during the operation of this equipment. The troubleshooting guides that follow are intended to help correct, or at least accurately diagnose, problems with this equipment. Although the chapter covers the most common problems reported, you may encounter problems that are not covered.

When troubleshooting a problem, always use a process of elimination starting with the simplest solution and working through to the most complex. Never overlook the obvious – anyone can forget to plug in a cord or fail to close a door completely. Most importantly, always try to establish a clear idea of why a problem has occurred. Part of any corrective action involves taking steps to ensure that it doesn't happen again. If a controller malfunctions because of a poor connection, check all other connections, too. If a fuse continues to blow, find out why. Always keep in mind that failure of a small component may often be indicative of potential failure or incorrect functioning of a more important component or system.

DANGER

This equipment should be unplugged when servicing, especially when electrical circuit tests are required. With extreme care when performing such tests. This appliance may have more than one electrical power supply connection point. Disconnect all power cords before service. Inspection, testing, and repair of electrical components should be performed by an authorized service agent only.

Symptom	Possible reason	Treatment
Oven has not electricity	Main power is disconnected	Turn on the main power and restart the oven
	Oven plug cord has not plug in	Check if it is plugged in
	Hi-limiter is tripped	Hi-limiter locates at the back of oven, reset it and reboot the oven
Oven does not heat up	The door is not closed properly.	Clear barrier, close the door properly.
	Does not switch on oven	Switch on oven and heat up
Close door but it still pop up "Door Open" notice	Food block the door from closing	Clean barrier, close the door properly.
	Did not close the door properly	Repeat open and close to check if it is properly close
	Door interlock switch is malfunction	Call for service support
The foods are not cooked well or up to standard	Oven is dirty (a lot grease, carbon and food debris will wear down microwave)	Follow cleaning instruction to clean up
	Choose wrong menu	Check if have chosen the correct menu or program
	Food was not at the right initial condition (Frozen or chilled)	Make sure it is at the suggested condition before put into oven

	Food SPEC is not correct	Ensure food weight and size are standard
Shown temperature probe is broken	Temperature probe is malfunction	Call for service support
Cooking temperature is low	Check if these following part are blocked: Jet plate, return air inlet, oil filter	Cleaning daily to ensure they are not blocked ⚠️ Note: there is no warranty for glass or ceramic oven parts.
	Oven did not heat up completely	Heat up oven to preset temperature and leave it idle for 5 minutes
	Heating element is malfunction	Call for service support
Magnetron is too hot	Cool air did not enter into oven	Remove substance and dust that are blocking air filter at inlet
Motor blower is too hot	Cool air did not enter into oven	Remove substance and dust that are blocking air filter at inlet