

Ice-cream Cart

PLEASE READ THE OPERATION MANUAL BEFORE USING.

SAVE THIS MANUAL FOR LATER USE.

INHALT

Inhalt	2
Teile und Merkmale	3
Gelatowagen (Vitrine) Sicherheit	4-6
Transport- und Installationsanweisungen	7
Betrieb der Vitrine	7-8
Pflege und Wartung	9
Technische Daten und Störungen	10

Teile und Merkmale

SPEWHA3

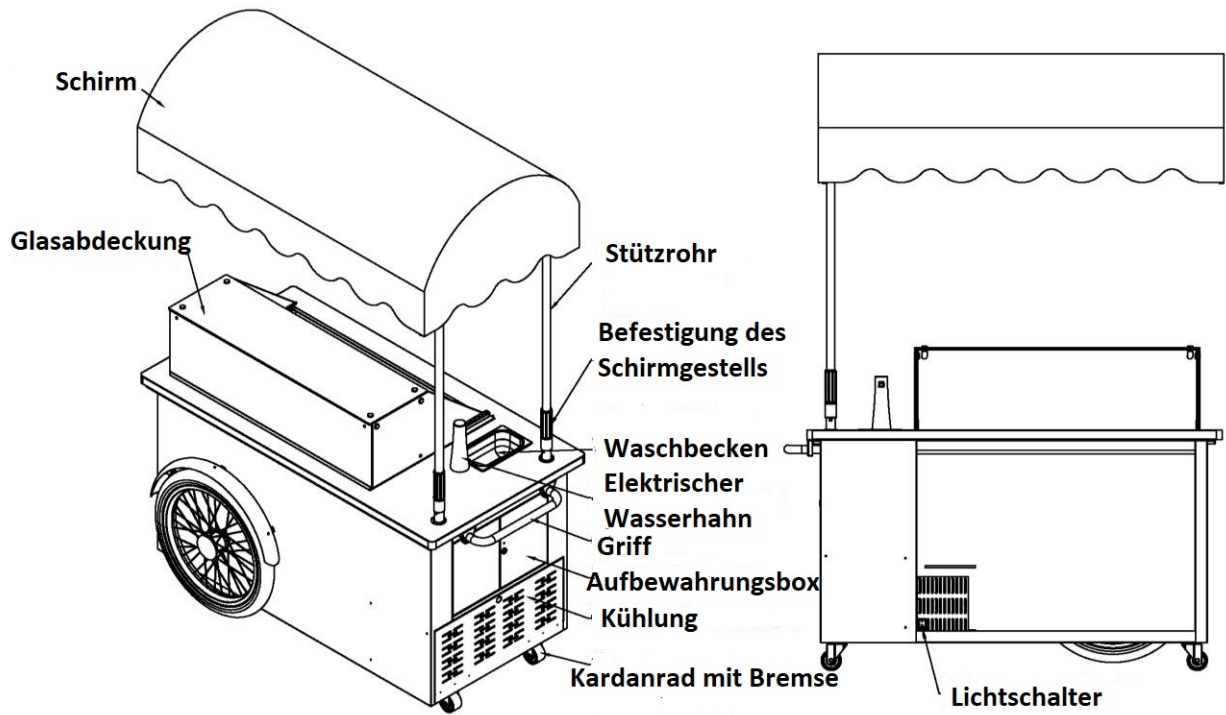

SPEWF6

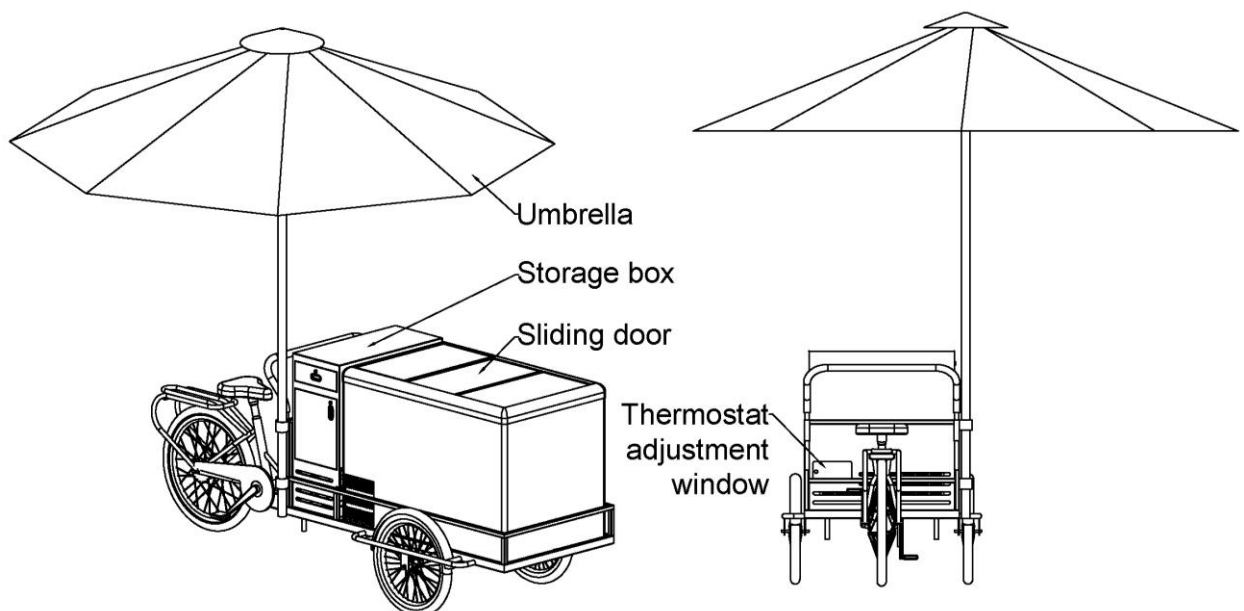

SHOWCASE SAFETY

Your safety and the safety of others are very important.

We have provided many important safety messages in this manual and on your appliance. Always read and obey all safety messages.



This is the Safety Alert Symbol. This symbol alerts you to potential hazards that can kill or injure you and others. All safety messages will follow the Safety Alert Symbol and either the words "DANGER", "WARNING" or "CAUTION".



Danger means that failure to heed this safety statement may result in severe personal injury or death.



Warning means that failure to heed this safety statement may result in extensive product damage, serious personal injury, or death.



Caution means that failure to heed this safety statement may result in minor or moderate personal injury, or property or equipment damage.

All safety messages will alert you to what the potential hazard is, tell you how to reduce the chance of injury, and let you know what can happen if the instructions are not followed.

IMPORTANT SAFEGUARDS



Before the chest showcase is used, it must be properly positioned and installed as described in this manual, so read the manual carefully. To reduce the risk of fire, electrical shock or injury when using the chest showcase, follow basic precautions, including the following:



- This appliance is not intended for use by persons (including children) with reduced physical, sensory or mental capabilities, or lack of experience and knowledge, unless they have been given supervision or instruction concerning use of the appliance by a person responsible for their safety
- Children should be supervised to ensure that they do not play with the appliance.
- **DANGER or WARNING:** Risk of child entrapment: Child entrapment and suffocation are not problems of the past. Junked or abandoned showcases are still dangerous, even if they will “just sit in the garage a few days.”
- **Before you throw away your old showcase:** Take off the doors. Leave the shelves in place so that children may not easily climb inside.
- Please according to local regulation disposal of the appliance for its flammable refrigerant and blowing gas.
- The showcase must use the separate pin outlet to be connected with earth correctly, never with the heating pipe and coal gas pipe.
- The showcase shall be positioned so that the plug is accessible.
- If the supply cord is damaged, the manufacturer of its service agent or a similarly qualified person must replace it in order to avoid a hazard.
- Do not attempt to repair or replace any part of your chest showcase unless it is specifically recommended in this material. All other servicing should be referred to a qualified technician.

WARNING

- The showcase should not be located next to ovens, grills or other sources of high heat.
- Keep ventilation openings, in the appliance enclosure or in the built-in structure, clear of obstruction
- Do not use mechanical devices or other means to accelerate the defrosting process, other than those recommended by the manufacturer
- Do not damage the refrigerant circuit
- Do not use electrical appliances inside the food storage compartments of the appliance, unless they are of the type recommended by the manufacturer
- Before proceeding with cleaning and maintenance operations, make sure the power line of the unit is disconnected.
- Do not connect or disconnect the electric plug when your hands are wet
- Do not store or use gasoline or any other flammable vapors and liquids in the vicinity of this or any other showcase. Never clean showcase parts with flammable fluids. The fumes can create a fire hazard or explosion.
- If the voltage is unstable, please choose the suitable automatic voltage regulator
- Connection the power to check the showcase before using, the showcase can be used until the temperature decreases obviously after 30 minutes
- You should adjust the temperature control according to the requested temperature and quantity of the stored food and the environmental temperature.
- Before putting the stuff into the showcase please adjust the temperature control to the lowest point and let it work till the temperature of inner cabinet decreases to -18°C and then putting the stuff in, after 12 hours adjust the temperature control to the normal point.
- Never put hot food in the showcase directly only after it has been cooled naturally outside
- The stuff should be put into the showcase partially, each lot will not be more than the figure which is equal to the capacity(L) divide by 20
- Not full the showcase and make it crowded, big meat should be divided into several small parts. There should be reasonable space between the foods for better freezing
- If power cut off is needed, you should wait for at least 5 minutes before turn on again to avoid damage to the compressor.
- The stuff stored should be packed with plastic bag well to avoid smell-mixed and moisture-lost, and reduce the frost at the small time
- Beer, beverage, fresh flower, medicine and injections can not be put into the showcase
- Please make the temperature control to the lowest point if you want to store ice cream or other uneasy-frozen food
- We have a policy of continuous improvement on our products and reserve the right to change materials and specifications without notice. To confirm the specific parameters, please accord to the rated label on the product
- Shall, when the product scrap/recovered by professional scrap/recycling locations to deal with.
- This product application environment temperature up to 32°C.

TRANSPORTATION AND INSTALLATION INSTRUCTIONS

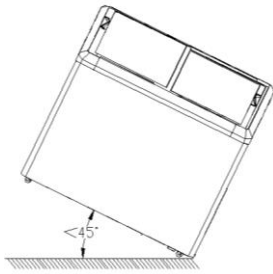

1. When you transport the showcase, the angle between the compartment body and the ground should be no more than 45° and you should never place the showcase up-side down.
2. Do not use any of the external part as loading points, for example, the condenser on the back, the door.
3. When the showcase is installed or used, all the package (including board and foam plastic) should be got rid of.
4. Keeping the showcase stable to avoid vibration and noise.
5. The showcase should be installed in the place with good ventilation, a space of at least 10cm should be allowed between the surrounding walls and the cabinet wall for air condition.
6. It should be placed far from heating resource and not under direct sunshine to avoid decrease of the efficiency of refrigeration.
7. Install the showcase in a dry place so as to prevent rust on the compartment body, which may affect the electric insulation.

OPERATING YOUR SHOWCASE

THE FUNCTION OF CONTROL PANEL:



There are totally 3 button.

1. button (SET)

In normal, press more than 3 seconds, will be enter the parameter menu.

In this process, the parameter name and parameter are displayed alternately when you press button. If press button more than 3 seconds, will save the setting.

Press "SET" and "☺", defaults will be restored, show "CF".

2. button 

In parameter menu, press this button can move to next one, or increase the parameter value.

3. button 

In parameter menu, press this button can return to previous one, or reduce the parameter value.

Press more than 3 seconds, it can enter or exit the defrosting state. (If D1=0, Unable to enter the defrosting state)

STORAGE:

1. The appliance is suitable for storing ice cream and ready-frozen foods.
2. It must not be filled higher than the stacking mark on the inside of the showcase.
3. If there is no load line sticker, please take the top of placed basket as standard.

LOAD LINE**DEFROST:**

1. Defrost when the frost thickness on the wall of the cabinet reaches 5mm to optimize the freezing capacity.
2. Turn the temperature control to the lowest point for 5-6 hours before defrosting.
3. Cut off the power and take out the food, use the defrost removal, do not apply sharp tools.
4. After defrosting, clean the wall with dry cloth, and then power on.

THE FOLLOWING PHENOMENA ARE NORMAL:

1. There will be sound of flowing water when the refrigerant is running.
2. The frozen food do not melt even if a long time power off.
3. When the environment humidity is too high, there will be dew condensed on the surface of the showcase.
4. When the machine is running, the condenser and compressor will be hot.

CARE AND MAINTENANCE

MAINTENANCE AND CLEANNESS:

1. Do not open the door frequently and too long to save energy.
2. Never leave heavy or hot stuff on the top of the showcase to avoid deforming.
3. Cut off the power before cleaning.
4. To clean the showcase, please use soft cloth dampened in some moderate detergent and hot water.
5. Use warm water to clean oil or fruit juice stain on the magnetic gasket in order to keep its elasticity. Apply some talcum powder to it to prolong its service life.
6. The showcase should not be left unused for a long time, to stop using the showcase, disconnect the main power first, then clean the inside and leave the door open for 2~3 days to dry it.

Correct Disposal of this product

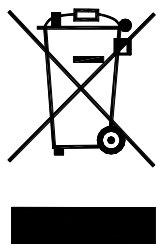

This marking indicates that this product should not be disposed with other household wastes throughout the EU. To prevent possible harm to the environment or human health from uncontrolled waste disposal, recycle it responsibly to promote the sustainable reuse of material resources. To return your used device, please use the return and collection systems or contact the retailer where the product was purchased. They can take this product for environmental safe recycling.

TECHNICAL DATA and PROBLEMS

TECHNICAL DATA:

Model	Effective Volume (L)	Climate Class	Net Weight (kg)	Overall Dimension (mm)	Power	Refrigerant
SPEWHA3	256	N	145	1570*862*2276	220~240v/50Hz	R290/90g
SPEWF6	256	N	126	2665*950*2600	220~240v/50Hz	R290/90g

TROUBLE SHOOTING:

TROUBLES	REASON	SOLUTION
Unfreezing	*Temperature control is on the highest point	Adjust the temperature
	*Plug and outlet not connected well	Make they two connect well
	*Fuse broken off	Change the fuse
Compressor can not stop working	*Temperature control is on the lowest point	Adjust temperature control
	*Too much stuff stored in one time	Reduce the quantity
	*Thick frost	Defrost
	*Too much times of door-opening	Reduce the times of door-opening
	*Too near the wall	Far from the wall
Big noise	*Near the hot source or sun	Change the place
	*Ground is not flat	Change the place
	*Refrigerating tubes connected	Separate them

REMARK: *If you can not solve the troubles according to the above-mentioned ways, please contact the after-sale service, do not handle it yourself.*