



WARNING!

Please read the user manual carefully before using the machine.

USER'S MANUAL

1. Description

The product is the cooling facility special designed for hotel, restaurant, supermarket, cake house to show cake, soft drink, food etc..

It has handsome appearance quality material, vacuum movable door, transparent glass and inner light. Cooling system adopted famous brand of whole close cooling compressor and all kinds of spare parts.

Therefore, the product has the strongpoint of handsome appearance, rational design, quick cooling, electric saving, low noise, no frost and suitable temperature.

2. Main technical data

Model	Net Volume	Temperature	Voltage/ Frequency	Input power	Refrigerant/ Injected Rate	Dimension	N.W
KTH9713R	380L	2-10°C	220-240V/ 50Hz	0.400kw	R290/65g	900*740*1300mm	150kg
KTH12713R	505L			0.445kw	R290/95g	1200*740*1300mm	180kg
KTH15713R	635L			0.515kw	R290/145g	1500*740*1300mm	210kg
KTH18713R	780L			0.560kw	R290/149g	1800*740*1300mm	xxx

3. Safety attention

- (1) You must use single-phase three poles power socket, its grounding E must be grounded reliably.
- (2) Forbid stocking volatile, erosive, radioactive, flammable, explosive, poisonous and polluted dangerous food.
- (3) Please don't put power wire on aisle to prevent heaving pressure and edge tool from creepage accident.
- (4) Don't wash the showcase by water to prevent from short circuit and creepage accident.
- (5) Please cut off power socket when repairing or replacing light.

4. Operation attention

- (1) Please put the showcase lightly when moving and gradient isn't more than 45° .
- (2) Please put it in ventilated and dry place and be away from heat source and dust to prevent from affecting cooling effect.
- (3) If the socket don't have grounding device, please make the hull ground to prevent from creepage accident.
- (4) The power capacity shouldn't be less than 200V, please check circuitry and capacity before operation. If the power isn't coherent with power requirement, please add manostat whose capacity is more than 1000W before reusing.
- (5) The thermostat has been adjusted to best place before out of factory. You shouldn't adjust it.
- (6) The time between turn off and turn on again can't be less than 3 minutes.
- (7) Please don't put too much or overhot food.
- (8) Please assure the inner and surface of showcase is clean.
- (9) It has water plate, you should get rid of the water in the plate periodically.

5. Maintenance

- (1) If found special situation, please don't dismantle parts and should invite professional technician.
- (2) The time between turn off and turn on again should be more than 3 minutes.
- (3) Please get rid of dust and oil pollution periodically to improve cooling effect.
- (4) If you stop operating the showcase for a long time, you should cut off power, make it clean and put it in dry and ventilated place. Please check the electrical wire strictly by technician before operation again.

6. Familiar trouble and salvation

Phenomena	Possible reason		Check content	Solvation	
Indicator doesn't work	Compressor doesn't work	Power has no electric	Check by multimeter	Connect power	
		Socket is loose	examine	Tight socket	
		Thermostat foot is loose	Check by multimeter	Jointing or tighten it	
		Relay foot is loose	Check dismantled cover	Tighten it	
	Compressor is working	Indicator doesn't work	Dismantle indicator	Replace indicator	
		Indicator foot is loose	examine	Tighten foot	
Compressor is working	Evaporator wing is blocked by ice	Cooling fan doesn't work	Check by multimeter	Replace fan	
		Temperature is too low	examine	adjust	
	Inner temperature is too high	Opening door too often			Opening door as few as possible
		Stock is too large			Take out some food
		Environment temperature is too high		Test by temperature meter	Improve environment temperature
		Cooling fan doesn't work	Cooling fan is bad	Check by temperature	Replace fan
			Foot is loose	examine	Tighten foot
		Inner temperature has been achieved	Thermostat is bad		Check thermostat
High noise	Showcase isn't put flat		examine	Make flat	
	Fan/compressor foot is loose		examine	Tighten screw	

7. Guarantee

We are responsible for maintenance for 1 year in the case of operation according to the user's manual. If the spare parts is bad caused by our bad quality, we are responsible for replace and repairing (expect glass)

You should pay rational fee after repairing the trouble caused by reasons as follows:

- (1)The trouble caused by disobeying requirements on user's manual.
- (2)The trouble caused by using spare parts by yourself.
- (3)The trouble caused by bad capacity fluctuate value or other natural factor.

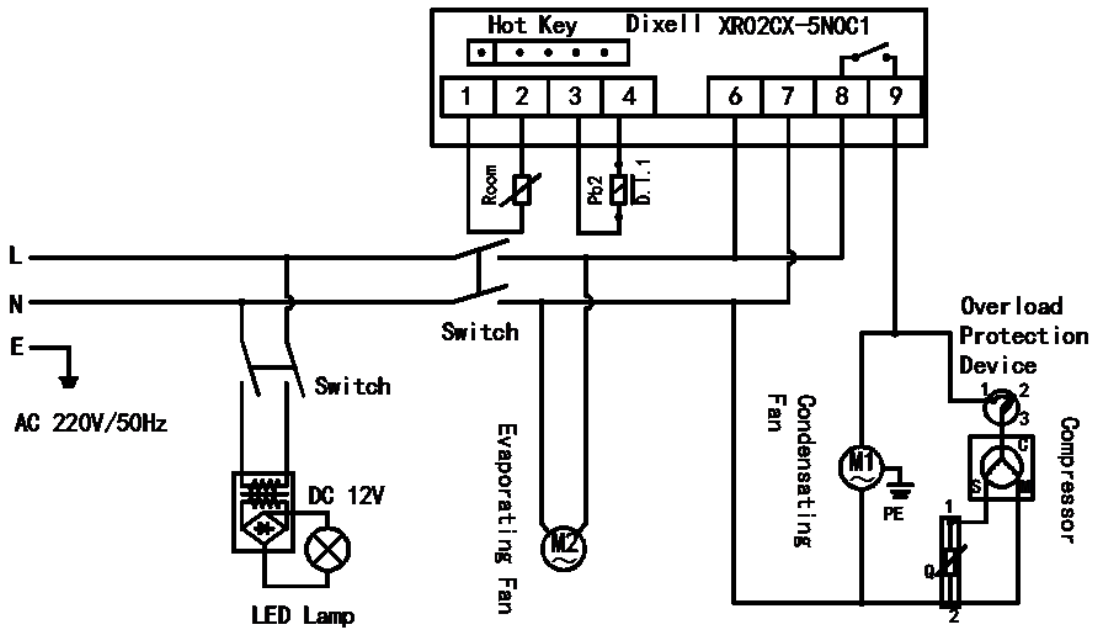

⚠ WARNING!

It's forbidden to tear down the machine or replace the component and refrigeration units by nonprofessional.