

KTVF450
TECHNISCHES HANDBUCH
TECHNICAL MANUAL

INHALTSVERZEICHNIS / INDEX :

- 1. MERKMALE / CHARACTERISTICS**
- 2. INNEN- UND AUSSENMAßE/ INSIDE , OUTSIDE DIMENSIONS**
- 3. EXPLOSIONSZEICHUNG / EXPLODED VIEW**
- 4. ERSATZTEILLISTE/ SPARE PART LIST**
- 5. SCHALTPLAN / WIRING DIAGRAM**

KTVF450



BESONDERE MERKMALE / CHARACTERISTIC SPECIALITIES

Klimaklasse / Climate class	:N
Sicherheitsklasse / Safety class	:1
Betriebstemperatur / Working temperature °C	:-2 / +10 °C
Thermostat-Solltemperatur / Thermostat set temperature	:+0 °C
Umgebungstemperatur / Ambient temperature	:+30 °C
Luftfeuchtigkeit / Humidity	:%40
Energieverbrauch / Energy consumption	:0,35 KW/h
Leistung / Power	:0,45 KW
Spannung - Frequenz / Voltage - Frequency	:220-240V / 50 Hz

ZUBEHÖR UND STEUERSCHALTER/ ACCESORIES AND CONTROL SWITCHES

Digitales Thermometer / Digital thermometer	: 2 Sonden (Digital) / 2 Probes (Digital)
Power-Lampe / Power lamp	:Stk. / Pcs. 2
Netzschalter / Power switch	:Stk. / Pcs. 1
Scharniergruppe / Hinge group	:Stk. / Pcs. 4
Fuß / Feet	:Stk. / Pcs. 6

TECHNISCHE DATEN/ TECHNICAL CHARACTERISTICS

Außenmaße / Outside dimensions	:1210x790x1300mm
Innenmaße / Inside dimensions	:1115x690x750mm
Verpackungsmaße / Packing dimensions	:1400*950*1400mm
Bruttogewicht / Gross weight	:300 kg
Nettogewicht / Net Weight	:310 kg
Außengehäuse / External housing	:0,50 mm INOX 430 +PVC
Innengehäuse / Internal housing	:0,50 mm INOX 430 +PVC
Kompressor / Compressor	:NEU 2168 U - R290 - 50 Hz
Kondensator / Condenser	:Ohne Lüfter/ Without fan
Kondensator-Lüfter / Condenser fan	:10W
Verdampfer / Evaporator	:VTN120
Verdampfer-Lüfter / Evaporator fan	:10W
Trockner / Dryer	:30 gr 15002SGDR02
Kältemittel /Refrigerant	:R290
Kältemittelmenge/ Refrigerant amount	:120 gram
Zertifizierungen / Certifications	:TS 2225 EN 30335-2-4
Seriennummer / Serial No	: Auf der Verpackung / On the packaging
Verpackung / Package	: Holzpalette , Verpackt in Karton und Nylon Wooden pallet , Packed in carton and nylon

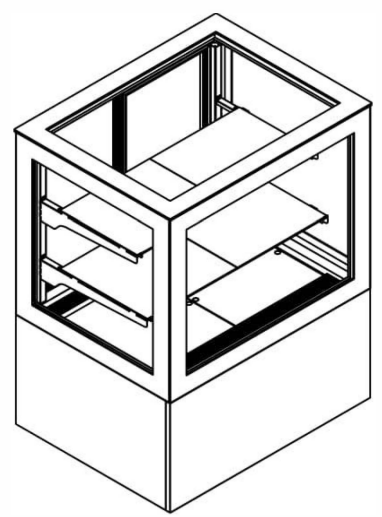
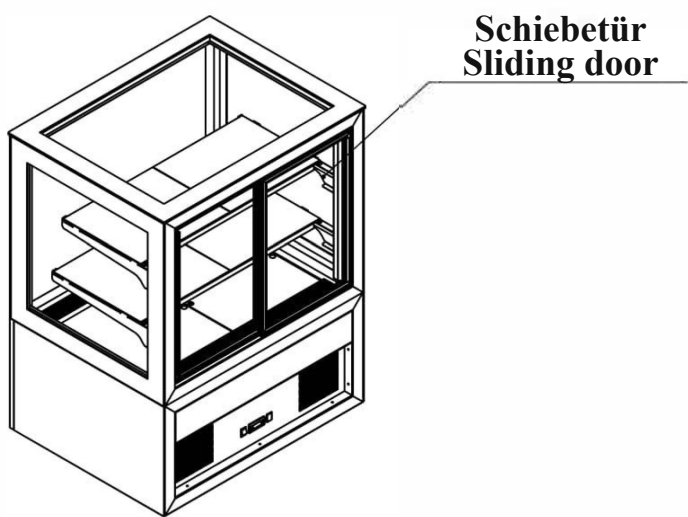
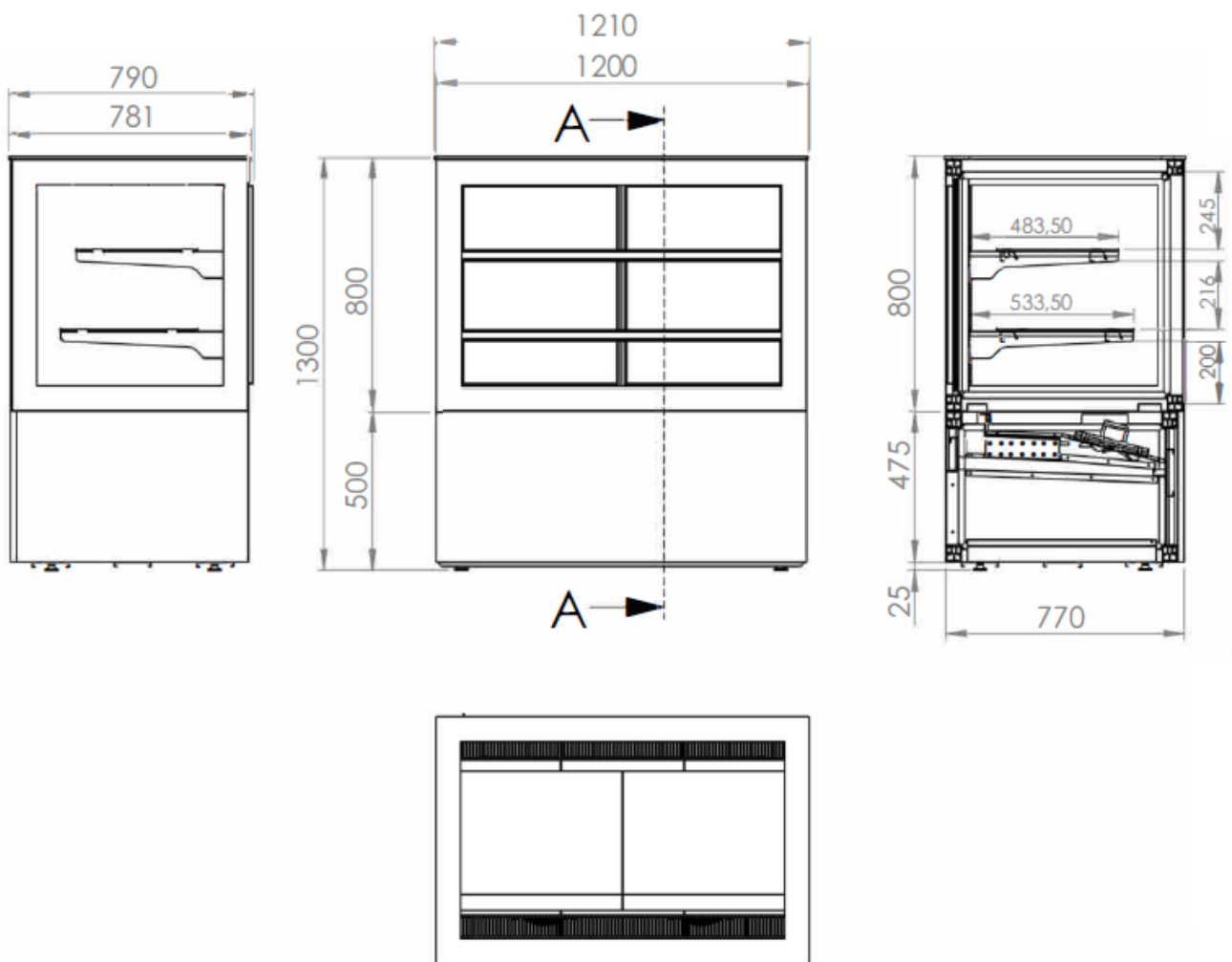

AUSSENMAßE/ OUTSIDE DIMENSIONS : 1210X790X1300
INNENMAßE/ INSIDE DIMENSIONS: 1115X690X750

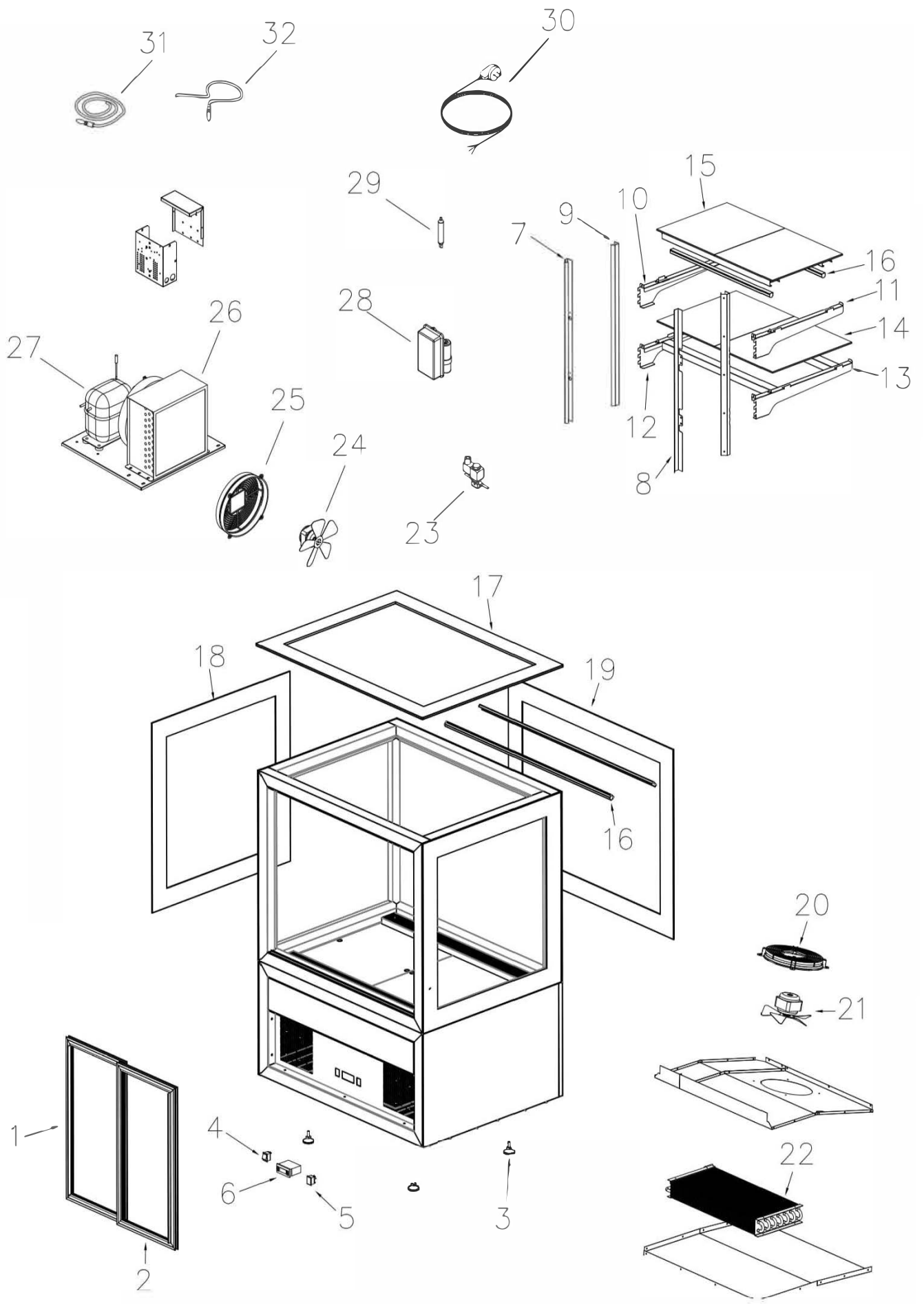

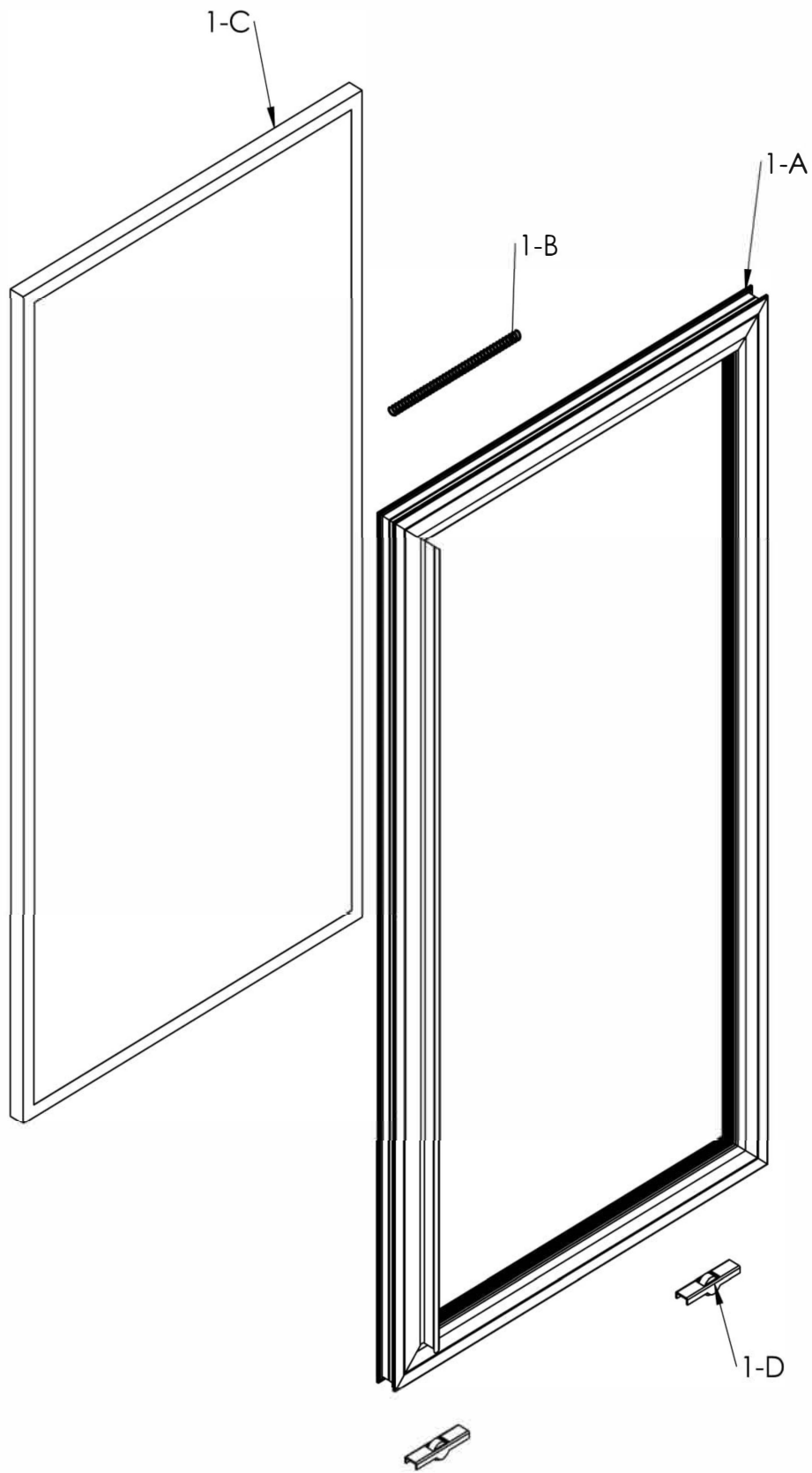

KTVF450 ERSATZTEILLISTE / KTVF450 SPARE PART LIST

NR.	CODE	BEZEICHNUNG	DESCRIPTION	ANZAHL QUANTITY
1		SCHIEBETÜR (LINKS)	SLIDING DOOR (LEFT)	1
1-A		TÜRDICHTUNG	DOOR GASKET	1
1-B		SPRING	FEDER	1
1-C	B00CA513	GLAS (SCHIEBETÜR)	GLASS (SLIDING DOOR)	1
1-D	B00AY103	RAD	WHEEL	2
2		SCHIEBETÜR (RECHTS)	SLIDING DOOR (RIGHT)	1
3	B00AY103	FUSS	FEET	6
4	B00DU102	EIN / AUS SCHALTER	ON - OFF SWITCH	1
5	B00DU101	NETZSCHALTER	POWER SWITCH	1
6	A00DJ100-Dİ	DIGITALER THERMOSTAT (DİXELL)	DIGITAL THERMOSTAT (DİXELL)	1
7		STANGE (LINKS)	ROD (LEFT)	1
8		STANGE (RECHTS)	ROD (RIGHT)	1
9		DECKEL	COVER	2
10		REGALSCHIENE	RACK RAIL	1
11		REGALSCHIENE	RACK RAIL	1
12		REGALSCHIENE	RACK RAIL	1
13		REGALSCHIENE	RACK RAIL	1
14	B00CA508	GLASABLAGE	GLASS SHELF	2
15	B00CA507	GLASABLAGE	GLASS SHELF	2
16	B00LA343	LED	LED	5
17	B00CA498	OBERES GLAS (SCHWARZ)	UPPER GLASS (BLACK)	1
17	B00CA530	OBERES GLAS (WEISS)	UPPER GLASS (WHITE)	1
18	B00CA467	SEITENGLAS (SCHWARZ)	SIDE GLASS (BLACK)	2
18	B00CA468	SEITENGLAS (WEISS)	SIDE GLASS (WHITE)	2
19	B00CA497	RÜCKGLAS (SCHWARZ)	REAR GLASS (BLACK)	1
19	B00CA531	RÜCKGLAS (WEISS)	REAR GLASS (WHITE)	1
20	A00EP100	LÜFTERABDECKUNG	FAN COVER	1
21	A00FA109	10W ELCO LÜFTER	10W ELCO FAN	1
22	A00EV222	VERDAMPFER VTN120	EVAPORATOR VTN120	1
23	A00SL100	MAGNETVENTIL 1/4	SOLENOID VALVE 1/4	1
24	A00FA109	10W ELCO LÜFTER	10W ELCO FAN	1
25	A00EP101	LÜFTERABDECKUNG	FAN COVER	1
26	A00KN113	KONDENSATOR OHNE LÜFTER	CONDENSER WITHOUT FAN	1
27	A00K0202	KOMPRESSOR NEU 2168 U - R290 - 50 Hz	KOMPRESSOR NEU 2168 U - R290 - 50 Hz	1
28	A00K0202-A	RELAIS-BOX	RELAY BOX	1
29	A00DR100	TROCKNER	DRYER	4
30	B00FK100	NETZKABEL	PLUG CABLE	1
31	A00DJ109	SONDE	PROBE	1
32	A00DJ102	SONDE	PROBE	1

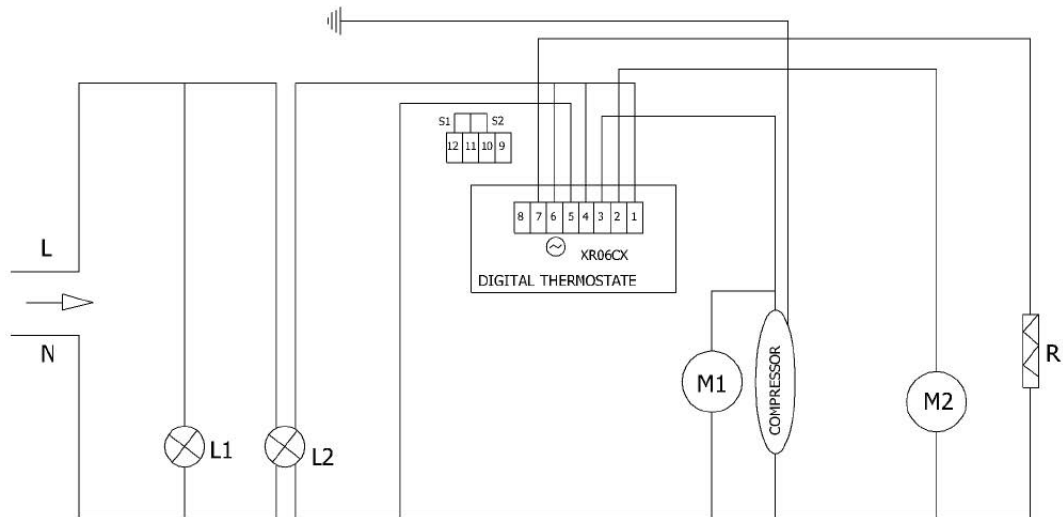

DIGITALER THERMOSTAT/ DIGITAL THERMOSTAT

M1 : LÜFTERMOTOR (KONDENSATOR) / FAN MOTOR (CONDENSER)

M2 : LÜFTERMOTOR (VERDAMPFER) / FAN MOTOR (VERDAMPFER)

S1 : SONDE / PROBE

S2 : SONDE / PROBE

L1 : POWER-LAMPE/ POWER LAMP

L2 : EIN / AUS LAMPE / ON OFF LIGHT

R: VERDAMPFUNGSWIDERSTAND / EVAPORATE RESISTANCE

