

**KTVF600**  
**TECHNISCHES HANDBUCH**  
**TECHNICAL MANUAL**

**INHALTSVERZEICHNIS / INDEX :**

- 1. MERKMALE / CHARACTERISTICS**
- 2. INNEN- UND AUSSENMAßE/ INSIDE , OUTSIDE DIMENSIONS**
- 3. EXPLOSIONSZEICHUNG / EXPLODED VIEW**
- 4. ERSATZTEILLISTE/ SPARE PART LIST**
- 5. SCHALTPLAN / WIRING DIAGRAM**

# KTVF600



## BESONDERE MERKMALE / CHARACTERISTIC SPECIALITIES

Klimaklasse / Climate class	:N
Sicherheitsklasse / Safety class	:1
Betriebstemperatur / Working temperature	:-2 / +10 °C
Thermostat-Solltemperatur / Thermostat set temperature	:+0 °C
Umgebungstemperatur / Ambient temperature	:+30 °C
Luftfeuchtigkeit / Humidity	:%40
Energieverbrauch / Energy consumption	:0,56 KW/h
Leistung / Power	:0,70 KW
Spannung - Frequenz / Voltage - Frequency	:220-240V / 50 Hz

## ZUBEHÖR UND STEUERSCHALTER/ ACCESORIES AND CONTROL SWITCHES

Digitales Thermometer / Digital thermometer	: 2 Sonden (Digital) / 2 Probes (Digital)
Power-Lampe / Power lamp	:Stk./Pcs. 3
Netzschalter / Power switch	:Stk./Pcs. 1
Scharniergruppe / Hinge group	:Stk./Pcs. 4
Fuß / Feet	:Stk./Pcs. 9

## TECHNISCHE DATEN/ TECHNICAL CHARACTERISTICS

Außenmaße / Outside dimensions	:1610x790x1300mm
Innenmaße / Inside dimensions	:1515x690x750mm
Verpackungsmaße / Packing dimensions	:1710*890*1500mm
Bruttogewicht / Gross weight	:395 kg
Nettogewicht / Net Weight	:385 kg
Außengehäuse / External housing	:0,50 mm INOX 430 +PVC
Innengehäuse / Internal housing	:0,50 mm INOX 430 +PVC
Kompressor / Compressor	:2x NEK 6181 U 50HZ - R290
Kondensator / Condenser	:2x (Ohne Lüfter/ Without fan)
Kondensator-Lüfter / Condenser fan	:10W
Verdampfer / Evaporator	:2x 600
Verdampfer-Lüfter / Evaporator fan	:10W
Trockner / Dryer	:30 gr 15002SGDR02
Kältemittel /Refrigerant	:R290
Kältemittelmenge/ Refrigerant amount	:100 gram + 100 gram
Zertifizierungen / Certifications	:TS 2225 EN 30335-2-4
Seriennummer / Serial No	: Auf der Verpackung / On the packaging
Verpackung / Package	: Holzpalette , Verpackt in Karton und Nylon Wooden pallet , Packed in carton and nylon

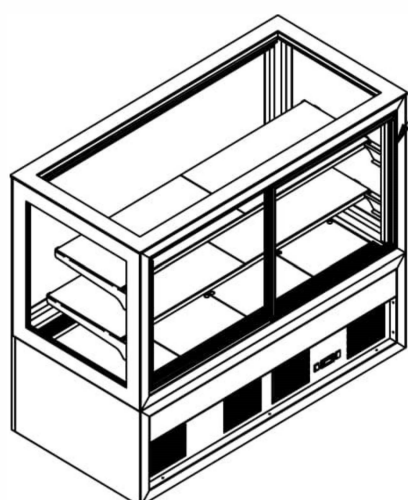
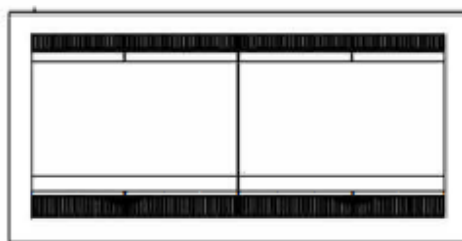
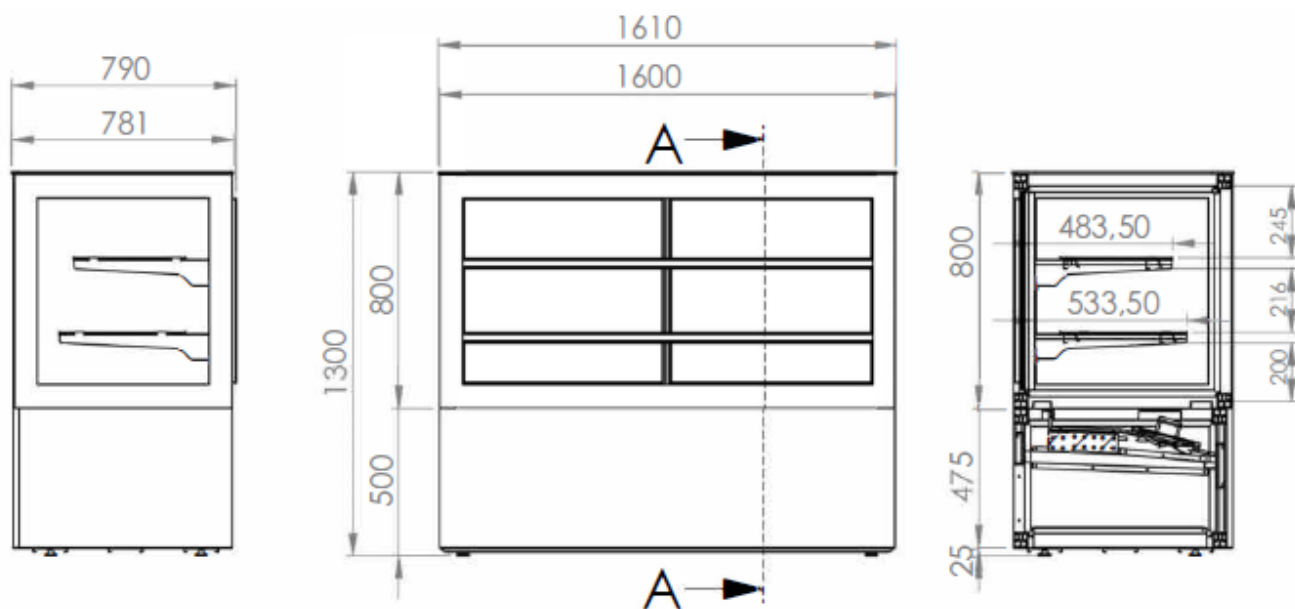

**Schiebetür**  
**Sliding door**

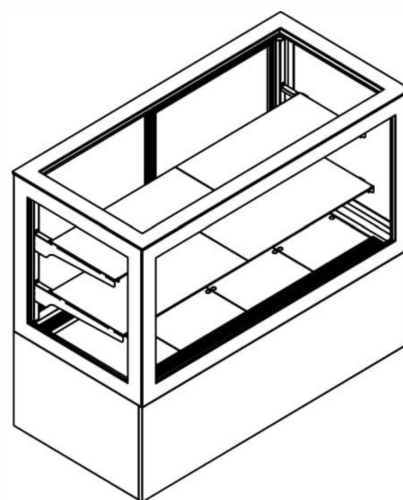

**AUSSENMAßE/ OUTSIDE DIMENSIONS : 1610X790X1300**

**INNENMAßE/ INSIDE DIMENSIONS: 1515X690X750**

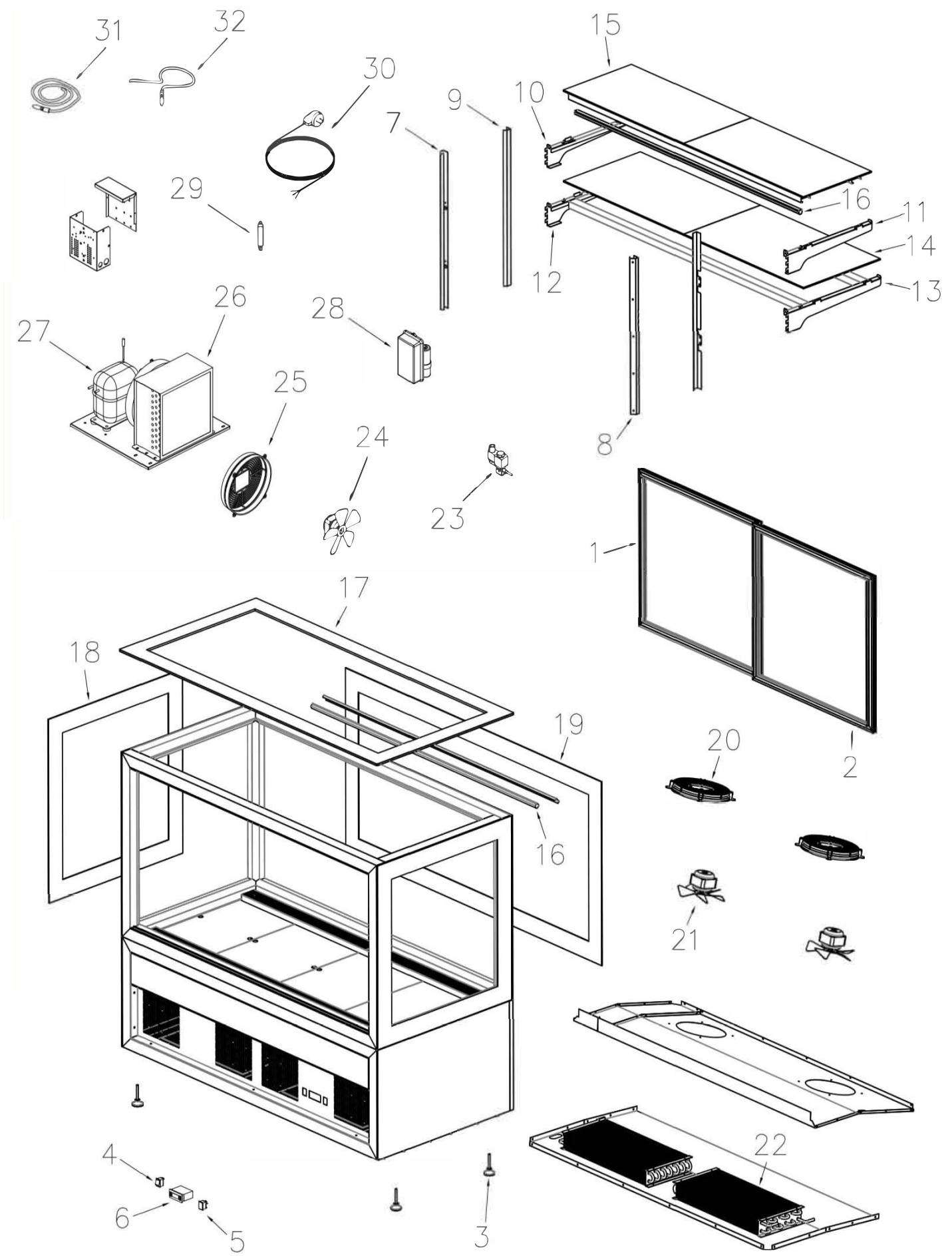

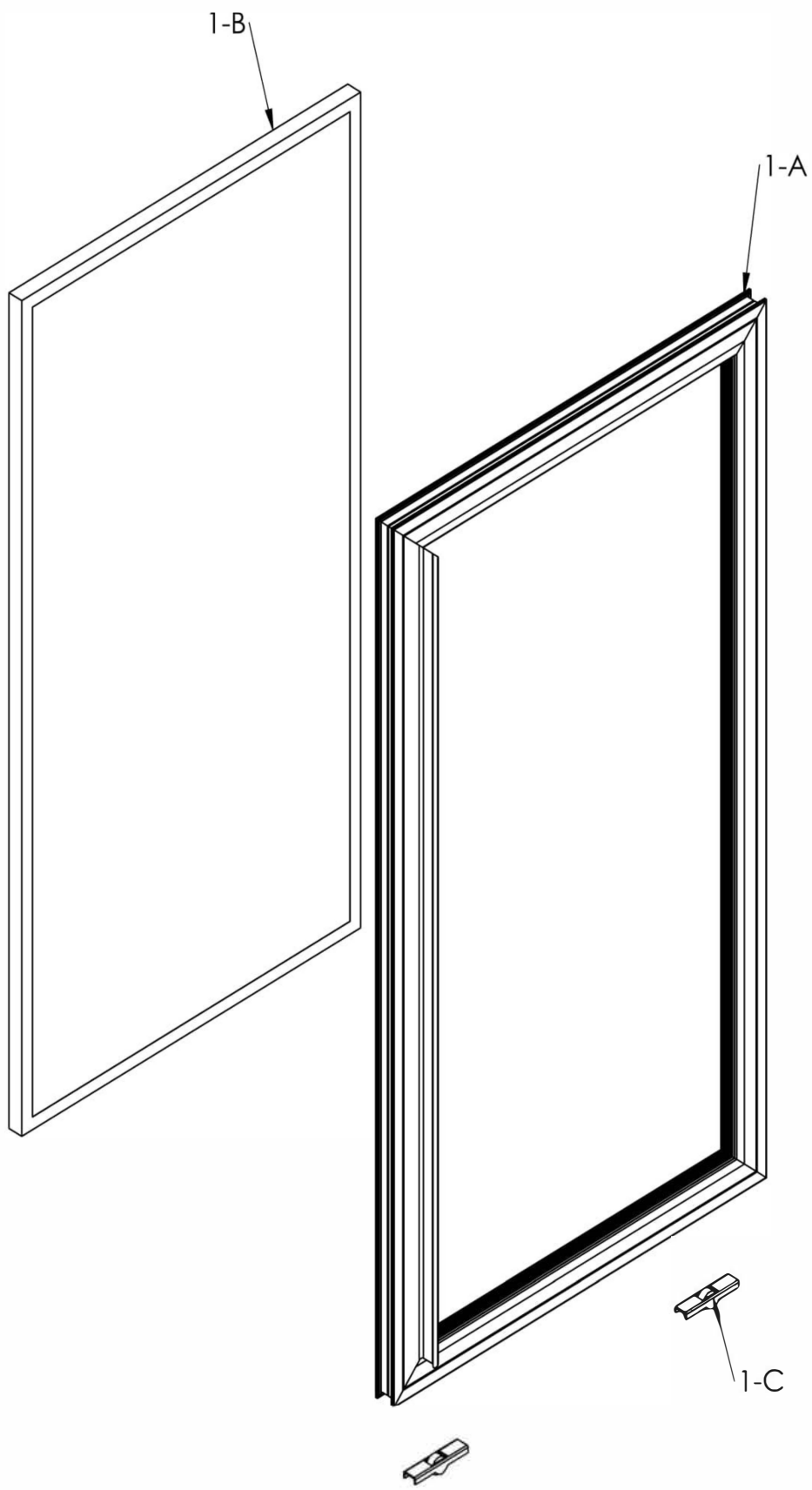

## KTVF600 ERSATZTEILLISTE / KTVF600 SPARE PART LIST

NR.	CODE	BEZEICHNUNG	DESCRIPTION	ANZAHL QUANTITY
1		SCHIEBETÜR (LINKS)	SLIDING DOOR (LEFT)	1
1-A		TÜRDICHTUNG	DOOR GASKET	1
1-B	B00CA515	GLAS (SCHIEBETÜR)	GLASS (SLIDING DOOR)	1
1-C	B00AY109	RAD	WHEEL	2
2		SCHIEBETÜR (RECHTS)	SLIDING DOOR (RIGHT)	1
3	B00AY114	FUSS	FEET	9
4	B00DU102	EIN / AUS SCHALTER	ON - OFF SWITCH	1
5	B00DU101	NETZSCHALTER	POWER SWITCH	1
6	A00DJ100	DIGITALER THERMOSTAT (DIXELL)	DIGITAL THERMOSTAT (DIXELL)	1
7		STANGE (LINKS)	ROD (LEFT)	1
8		STANGE (RECHTS)	ROD (RIGHT)	1
9		DECKEL	COVER	2
10		REGALSCHIENE	RACK RAIL	1
11		REGALSCHIENE	RACK RAIL	1
12		REGALSCHIENE	RACK RAIL	1
13		REGALSCHIENE	RACK RAIL	1
14	B00CA510	GLASABLAGE	GLASS SHELF	2
15	B00CA509	GLASABLAGE	GLASS SHELF	2
16		LED	LED	5
17	B00CA500	OBERES GLAS (SCHWARZ)	UPPER GLASS (BLACK)	1
17	B00CA532	OBERES GLAS (WEISS)	UPPER GLASS (WHITE)	1
18	B00CA467	SEITENGLAS (SCHWARZ)	SIDE GLASS (BLACK)	2
18	B00CA468	SEITENGLAS (WEISS)	SIDE GLASS (WHITE)	2
19	B00CA499	RÜCKGLAS (SCHWARZ)	REAR GLASS (BLACK)	1
19	B00CA533	RÜCKGLAS (WEISS)	REAR GLASS (WHITE)	1
20	A00EP100	LÜFTERABDECKUNG	FAN COVER	2
21	A00FA109	10W ELCO LÜFTER	10W ELCO FAN	2
22	A00EV217	VERDAMPFER 600	EVAPORATOR 600	2
23	A00SL101	MAGNETVENTIL 1/4	SOLENOID VALVE 1/4	2
24	A00FA109	10W ELCO LÜFTER	10W ELCO FAN	2
25	A00EP101	LÜFTERABDECKUNG	FAN COVER	2
26	A00KN216	KONDENSATOR OHNE LÜFTER	CONDENSER WITHOUT FAN	2
27	A00KO205	KOMPRESSOR NEK 6181 U 50HZ - R290	COMPRESSOR NEK 6181 U 50HZ - R290	2
28	A00KO205-A	RELAIS-BOX	RELAY BOX	2
29	A00DR100	TROCKNER	DRYER	4
30	B00FK100	NETZKABEL	PLUG CABLE	1
31	A00DJ109	SONDE	PROBE	1
32	A00DJ102	SONDE	PROBE	1

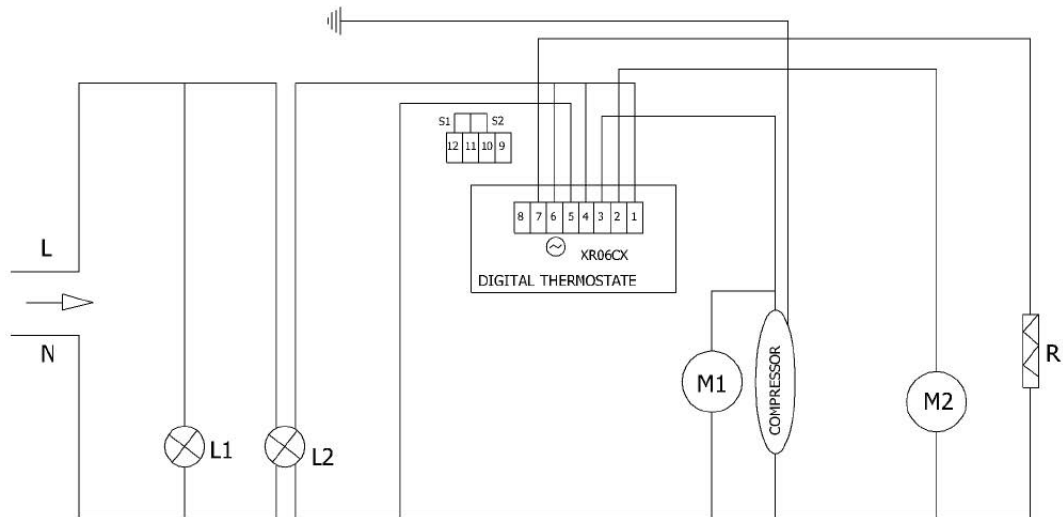

DIGITALER THERMOSTAT/ DIGITAL THERMOSTAT

M1 : LÜFTERMOTOR (KONDENSATOR) / FAN MOTOR (CONDENSER)

M2 : LÜFTERMOTOR (VERDAMPFER)/ FAN MOTOR (VERDAMPFER)

S1 : SONDE / PROBE

S2 : SONDE / PROBE

L1 : POWER-LAMPE/ POWER LAMP

L2 : EIN / AUS LAMPE / ON OFF LIGHT

R: VERDAMPFUNGSWIDERSTAND / EVAPORATE RESISTANCE

