

EXPLODED VIEW

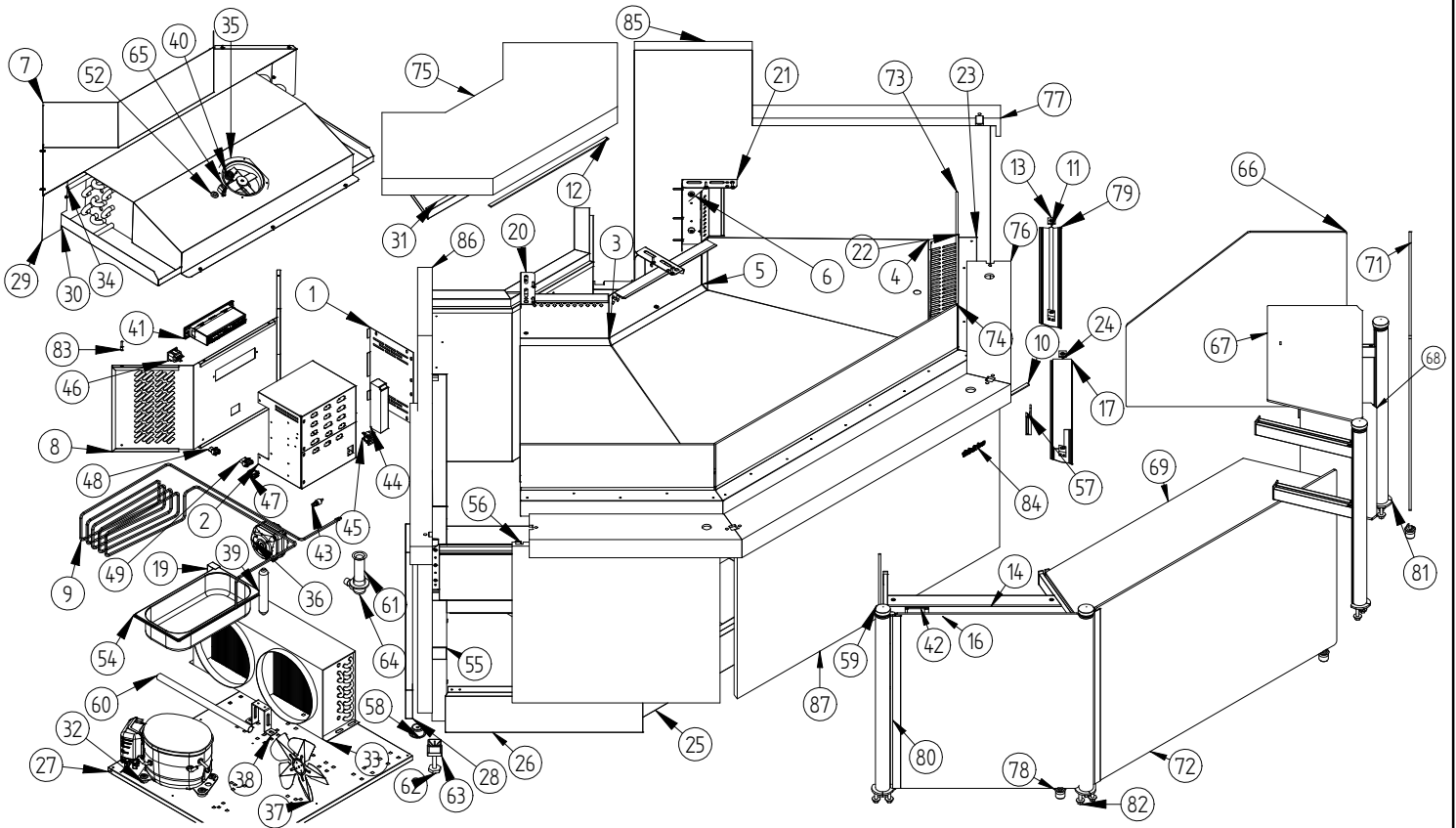

N°	Descripción	Cantidad	N°	Descripción	Cantidad	N°	Descripción	Cantidad
1	TAPA CAJ CONEXIONES MAGNUS	1	29	PROTECTOR EVAP MG AA90X850S/CR	1	59	PERFIL REF-1469 PLATA (6.2 MI)	2
2	CUERPO CAJA CONEXIONESMAGNUS	1	30	BANDEJA DESAGÜE EV. MG AA/AR90X850S/CR	1	60	TUBO DESAGUE TCOR-18/20 ref.4002583	1
3	BAND. EXP. IZQDA MG AA/AR90X850S/CR	1	31	CONTRA ENCIMERA IBIZA CENT AA/AR90X850S/CR	1	61	DESAGUE 3/4	1
4	BAND. EXP. DCHA MG AA/AR90X850S/CR	1	32	COMP. ASPERA NEK6213GK	1	62	PIE NIVELADOR 00301200516	6
5	BAND. EXP. CENT MG AA90 X850S/CR	1	33	CONDENSADOR 8X3 DOBLE	1	63	CONTERA REG. 40 x 40 M10	6
6	DUEL DEFL AIRE MAGNUS AA/AR90CX850CR	1	34	EVAP. MAGNUS VMG90AAR/ARR	1	64	CODO 90° ROSCADO MURAL GR PB	1
7	CIERRE TAPA EVAP. MG AA/AR90X850/CR	1	35	MOTOVENT. VITRINA HELADOS	1	65	SOPORTE BULBO	1
8	CUADRO MANDOS AA/AR90X850S/CR	1	36	MOTOVENT. 5W.IH-75 D-200I	2	66	COSTADO VIT. MAGNUS 2014 REFRIG.	2
9	TUB302X39MG12(1/4)	1	37	PALA 200 mm	2	67	ESTANTE SUP. LAT. VMG90/45AA	2
10	LED BLANCO FRIO 2175lm SC-ID-W (5m)	1	38	PIE MEDIANO (72 mm)	2	68	ESTANTE INF. LAT. VMG90/45AA	2
11	LED BLANCO FRIO 4350lm SC-ID-W2 (5m)	4	39	FILTRO 30 GR. 1/4X1/4 R-134a	1	69	ESTANTE SUP. CENTRAL VMG90AA	1
12	LED BLFRIO IP65 OP-TL1-300-CW-A (5m)	1	40	SONDA MICROPROC. NTC	1	70	ESTANTE INF. CENTRAL VMG90AA	1
13	ESCUADRAS FIJAC. PANTALLAS ILLUM	4	41	MICRO XW271L OAZUL M.FRONTAL INOX	1	71	FRONTAL MAGNUS LAT. VMG90/45AA	2
14	PERF. PANT. MAGNUS	1	42	X-REP DISPLAY AZUL	1	72	FRONTAL MAGNUS CENTRAL VMG90AA	1
15	PERF. PANT MAGNUS	1	43	VALVULA OBUS R134a 1/4 SOLDAR	1	73	TABICA LAT.CRISTAL VMG90AA	2
16	PERF. PROT. PANT. MAGNUS	1	44	FUENTE LED 12V 35W	1	74	TABICA CENT.CRISTAL VMG90AA	1
17	PERF.PROT.PANT. MAGNUS	1	45	CONECTOR MACHO E-5010	1	75	ENCIMERA TRABAJO MG AA90/AR90	1
18	PERF. PROT PANT. MAGNUS	1	46	CONECTOR HEMBRA E-5012	1	76	ENCIMERA FRONTAL VMGAA90R	1
19	SOPORTE LAT.BAND. DESAGÜE EML/EMS/SML	4	47	CAJA 1-0480698-0 2 VIAS M	5	77	BRAZO ENC. DCHO VMGX850R	1
20	SOP. ENCIM. IZQDD MAGNUS CR	1	48	CAJA 1-0480699-0 2 VIAS H	5	78	ENCLAVAMIENTO CRISTAL MAGNUS	3
21	SOP. ENCIM. DCHO MAGNUSCR	2	49	CAJA 1-0480701-0 3 VIAS H	2	79	PERF.PROT.PANT.MAGNUS	1
22	DUELA DEL. MGAA90X850CR	1	50	PLACA RESIT. 200 w THERMOST.	1	80	MONTANTE MAGNUS N°1 (F+A) 414.6501.005	1
23	POSTIZO APOYO DUELA DEL. MGAA90X850	1	51	RESISTENCIA CARTUCHO	1	81	MONTANTE MAGNUS N°2 (C+E) 414.6502.005	1
24	SOP. LUZ PANTLATERMGAA90	4	52	PASACABLE 9 mm	1	82	MONTANTE MAGNUS N°4 (D+B) 414.6504.005	2
25	CIERREFRONT INFERIORCENT MGAA90	1	53	BANDEJA G/N 1/3 x 65 mm	1	83	TUERCA REMACHAB. M4x6x11 S/CUE	4
26	CIERRE FRONT. INFERLAT.MGAA90	2	54	BANDEJA G/N 1/3 x 65 mm	1	84	MARCA INFRICO ECODOMES PLATA	1
27	BANCADA MG	1	55	RODAPIE VMGAA90X850R	1	85	COSTAMELADCHDx850	1
28	DCOR LAT INFERIORIZQDDMG850	2	56	HERRAJE KEKU MACHO REF.262.49.356	12	86	COSTAMELAIZQDDx850	1
			57	HERRAJE KEKU HEMBRA REF.262.51.380	12	87	DECOR FRONTAL MAGCENTRA	1
			58	BOLA RODAMIENTO 522-0-22	5			