

ggmgastro
INTERNATIONAL

Table Electric Bain Marie
User manual

Table Electric Bain Marie is designed by advantages of overseas products. They have features of new style, reasonable structure, easy to operate, good warmer result and saving energy, with features of easy operation, reasonable distribution and occupy less space. They are equipments for Chinese and Western food restaurant, Karaoke room and fast-food restaurant.

Model	Size (mm)	Voltage(V)	Power (W)	N.W.(KG)
ABMJ4	1245*350*370	230V	1500	12
ABMJ5	1512*350*370	230V	1800	14

A. Basic parameter

B. Attention for installation

1. The using voltage of the machine must be coordinated with the supplied.
2. User needed install suitable power switch and fuse near the machine.
3. There is grounding screw behind this oven, The grounding blot should be connected with more than 1.5 square mm copper with according to safety rules for safety sake.
4. Before using this product, Please check all parts and power supply and ground connection.

C. Instruction

1. Must need check the machine around to make sure exactly before using the equipment.
2. Shut on the power switch K1, the green indicator is on, at that time electricity reaches to the machine. Rotate the temperature controller clockwise to the point of the needed temperature, at that time the yellow indicator is on and the equipment begins to heat. When temperature reaches needed, the yellow indicator is off, the temperature stopped going up, and it lowers little the equipment get through electricity automatically then the yellow indicator is on, and the electric heating tube works again and the temperature goes up again, It repeats again and again to make sure temperature is constant in the setting range.
3. When user using it, the basins played in the machine, the best warmer result at that time.

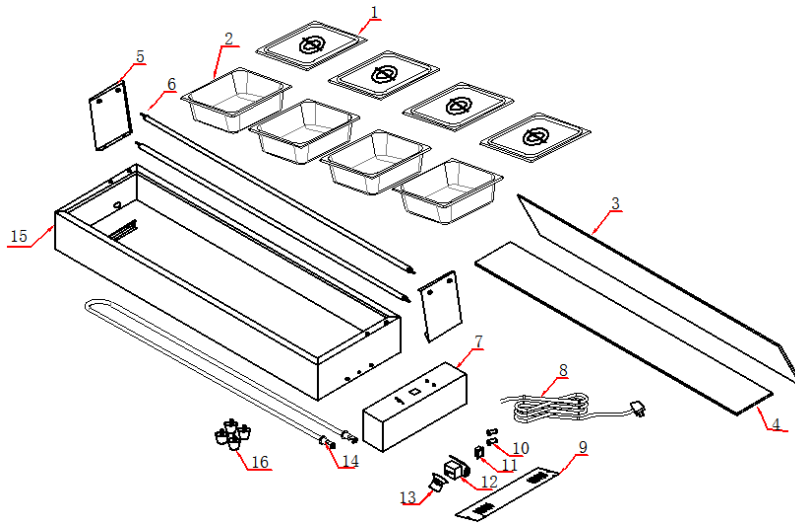

NO.	Spares
1	Lid
2	Gastronorm
3	Front window
4	Up window
5	Window fastener
6	Window holder
7	Electric box
8	Wire
9	Seal plate
10	Indicator light
11	Switch
12	Thermostat
13	Knob & gasket
14	Element
15	Pan
16	Foot

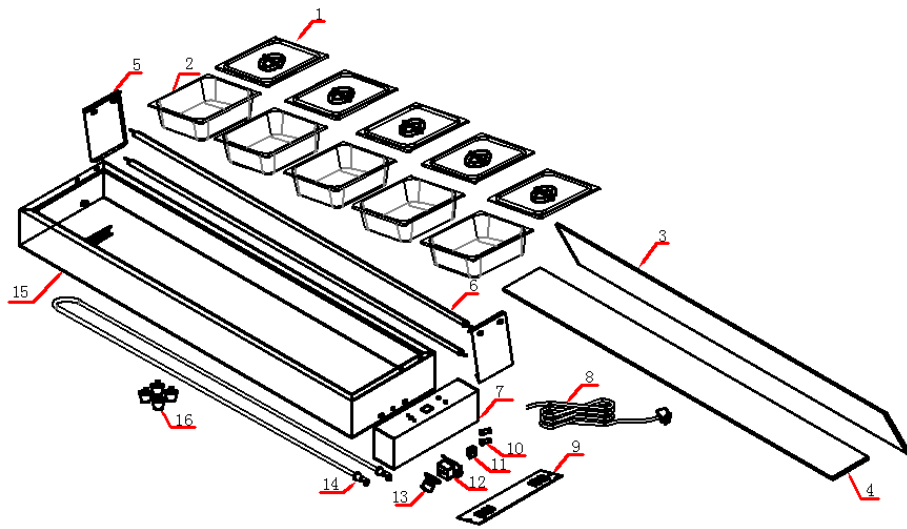

GGM Gastro International GmbH
Weinerpark 16, 48607 Ochtrup
www.gmgastro.com