

G、 PROBLEMS AND SOLUTIONS:

- Problem: Switching lights are off even though you turned them on.
- Cause: The power cord is not properly plugged into the outlet or the machine.
- Solutions: Turn off all button and make sure the power cord is firmly plugged. Into the outlet and machine. Turn on the switch again.
- Problem: The motor does not rotate/heat when the TURN switch is on.
- cause: The heating tube line is loose/burnt.
- Solutions: Firm the line/ change the heating tube.
- Problem: The heating temperature is too high or too low.
- Cause: The constant temperature implement is out of order.
- Solutions: Change the implement.

H、 Electrical schematic:

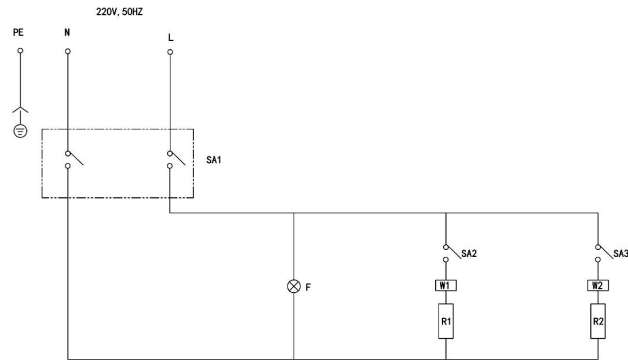

- SA1-Lighting indicator
- SA2-Popcorn heater and motor switch
- SA3-Heat preservation heater switch
- F-Flood light
- W-Popcorn machine temperature control
- R1-Popcorn machine heating element
- R2-Insulation heating pipe
- W2-Heat preservation tube temperature control

POPCORN MACHINE

User manual

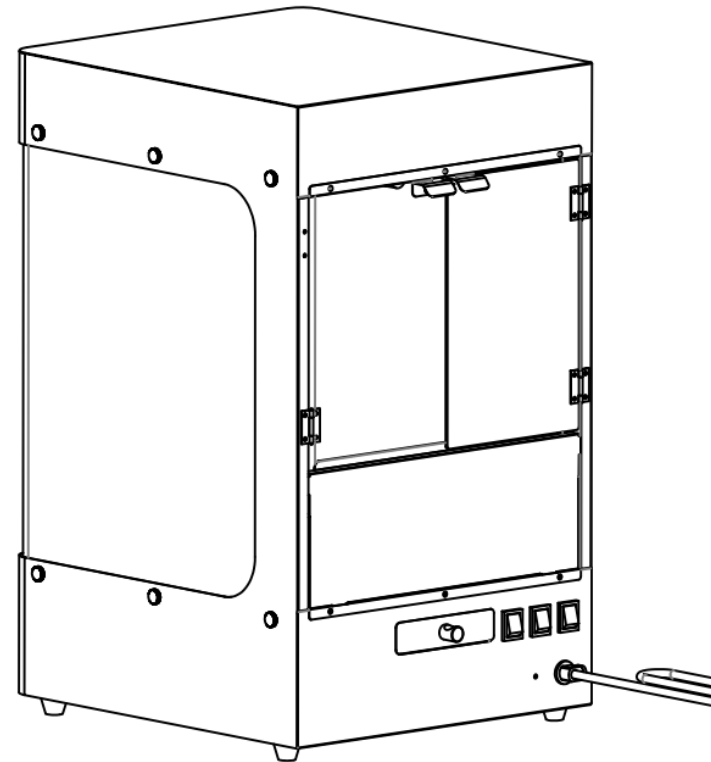

Model: PMHB55

A、 INTRODUCTION :

This is one of up-to-date food machine in the market. It is easy to clean, sanitation and convenient to operation and save resource. It is popular and becomes the best of all products in trattoria, snack and cinema.

▲ Please review this manual prior to and follow the cleaning instructions- Thank you!

B、 TRANSPORTAHON AND STORAGE:

Machine should be handled with care due to the glasses used. Cannot be converted and strongly shook. Should not be place at outdoor area. Should be put in storage which have good ventilation and have no causticity gas. If must be put in outdoor area, should prevent sun shine and raining.

C、 IMPORTANT SAFEGUARDS:

1. The machine should be put in stable and firm place which avoid direct shining and raining. Do not place on or near a hot gas or electric burner. Do not use outdoors.
2. Machine needs to be plugged into 1 10v dedicated circuit to operate properly. When using an electrical appliance, basic safety precautions should always be followed.
3. Always attach plug to appliance first, then plug cord in the wall outlet. To disconnect, turn any control of "off" then remove plug from wall outlet.
4. from outlet when not in use and before cleaning.

D、 SPECIFICAHON:

Model	Voltage (V)	Frequency (Hz)	Power (W)	Size(mm)
PMHB5S	220	50/60	1305W	470x423x720mm

E、 OPERATING IN STRUCTIONS:

1. Turn on the WARM and HEATING switches on the top of cabinet. Wait3~ 6 minutes for kettle to heat up.
2. When machine is ready, turn on the TURN to start the motor.
3. Add corn &oil (and seasoning salt if needed) to the kettle. DO NOT OVERFILL
4. Close the doors or the oil and popcorn will immediately spray out all over the sides of the machine.
5. When the popping ceases, turn off the TURN switch. Always have the kettle motor switch OFF when not popping corn.
6. Dump popped corn by releasing the kettle, rotating the black handle and pulling downward. Put the kettle back in place using black the handle to hook the kettle to the holding bolt.
7. If you are making several batches continuously, do not have to wait for machine to reheat. It will already be preheat.
8. In order to keep your popcorn warm, turn the WARM switch on.
9. Motor air intake and exhaust holes of the machine must be clear of any obstruction.

F. CLEANING AND MAINTENANCE:

- 1.Clean your popcorn machine after every use.
- 2.Make sure the machine is unplugged and the kettle has completely cooled.
- 3.Wipe all oil off the inside and outside of the kettle with a DRY clean soft cloth.
- 4.Do not use benzene, scrubbing brushes or chemical cleaners, as these will damage the machine.
- 5.NEVER immerse the base of machine in water or let water drip inside.

WARNING



- 1.Water must NEVER be put on the popping Kettle.
- 2.DO NOT touch inside parts when the machine is hot as it may cause serious injury.