



Warm cup machine

User manual



TWJ335

Thanks for your purchasing and using Warm cup machine. For making full use of function of this product and reducing unnecessary damage and injure. Please read this manual carefully before using this machine and keep it well for future reference.

Warning ! Any refitting and wrong installation, adjustment and maintenance can lead to property loss and causality. Please contact the supplier if user needs to adjust it and all these should be done by trained special professionals.

Warning ! For your safety sake, do not put or store any flammable liquid, gas or other objects around the product.

Warning ! The shell of this equipment must be grounded for Safety sake. Thanks for your cooperation!

Warm cup machine is designed and developed by the company with combination of the advantage of both foreign and domestic similar products and achieves advantages such as fashionable design, reasonable structure and convenient operation and maintenance and durability. The temperature of the warming cup machine is automatically controlled by the temperature limiter inside the machine without adjustment. Mainly used for a variety of cups to keep warm. it is the first choice for the food industry enterprises such as western food restaurants, fast food restaurants, hotels and supermarkets and etc.

1. Product features:

This product is designed by our company absorbing the advantages of similar foreign products. It has the characteristics of novel style, reasonable structure, convenient operation, fast heating speed, uniform temperature, and energy saving. It is suitable for hotels, shopping malls, supermarkets, and places with large passenger flow.

1.1 Chip warmer technical data sheet:

Name	Model	Voltage	Power	Temperature controller number	Temperature range	Product outer Dimension: mm	Net weight
Warm cup machine	TWJ335	220 ~ 240V	140W	2	30~85℃	320*340*550	9.7KG

2. Instructions:

- 2.1 Do not damage, excessively bend, stretch, or twist the power cord, and do not place heavy objects or clamp the power cord.
- 2.2 After use, the Switch according to the "0" position, and then pull out the plug from the socket to avoid leakage or insulation aging vibration.
- 2.3 This product should be installed in a dry, clean, well-ventilated location, and placed in a horizontal position.
- 2.4 In order to ensure safety, the product must be grounded and a leakage switch is installed to ensure personal safety, otherwise it must not be used.
- 2.5 Please unplug it and wait for the product to cool down before moving, checking or cleaning.
- 2.6 Do not insert or unplug the plug with wet hands to avoid electric shock.

3. Transport and storage:

During transportation, this product should be handled with care to prevent severe vibration. The packaged product should generally be placed in a well-ventilated place to avoid long-term open storage. It should be stored in a warehouse without corrosive gas. For temporary storage, rain-proof measures should be adopted. Do not invert or stack the product to prevent damage to the product.

4. Installation Precautions:

- 4.1 The power supply and voltage used by this equipment must be consistent with the power supply

voltage of the product power plate.

- 4.2 The user needs to install a sufficient amount of power switch or air switch or (fuse breaker and leakage protector, etc.) near the equipment, and no debris is allowed in front of the switch for easy operation.
- 4.3 There are grounding bolts at the back of this equipment, and no less than 2.5 copper core wires should be used to reliably connect to the grounding wire that meets safety regulations during installation.
- 4.4 The "Equipotential Connection Terminal" on the equipment shell can be used for repeated grounding of the equipment, and the on-site installer decides whether to connect or not.
- 4.5 The power connection must be made by an electrical professional. The protection of this machine against touching live parts is Class I, and a large-opening (contact distance of more than 3mm), all-pole disconnection leakage protection switch must be installed in the power supply line.
- 4.6 The "green/yellow two-color wire" in the power cord is a grounding wire, which must be reliably connected to a protective conductor that complies with the national electricity safety regulations.
- 4.7 ▲Warning: It is strictly forbidden to connect the ground wire to the water pipe, gas pipe, heating pipe and other pipes, otherwise it may cause a safety accident.
- 4.8 ▲Warning: Pay attention to the high temperature of the equipment and do not touch the equipment casually to prevent burns. You must wait until the temperature drops to dissipate heat before the equipment can be moved or cleaned.
- 4.9 ▲Warning: During installation, do not place appliances on certain surfaces close to walls, partitions, kitchen equipment and the like unless they are made of non-combustible materials or the surfaces are covered with non-combustible insulation materials, and pay attention to waterproof regulations.
- 4.10 ▲Warning: For people who have physical, sensory or intellectual defects, or lack of experience and knowledge (including children), this manual is not applicable.
- 4.11 "Equipotential Mark" -  "Instructions for use: scope of application: used in various equipment, indicating those terminals that make each part of the equipment or system reach the same potential after being connected to each other, which is not necessarily ground potential, such as local interconnection lines

5. Safety precautions and use environment and use requirements:

- 5.1 This product should be placed in a stable place, the left and right sides should be more than 10cm away from incombustible materials, and the back should be more than 20cm away from incombustible materials (such as brick walls).
- 5.2 This equipment must be safely grounded before use. Before starting the machine, check whether the wiring is loose, whether the voltage used is correct, and whether the safety ground connection is reliable. The shell of this machine must be grounded to ensure safety. Thank you for your cooperation!
- 5.3 Whether the electrical components of the product are firmly connected and whether the safety grounding is reliable.
- 5.4 If the power cord is damaged, in order to avoid danger, it must be replaced by professionals from the manufacturer, its maintenance department or similar departments.
- 5.5 The installation and maintenance of the electrical connection of this product should be performed by professionals with electrician operation certificates.
- 5.6 The power cord should be an oil-resistant sheathed cable, not lighter than ordinary neoprene or other equivalent synthetic rubber sheathed cord H05RN-F.
- 5.7 The equipment cannot be stored and used in the open air, and cannot be used in places where it is particularly humid or dripping with water.
- 5.8 The equipment must be fixed and placed before use to prevent the equipment from moving during use.
- 5.9 If the appliances are placed close to walls, partitions, kitchen equipment, decorations, etc., it is recommended that these equipment and facilities be made of non-combustible materials, otherwise they should be covered with suitable non-combustible insulation materials, and pay close attention to fire protection regulations.
- 5.10 should be operated by designated personnel, and be proficient in the use of machinery and equipment.
- 5.11 The machine should not be touched by customers when it is working to avoid burns.
- 5.12 Be cautious when moving the machine, look for faults carefully, and do not knock.

6. Operation method:

- 6.1 The Switch is located in the front of the machine to Control the power supply ,The temperature limiter is installed inside the machine to control the heating temperature of the electric heating tube to ensure the use temperature of the bore.
- 6.2 Place the dried cup upside down in the chamber of the machine,Turn on the power, press the switch to the on position, The light inside the switch lights up at the same time the temperature limiter automatically performs the heating program, the current has been supplied to the equipment, the heating tube starts to work, when the temperature rises to When the temperature is required, the temperature limiter can automatically cut off the power supply, and the heating tube stops working. When the temperature drops slightly, the temperature limitert can automatically turn on the power, the electric heating tube resumes heating, and the temperature rises. Repeat this cycle to ensure that the temperature range is constant.
- 6.3 If an abnormal phenomenon occurs during use, it must be stopped immediately, and the use can only be

continued after inspection and troubleshooting.

6.5 ▲Warning: After finishing work every day, all power supplies of the equipment must be cut off.

Don't forget to turn off the power.

6.6 ▲Warning: When the appliance with multiple power supplies fails to be repaired, ensure the safe maintenance operation process. All working power supplies must be cut off before the maintenance operation can be carried out.

7. Cleaning and maintenance:

7.1 During cleaning and maintenance, the power supply should be cut off to prevent accidents.

7.2 After working every day, use a wet towel that does not contain corrosive detergents to clean the surface of the body and the surface of the power lead. It is strictly forbidden to rinse with water to avoid damage to the electrical performance. Cause a leakage accident.

7.3 Note: Appliances must not be cleaned with water jets or immersed in water to prevent electrical leakage caused by splashing.

8. Product electrical schematic diagram:

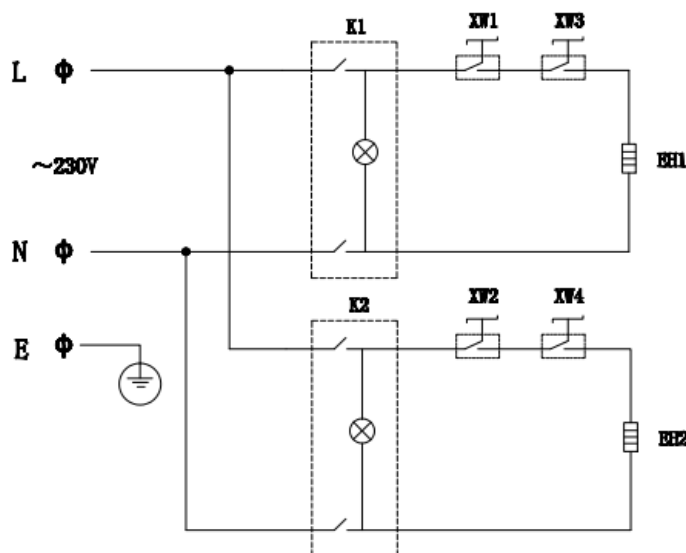

K1、K2—Switch

XW1、XW2、—temperature limiter(75℃)

XW3、XW4、—temperature limiter(90℃)

EH—Element

9. General troubleshooting methods:

Fault phenomenon	The reason	Elimination method
1、The switch is turned on, The light inside the switch doesn't work	1、 Damaged switch 2、 Wiring failure	1、 Replace the switch 2、 Check and repair wiring

2、 The inside of the switch lights up, but the temperature does not rise	1、 Temperature limiter failure(75℃) 2、 Loose wire 3、 Heating tube damage	1、 Replace temperature limiter 2、 Check and repair wiring 3、 Replace Heating tube
3、 The inside of the switch lights up, The temperature is too hot	(75 °C 90 °C)Temperature limiter failure	Replace temperature limiter

10. Product exploded drawing

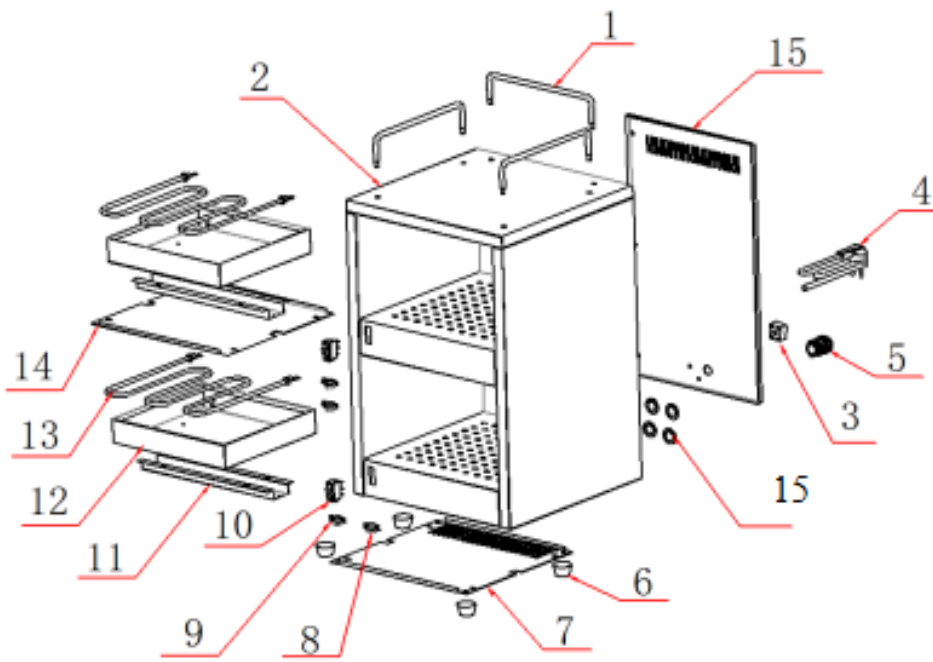

No.	Spare parts name
1	stents
2	Shell
3	Connect terminal
4	Wire
5	Wire clip
6	Foot
7	Bottom sealing board
8	Temperature limiter (75℃)
9	Temperature limiter (90℃)
9	Switch
10	Element bore fixer
11	Element bore
12	Element
13	Middle sealing board
14	Back sealing board
15	Protective coil

GGM Gastro International GmbH,

Weinerpark 16, 48607 Ochtrup

www.gmgastro.com